

SCALAR DAMAGE VARIABLE DETERMINED IN THE UNIAXIAL AND TRIAXIAL COMPRESSION CONDITIONS OF SANDSTONE SAMPLES

JERZY CIEŚLIK

Department of Geomechanics, Civil Engineering and Geotechnics,
AGH University of Science and Technology.

Abstract: The article is based on the results of uniaxial and triaxial compression tests, performed on Wustenzeller sandstone. An overview of the possible definitions of damage variable describing the process of damage development on the basis of various hypotheses has been presented in the first part of the article. In the main part of the article the author has presented the results of laboratory investigations, where the state of damage and its changes in rock samples under uniaxial and triaxial compression conditions were being observed. Using a modified procedure of triaxial tests, a definition of damage variable, determined on the basis of changes of volumetric stiffness of an examined rock, has been developed. Damage variable defined this way, in relation to a variable determined on the basis of axial stiffness changes, points to some anisotropy effects of damage phenomenon. The results obtained from both methods have been compared whereas the relations determining the evolution of damage variable in the loading process have been established.

1. ROCK DAMAGE – THE PHYSICAL SIDE OF THE PHENOMENON

Rock damage, understood as nucleation and development of defects leading to a complete damage of a sample, is strictly connected with primary, heterogeneous and discontinuous structure of a rock, observed in an appropriate scale. Observing the rock macroscopically, we are not able to notice any crucial features that would indicate the damage phenomenon, implying the mechanism of its damage. Observations of this type conducted microscopically let us determine the mineralogical content of a rock, the size of grains or crystals, the binding material, the arrangement of rock pores, crack geometry and its density, that is to say, the basic features which determine physical properties of a rock and mechanical properties of the samples obtained in macroscopic scale.

Looking from a micro perspective, a rock damage is a discrete and random phenomenon, identified physically as the development of micro cracks, which, arranging into groups, cause a macro crack or a certain zone of cracks (Moore and Lockner 1995, Wong 1982). Initial crack and fractures suitably oriented towards the loading, and the character of the loading, play a dominant role in this process.

In the case of compression of a rock sample, in the cracks and fractures oriented in accordance with the loading direction shear slips¹ occur, with result of tensile stress

¹ According to the so-called sliding crack model, used in micro mechanical analysis of rock, confirmed by microscopic observations (Paterson and Wong 2005, Rawling et al. 2002).

concentrations located at the tips. A propagation of the cracks in the form of the so-called wing cracks along the direction of the loading is the consequence of this state (Fig. 1) (Ashby and Sammis 1990, Horii and Nemat-Nasser 1985, Kemeny and Cook 1987). Cracks whose direction is perpendicular to the direction of the loading remain “deactivated” and do not take part in the process of damage growth.

In the triaxial compression, with a small confining pressure, the damage may take place just like in the case of uniaxial loading conditions. Nevertheless, for higher confining pressures, pre-existing cracks and pores become partially or completely closed. The applied stress induces the shear tractions on the cracks plane and frictional slips result in tensile stress concentrations at the two tips of the sliding cracks. This induces wing cracks of more substantial curvature and slightly deviated from the direction of the greatest loading. Due to the triaxial loading, the mechanism of interaction between the cracks is also different. As a consequence, the propagating cracks join each other, causing macroscopic shear (Horii and Nemat-Nasser 1985). The complex mechanism of micro cracks joining together, with buckling of micro columns, rotating and crushing the grains which results in macroscopic shear band has been confirmed by microscopic observations (Lockner et al. 1991, Moore and Lockner 1995, Paterson and Wong 2005, Wong 1982, Hallbauer et al. 1973) and macroscopically by shear band inclination to the direction of a higher loading. Depending on the confining pressure value, damaging the sample can occur either as one or several macro cracks or either one or several shear bands. The above description is applicable in the case of strong rocks with low porosity.

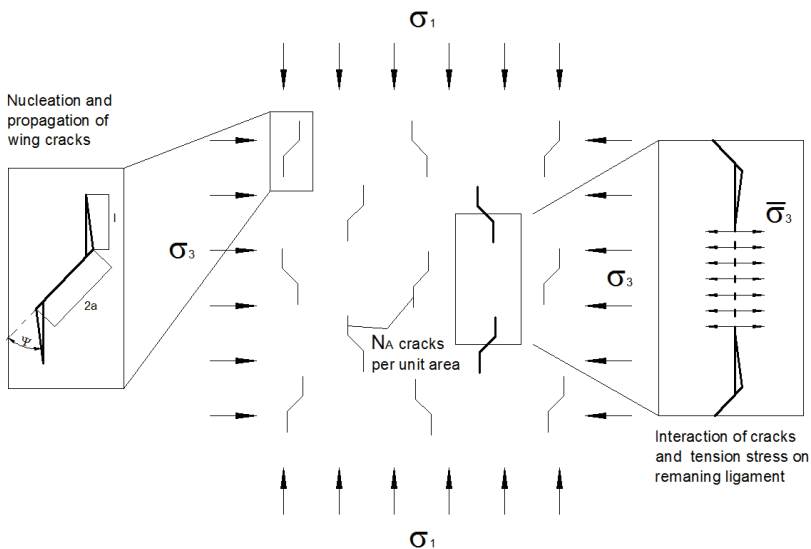

Fig. 1. Wing crack nucleation and propagation model, used in the micromechanical analysis of rocks (after Ashby and Sammis 1990)

In the case of weak rocks with high porosity, the damage can occur in the form of micro cracks around the initial pores, in the matrix, or in the binder and next, in the grains (according to a Hertz contact model), breaking the initial structure of the pores. In this case the development of cracks depends on the pores geometry and their arrangement. Such mechanism of damage occurrence, observed in weak limestones and sandstones that have high porosity, can be obtained even under hydrostatic compression (Vajdova et al. 2010, Bésuelle et al. 2003, Baud et al. 2000, El Bied et al. 2002).

2. POSSIBILITY OF THE DAMAGE DESCRIPTION (HYPOTHESES)

The damage and its development in the microscopic scale can be described by means of analysing the current arrangement, the shape, the size and the density of cracks, and taking into account their influence on each other. This type of description, built on the basis of the so-called micromechanical models let us link the behaviour of the rock in the macroscopic scale to the current state and the evolution of the microstructure (Krajcinovic 1996, Krajcinovic and Mastilovic 1995, Basista and Gross 1989, Dragon and Halm 1998, Gambrotta and Lagomersino 1993). Building this type of models the following information is required: the geometry and the orientation of the cracks obtained by means of microscopic analyses as well as the fracture mechanics parameters and the friction coefficient of the sliding cracks.

On the level of representative volume element (RVE) the damage can also be described by means of continuum damage mechanics (CDM). Using this approach one considers a certain volume of heterogeneous and discontinuous rock in micro scale, large enough though, so that one could assume that the stresses and strains within the volume are homogeneous. Homogenisation of micro cracks, fractures and pores in the representative volume element takes place thanks to the definition of inner state variables called damage variables (Skrzypek 2006, Lemaitre 1992, Krajcinovic 1996). Damage variables can be defined as scalar, vector or tensor quantities of various orders, depending on the evolution of the damage. On the basis of the equivalence principle, a concept of the so-called effective values of stress and strain is being introduced instead of stress and strain concepts, in the continuum damage mechanics. The damage variable describes the heterogeneous rock with micro defects in the form of cracks, fractures and pores with the theory of continuum mechanics.

2.1. SCALAR DAMAGE VARIABLE DEFINITION

Originally, the definition of the damage was introduced by Kachanov in 1958 as a continuity parameter $\psi = 1 - \omega$, describing the reduction of the bearing surface of a sample subjected to force (Fig. 2).

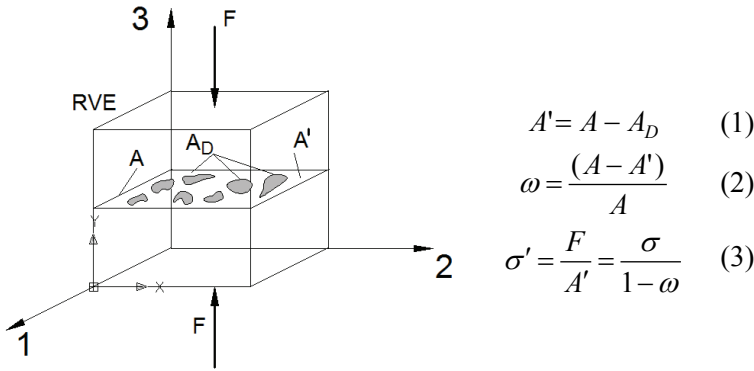

Fig. 2. Geometric damage variable proposed by Kachanov (after Skrzypek 2006)

As a result of the damage, the actual (deformed) surface of the sample A diminishes in the size of cavities, whereas the stress value σ' on the undamaged part of the section area A' can be determined by equation (3), (σ is a Cauchy stress).

A different concept of the damage analysis was presented by Chaboche (Chaboche 1988), who introduced the concept of an effective stress $\tilde{\sigma}$. In this analysis, it is necessary to consider three configurations of the rock: the initial configuration A , the actual damaged configuration B , and the pseudo-undamaged configuration C , equivalent to the damaged configuration B (Fig. 3) (Skrzypek 2006) with strain, stress or energy equivalence principle.

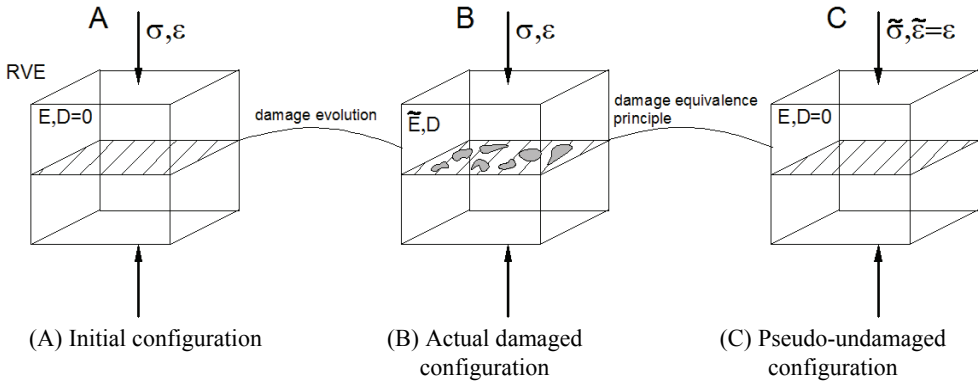

Fig. 3. Equivalence of configurations in the process of damage evolution (after Skrzypek 2006)

According to Chaboche's conception, effective stress $\tilde{\sigma}$ is one that would have to be applied to the element of the pseudo-damaged material, so that it could deform in the same way as the element of the damaged material $\tilde{\varepsilon} = \varepsilon$ exposed to stress σ . The

equivalence to the damaged configuration can be obtained based on the hypothesis of strain equivalence $\tilde{\varepsilon} = \varepsilon$, stress equivalence $\tilde{\sigma} = \sigma$, or elastic energy equivalence $\tilde{\Phi}^e = \Phi^e$ (Skrzypek 2006).

In the case of uniaxial compression of the rock samples, the damage evolution on a given loading level, can be observed on the basis of the changes of the axial stiffness of these samples, determining the actual value of the modulus of elasticity E_s (Cieřlik et al. 2011, Tomiczek 2008, Litewka et al. 1996). In this particular case, according to the strain equivalence principle, the following is obtained:

$$\tilde{\varepsilon}_e = \varepsilon_e \quad (4)$$

$$D_E = 1 - \frac{E_s}{E_{s \max}} \quad (5)$$

$$\tilde{\sigma} = \frac{\sigma}{(1 - D_E)} \quad (6)$$

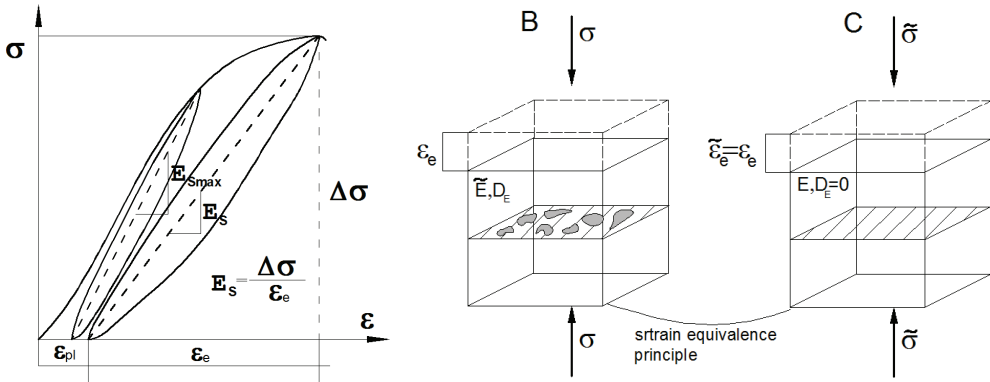
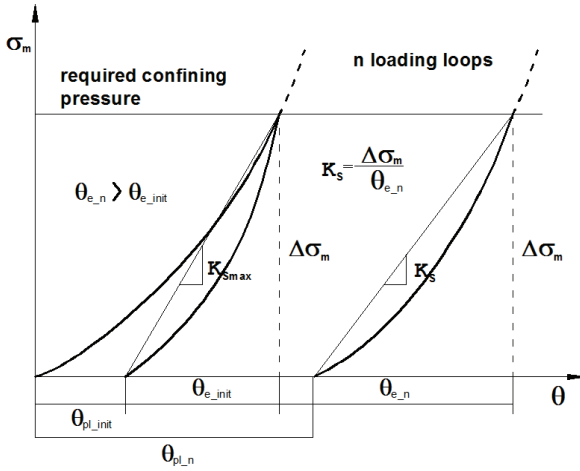

Fig. 4. Changes of the elasticity modulus E_s of the samples and the strain equivalence principle

The variable D_E is a scalar measure of the isotropic damage, i.e., the one which develops in the same way in each direction. Geometrically, this variable describes the damage development in the form of spherical cavities. It is usually determined in one cross section, perpendicular to the direction of the stress and it is assumed that the damage develops in the same way in the remaining directions.

On the basis of such an assumption, scalar variable can also be defined analysing the changes of volumetric stiffness of a rock sample, under the hydrostatic pressure compression p . The actual stiffness on a given level can be determined by means of Helmholtz volumetric modulus of elasticity K_s . In this case, according to the strain equivalence principle the following is obtained:



$\sigma_1, \sigma_2, \sigma_3$ – principal stress, $\varepsilon_1, \varepsilon_2, \varepsilon_3$ – principal strain

$$\tilde{\theta}_e = \theta_e \quad (7)$$

$$D_K = 1 - \frac{K_{s \max}}{K_s} \quad (8)$$

$$\tilde{\sigma}_m = \frac{\sigma_m}{(1 - D_K)} \quad (9)$$

$$\sigma_m = \frac{\sigma_1 + \sigma_2 + \sigma_3}{3} = p \quad (10)$$

$$\varepsilon_{e1} + \varepsilon_{e2} + \varepsilon_{e3} = \theta_e \quad (11)$$

$$\sigma_m = K\theta \quad (12)$$

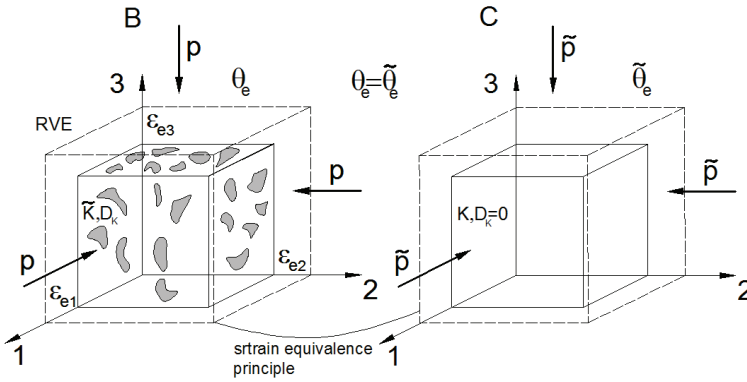

Fig. 5. Changes of the volumetric modulus of elasticity of the samples and the strain equivalence principle

As the measure of the damage used here is a scalar one, it does not describe the damage evolution anisotropy properly. Comparing, however, the variable quantity D_K achieved, as if, for the average damage in all the three directions, to variable D_E , that describes only damage in one direction, we are able to obtain information about whether the damage process occurs isotropically or anisotropically.

3. TESTING PROCEDURE FOR SANDSTONE SAMPLES

Testing Wustenzeller sandstone samples was conducted under the axisymmetrical stress state conditions. This type of loading can be achieved with the MTS triaxial cell, model 656.11 and a strength-testing machine with a stiff loading frame MTS 315.

The measurement of the axial force was carried out by means of a force transducer installed inside the pressure cell while the displacements were measured by extensometers. Radial displacements were determined through the measurement of changes of the sample circumference with a chain put around it, axial ones outside the cell, measuring the piston displacement. In order to determine damage variables there have been two separate testing procedures applied (Fig. 6).

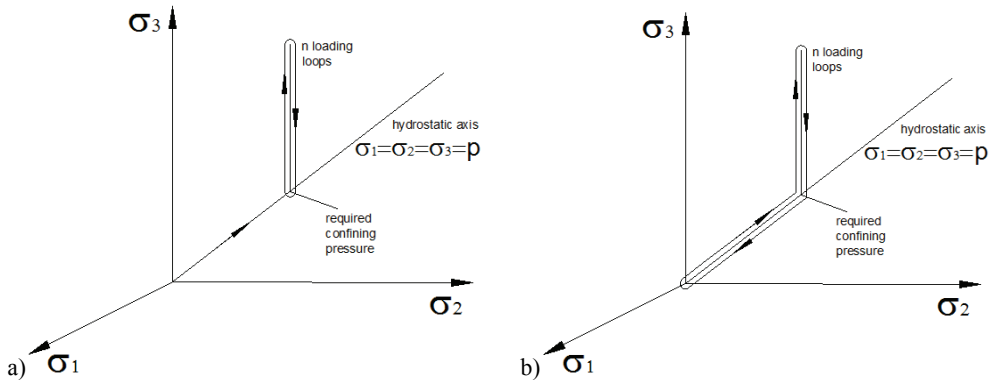

Fig. 6. Loading path of sandstone samples

For the damage variable determined on the basis of axial stiffness D_E after mounting the sample inside a triaxial cell and filling it with mineral oil, confining pressure was applied until the desired value (5, 10, 20, 40, 70 MPa). Next, the axial force impacting the piston of the cell was increased, finally it was reduced almost to zero on a given level of loading (usually 6–10 cycles)

For the damage variable determined on the basis of changes of volumetric stiffness D_K the procedure was similar. However, after each axial relief, the pressure in the triaxial cell was additionally reduced to zero

Twelve cylindrical sandstone samples were tested (size: $h = 70$, $d = 35$ mm), two samples for uniaxial loading and confining pressures 10, 20 and 40 MPa, three for 5 MPa pressure and one for 70 MPa pressure. The testing was conducted in the room temperature and humidity, and with the rate of axial strain in all the experiments of 1×10^{-4} [s $^{-1}$].

4. TEST RESULTS AND THEIR INTERPRETATION

Example characteristics, differential stress–strain and hydrostatic stress–volumetric strain for the sandstone tested are presented in Fig. 7

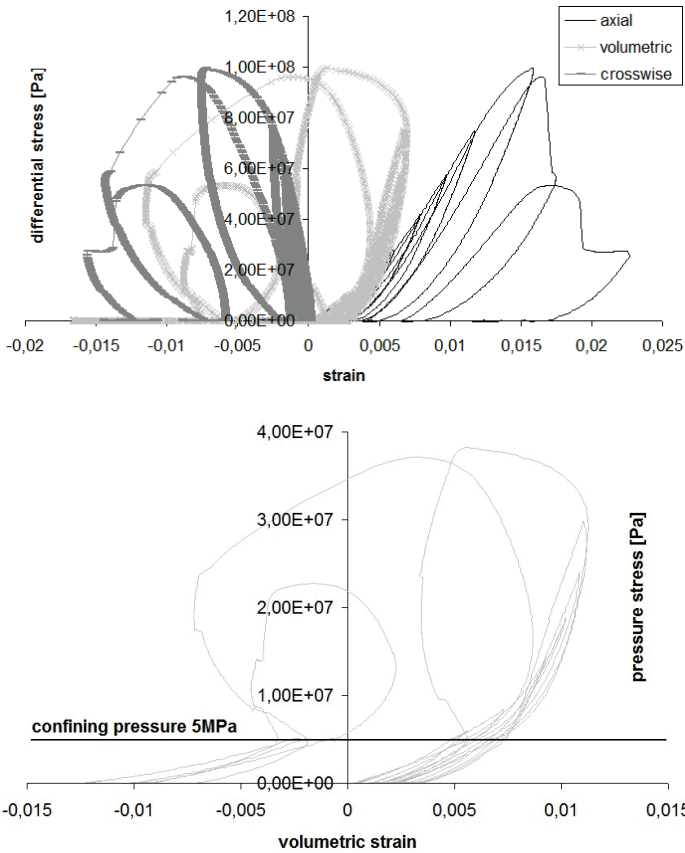

Fig. 7. Characteristics, differential stress–strain and hydrostatic stress–volumetric strain for confining pressure 5 MPa

The sandstone samples tested, in the whole range of confining pressures, demonstrate a brittle damage, which can be observed on sample characteristics and relatively small critical strain values (Cieślík et al. 2011). All the sandstone samples subjected to triaxial compression were damaged in the form of a single shear, whereas the ones compressed in the condition of uniaxial loading underwent axial splitting.

The values of a scalar damage variable D_E and D_K , determined on the basis of the changes of the axial and volumetric stiffness, are presented as a function of axial strain, normalized by critical strain $\varepsilon/\varepsilon_{crit}$ (Fig. 8) and axial irreversible strain (Fig. 9). This has let us trace the evolution of damage in the process of loading the samples. Because the process of damage is slight in higher confining pressures (Cieślík et al. 2011), scalar variables D_K , determined on the basis of changes of volumetric stiffness, were applied to four samples, two of them with the confining pressure 5 MPa and the other two for 10 MPa pressure and 20 MPa pressure, respectively.

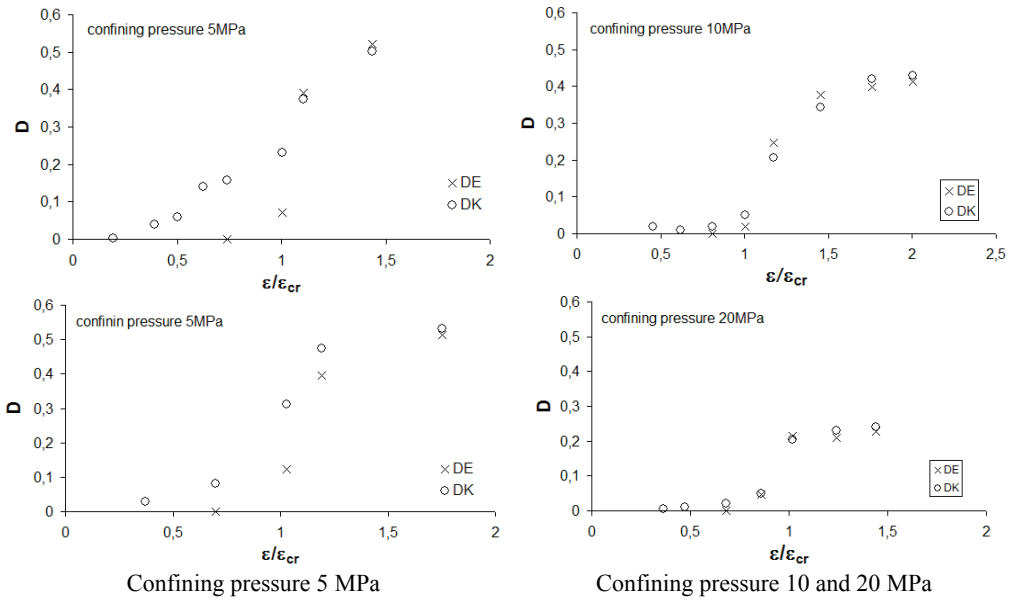

Fig. 8. Damage variables D_E and D_K , determined on the basis of the changes of axial and volumetric stiffness

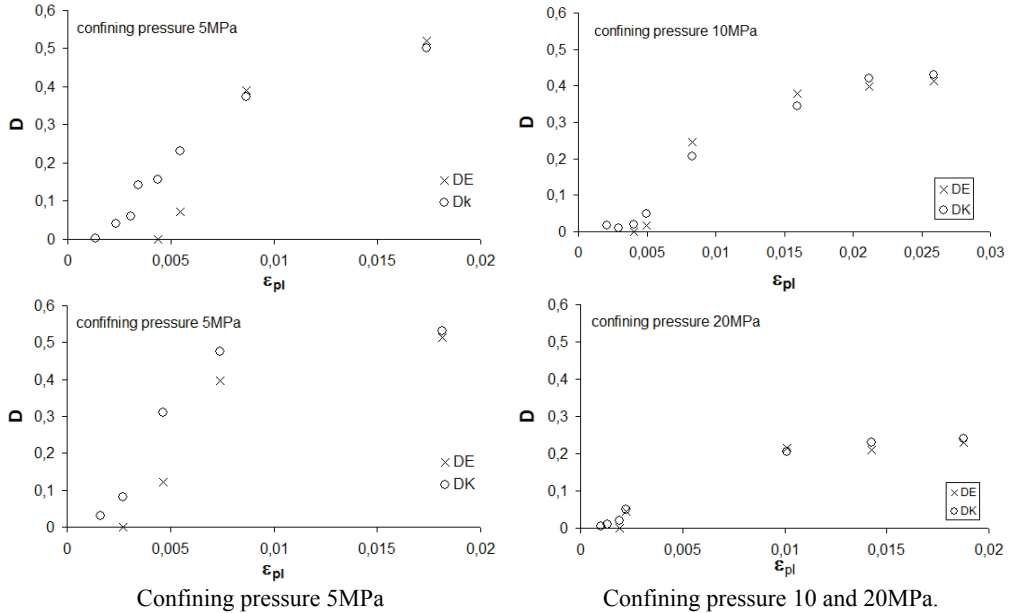

Fig. 9. Damage variables D_E and D_K determined on the basis of axial and volumetric stiffness reduction as a function of axial irreversible strain

In the case of all the three confining pressures, the damage process measured by a scalar damage variable D_K starts earlier than in the case of the variable determined on the basis of changes of axial stiffness D_E . It can be assumed that it roughly corresponds to the relative dilatancy threshold, after crossing it, the process of a stable cracks development starts. After crossing the critical deformations $\varepsilon/\varepsilon_{crit} = 1$ both descriptions coincide, give similar effects and their results are similar as well. In the case of 10 and 20 MPa confining pressure tests variables D_K and D_E determined by axial and volumetric stiffness reduction have quite similar value in the pre and post critical deformation range.

The relations of damage variable as a function of axial irreversible strain show the process of the damage evolution and irreversible strain that accompany it. One should notice that the damage, regardless of the description applied, appears only at a certain value of irreversible strain, which means that the process of plastic energy dissipation in the samples takes place before the damage occurs. This fact is critical to defining the damage plasticity constitutive model for rock.

For all confining pressure used in the tests, the final values (determined on residual stress level) of variables D_K and D_E are quite similar (Fig. 10). It should be emphasized that all these values are collected in the post critical deformation range where the shear failure of rock samples was observed.

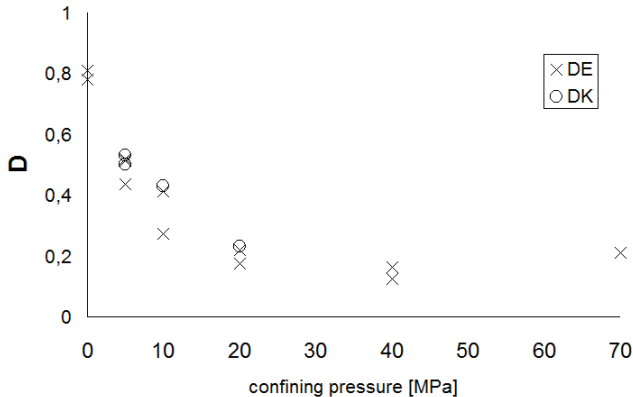

Fig. 10. Final values of damage variables D_E and D_K determined on residual stress level for all sandstone samples and all confining pressures

5. SUMMARY AND CONCLUSIONS

The results of laboratory tests performed in order to determine the character and intensity of the damage evolution in sandstone samples subjected to uniaxial and tri-axial compression have been presented in the article. Two scalar variables, determined

on the basis of reduction of axial and volumetric stiffness of the samples, have been used to describe the damage. The differences in the damage description, depending on the measurement applied as well as the damage variable, result from the following:

– In the pre-critical deformation range, the damage variable D_K , determined on the basis of changes of the axial stiffness E_s , highly depends on the primary porosity and closing the pores, which is visible, especially at higher confining pressures (Cieřlik et al. 2011). As a matter of fact, this variable describes the process of damage development only from macro dilatancy threshold, which once crossed leads to unstable increase in the cracks.

– It seems that the relevant differences in values of the variables D_K and D_E , achieved in pre-critical deformation range, are caused by the anisotropic character of the damage that appears since the moment of shear fault formation. The results of microscopic tests conducted by Moore and Lockner as well as Wong (Moore and Lonckner 1995, Wong 1992, Paterson and Wong 2005) confirm that the process of shear fault formation starts directly after crossing the critical deformation range. Since the moment of shear formation, the damage develops mainly in the shear band, and the damage evolution is isotropic (Skrzypek 2006). Also, in this situation, the results achieved for both damage variables are similar. The suggested damage variable D_K , determined on the basis of reduction of the volumetric stiffness of the samples in reference to the variable D_E which is determined on the basis of the changes of the axial stiffness, can provide important information concerning anisotropy of the process of damaging rock samples.

This study is sponsored through the statutory research funds of the AGH University of Science and Technology, Faculty of Mining and Geoengineering within the framework of the research program No. 11.11.100.277.

REFERENCES

- [1] ASHBY M.F., SAMMIS C.G., *The Damage Mechanics of Brittle Solids in Compression*, Pure Appl. Geophys., Vol. 133, Issue 3, 1990, 489–521.
- [2] BASISTA M., GROSS D., *A note on brittle damage description*, Mech. Res. Comm., 16, 1989, 147–154.
- [3] BAUD P., SCHUBNEL A., WONG T-F., *Dilatancy, compaction and failure mode in Solnhofen limestone*, J. Geophys. Res. Vol. 195, 2000, 19289–19303.
- [4] BÉSUELLE P., BAUD P., WONG T.-F., *Failure Mode and Spatial Distribution of Damage in Rothbach Sandstone in the Brittle-ductile Transition*, Pure Appl. Geophys., 160, 2003, 851–868.
- [5] CHABOCHE J.-L., *Continuum damage mechanics: Part I: General concepts*, Part II: *Damage growth, crack initiation and crack growth*, J. Appl. Mechanics, 55, 1988, 59–71.
- [6] CIEŚLIK J., JAKUBOWSKI J., TAJDUŚ A., *The change of axial stiffness and the development of sandstone samples damage through the conventional triaxial tests*, Kwartalnik Górnictwo i Geoinżynieria, R. 35, z. 2, 2011, 163–170.
- [7] DRAGON A., HALM D., *A mesocrack damage and friction coupled model for brittle materials*, Damage Mechanics in Engineering Materials, 1998, 321–335.

- [8] EL BIED A., SULEM J., MARTINEAU F., *Microstructure of shear zones in Fontainebleau sandstone*, Int. J. Rock Mech. Min. Sci., 39, 7, 2002, 917–932.
- [9] GAMBROTTA L., LAGOMERSINO S., *A microcrack damage model for brittle materials*, Int. J. Solids Structures, 30, 1993, 177–198.
- [10] HALLBAUER D.K., WAGNER K., COOK N.G.W., *Some observations concerning the microscopic and mechanical behavior of quartzite specimens in stiff, triaxial compression tests*, Int. J. Rock Mech. Min. Sci., Vol. 10, 1973, 713–726.
- [11] HORII H., NEMAT-NASSER S., J. Geophys. Res., Vol. 90, No. B4, 1985, 3105–3125.
- [12] KEMENY J.M., COOK N.G.W., *Crack models for the failure of rock under compression*, Proc. 2nd Int. Conf. on Constitutive Laws for Engineering Materials, Theory and Applications, (eds. C.S. Desai, E. Krempl, P.D. Kioussis and T. Kundu) 1, 879–887, Tucson, AZ: Elsevier 1987.
- [13] KRAJČINOVIC D., *Damage Mechanics*, Elsevier 1996.
- [14] KRAJČINOVIC D., MASTILOVIC S., *Some fundamental issues of damage mechanics*, Mech. Matter, 21, 1995, 217–230.
- [15] LEMAITRE J., *A Course of Damage Mechanics*, Springer 1992.
- [16] LITEWKA A., BOGUĆKA J., DEBIŃSKI J., *Deformation induced damage and anisotropy of concrete*, Archives of Civil Engineering, 42, 4, 1996, 425–445.
- [17] LOCKNER D.A., BYERLEE J.D., KUKSENKO V., PONOMAREV A., SIDORIN A., *Quasi-static fault growth and shear fracture energy in granite*, Nature, 350, 1991, 39–42.
- [18] MOORE D.E., LOCKNER D.A., *The role of microcracking in shear-fracture propagation in granite*, J. Struct. Geol., 17, 1995, 5–114.
- [19] PATERSON M.S., WONG T.-F., *Experimental rock deformation – the brittle field*, Second Edition, Springer 2005.
- [20] RAWLING G.C., BAUD P., WONG T.-F., *Dilatancy, brittle strength and anisotropy of foliated rocks: experimental deformation and micromechanical modeling*, J. Geophys. Res. 107, 2002, 2234.
- [21] SKRZYPEK J., *Podstawy Mechaniki Uszkodzeń*, Wydawnictwo Politechniki Krakowskiej, Kraków 2006.
- [22] TOMICZEK K.M., *Damage variable D of rocks under direct tension condition*, Kwartalnik Górnictwo i Geoinżynieria, R 32, z. 1, 2008, 347–358.
- [23] VAJDOVA V., ZHU W., CHEN T.-M.N., WONG T.-F., *Micromechanics of brittle faulting and cataclastic flow in Tavel limestone*, Journal of Structural Geology, 32, 2010, 1158–1169.
- [24] WONG T.-F., *Micromechanics of faulting in westerly granite*, Int. J. Rock Mech. Min. Sci. & Geomech. Abstr., Vol. 19, Issue 2, 1982, 143–160.