

SOME ASPECTS OF JOINING PILES

JAN JAREMSKI

Faculty of Civil and Environmental Engineering, Rzeszów University of Technology,
ul. Powstańców Warszawy 12, 35-959 Rzeszów, Poland.
E-mail: jjaremsk@prz.edu.pl

Abstract: Application of the pile joining is a new solution of the complex pile foundation including the base, made in the ground, and the piles joining the base with the girt. This kind of piles can be used for foundation under special geological conditions (proglacial stream valleys) for foundation reinforcement of the existing buildings and new foundations. The solution proposed may be used in the swelling soils. In this work, the possibilities of applying joining piles in different soils, like fine sands, silts, clays, clay shale, sandstones, which can be the foundation for the piles have been considered.

1. INTRODUCTION

The paper contains a solution of so-called joining piles being a new idea of piling where the basic part of the pile (the base of the high-diameter pile) is located at the depth of the foundation occurrence. Depending on the ground conditions, in many pile structures the basic part of loading is carried by the pile base. The joining pile is an example of such piles. It is a combined foundation including the base made in the soil, and the post elements (a bundle of piles or micropiles) joining the base with the girt (see Figs. 1–3).

Loading is conveyed from the building structure to the carrying ground zone through the bundle of piles (posts) joined at the base with the solid of a big projection zone and volume. The solid is formed of the hardened soil-concrete generated from the deposited aggregate or the degraded rock with cement grout injections. Such a pile allows the loading to be distributed on a large surface; in consequence, load intensity becomes lower. It also allows a base to be made increasing load capacity of the bundle of piles in order to improve soil capacity of the existing foundations located on the grounds of low load capacity and on swelling ground. In many cases, direct capacity of the pile considered can be compared with high-diameter piles because of their base surfaces. The solution put forward is very cheap and its realization does not require any heavy equipment at the building site. It also eliminates a widely applied “forest” of prefabricated piles joined with a plate requiring much more reinforcement than beams joining the piles.

The joining pile is characterized by great ability to transfer horizontal loads, very important in bridge and industrial building (chimneys, etc.). It can also be applied as an anchor pile in small buildings. The piles considered are used for increasing the capacity of existing foundations in the case of a superstructure and deterioration of geotechnical parameters of the base.

The foundation discussed was realized in soils where a layer of gravel-sand soils occurred below layers transferring no loads. In such layers, the pile base can be made with cement paste injection. Such geological conditions usually exist near proglacial valleys and valleys where there are interbeddings of aggrade mud, peat, soft plastic silts, clay, dust especially sensitive to changes of humidity occurring, e.g., during flood events.

So far, the pile bases were made in the gravel layer occurring at the depth of about 5 m below the site by means of an injection of cement paste. Such injection was performed through the holes in a bundle containing, e.g., four posts (prefabricated piles with the holes inside).

There is another advantage of joining piles: they can be used in expansive soils. Such piles have relatively very small lateral surface. Moreover, this allows some forces to be transferred from swelling through anchors located in the holes used for injections. Foundation on traditional piles in swelling soils transferring loadings to non-swelling layers does not protect structures against swelling effects because of the swelling influence on lateral surfaces of the piles. The joining pile is a verified solution for foundation reinforcement in the existing buildings; it can be applied to increase foundation capacity in hazardous situations, also in the case of new solutions of intermediate foundations [7]. The calculations included the possibilities of deviations occurring in post elements with unintended eccentricity of longitudinal force application. For calculation purposes, parameters of the stratified base were assumed because such a base usually occurs in proglacial valleys. The base joining post elements can be made only when a suitable layer exists. Thus, the idea proposed can be realized in proglacial valleys only [6].

Application of the joining piles under different conditions has been considered. Namely, the conditions where there is no layer of non-cohesive soil, and at the level of pile foundation where there are shale clays, shales, sandstones, fine sands, silts, clays, etc., being a base for the element joining the pile heads. It seems possible to make an empty space necessary for generating the pile base by means of an explosive material. The volumes formed could be filled with cement grout [8].

In the solution considered, explosive materials are used while piles are being manufactured. Ammonium saltpetre and potassic saltpetre are proposed as explosive materials; comparable amounts of trinitrotoluene are also considered. This solution was proved feasible by an example from Shanghai, China. Ground anchors were located under the object of relatively large area. That object contains two underground storeys, and soft plastic swelling clays occur at the foundation level. The object is located on the plate mounted by means of 1100 anchors 9 meters in length with a widened base. A necessary volume for the widened base of the anchor was obtained by means of explosion of the explosive material. In such a way, an empty area of a small diameter was obtained at a proper depth in a soft rock. The area was filled with concrete. Ammonium saltpetre and potassic saltpetre were applied as explosive materials, and suitable detonators were used – application of professional procedures could

eliminate accidents. Vibration and noise generated during explosion were smaller than permissible ones. The effects of explosion and generated shocks were analyzed. Noise measurements done in situ during explosions showed from 112 to 116 decibels.

In the opinion of the scientists from China, the solution presented is a new method of foundation anchorage in expansive soils. The applied method of manufacturing is reliable and very good from the economical point of view, and it should be disseminated – the proposed design is safe, relatively cheap and its realization is easy [1].

In the case of soft rocks at the level of pile location, it is also possible to make a head of soils occurring above the eluvia of soft rocks widely assumed as non-carrying subsoil. The author analyses the possibilities of utilizing earlier investigations of application of the pales joining in cohesive soils and the soft rocks. For many pile constructions weathering is the foundation strata and it is very complex to learn its properties and geotechnical parameters considering the difficulty of taking samples of undisturbed structure and the depth which the weathering occupies. The research given in earlier papers can be accepted as model one for the estimation of geotechnical parameters of weathering which is very often the foundation strata for pile constructions [3], [4,]. The results of research of the marl eluvium are ones of the standard laboratory tests of debris with disturbed structure, made successively, and also of model testing made on the samples of weathering with the smallest fractions of simulated variations of moisture content approximated to those occurring in the deposit. The papers presented the results of non-typical investigations “in situ”, with numerical values of geotechnical characteristics being verified [5], [10]. They allow us to determine the optimum bearing capacity of piles, which brings about the possibility of reducing their number and increasing the safety of designed constructions. The determination of the bearing capacity of piles is based on test loads [2], [9].

2. THE COMPLEX PILE MANUFACTURING FOR NEW OBJECTS

In the case of many pile solutions (high-diameter piles) the fundamental part of loadings is transferred by the pile base. The base manufacturing requires high-diameter bore-holes made by means of heavy equipment. Such piles are rather expensive. In such cases, the joining pile can be an alternate solution. In the case of such a pile, at least three prefabricated piles are introduced in a traditional way (by means of a vibrating hammer or a pile driver) at the depth of occurrence of the water bearing layer containing coarse sands and gravel on the surface of min 0.5 m². Next, injection is performed by the axial holes in piles, at least 20 in diameter, where the binding medium (for example, cement grout) is introduced under pressure of 3–150 bars. During injection into the first hole, the moment of occurrence of cement grout in the hole of the alternate pile is determined, and injection pressure treated as preliminary pressure is registered.

The pile base formed after injection and cement grout binding, joined by piles with the girt (the plate joining pile heads) is a complex pile foundation. For example, the joining pile manufactured by introduction of four prefabricated piles of dimensions 80×80 and the spacing about 80 cm forms after injection the base joining pile heads of a diameter comparable with the high-diameter pile of 180 cm in diameter.

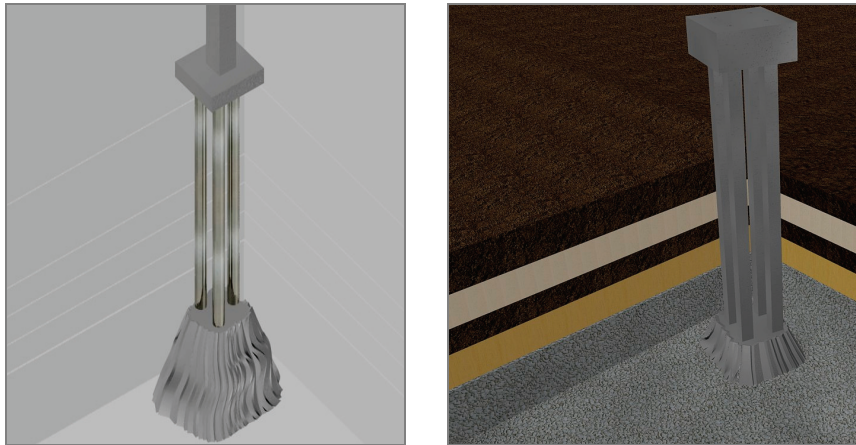

Fig. 1. Computer simulation of the joining pale

3. APPLICATION OF THE PILE IN SWELLING SOILS

Usability of the pile joining in expansive soils is its important advantage. Conventional piles located in swelling soils transfer loadings to non-swelling layers, but they do not protect the structure against effects of swelling because of the action of forces from swelling on lateral surfaces of piles. The joining pile has a relatively small lateral surface. Moreover, it allows some forces to be transferred from swelling through anchors located in the holes for injections, the diameters of which can be enlarged. This solution was successfully applied in two constructions.

Swelling soils are present in many areas of the hot and temperate zones, also in many enclaves of soils and rock eluvia containing minerals belonging to the groups of montmorillonite, illite, etc. Identification of swelling ability and methods of its investigation were described in [11], [13], [14]. Losses caused by soil swelling in building industry are comparable to losses caused by environment.

In the case of swelling soils, the system of piles or micropiles with the base joining their heads plays the role of the anchoring pile. After the injection, the anchors made of steel ribbed bars are introduced through the holes at the depth providing a proper anchorage. The fronts of the piles are bonded with the foundation masonry or the structural post by the steel girts.

In the case of unfavourable soil and water conditions above the base, the micropiles are made by forcing the pipe into the base. At the pipe front there is a taper with a hole for injection. When a proper depth is obtained, injections of the hardening medium are performed into the base, next the pipe with the taper is removed. Concrete mix is introduced into the existing hole, and the micropiles are formed.

4. APPLICATION OF THE PILES AT THE SITES OF FLOOD HAZARD

The author analyzed the influence of flood on small houses existing on the strip foundations on fen clays being out of operation because of the variability of their occurrence and changes of their plasticity. Such sites occur in the glacial valleys and river valleys.



Fig. 2. Computer simulation of the joining pile in the glacial valleys

In the case of river terraces (also in the Podkarpacie region, Poland) the occurring dust clays and dusts settled under water conditions. The layers of fen soils being the youngest layer are the mixture of dusts and clayey minerals of mineralogical structure similar to the soils filling the older terraces. In such soils, the numerical values of the losses of strength approaching zero are registered under humidity greater than 24%. In situ, the fen soils behave similarly to eluvia of soft rocks – reconstruction of coherence takes place and it influences strength [12]. The existing clayey minerals play a similar role like in the rock eluvia of sea origin. In [4], [6], the difficulties of establishing the causes of transfer of marl eluvia from a state typical of cohesive soils to stone debris were discussed. Minerals responsible for swell-

ling and methods for determining the occurrence of illite were presented [4], [5]. The author also analyzed the application of the joining piles where the post elements were made of waste tubes passing through the soils of poor load capacity to the layer of non-cohesive soils (distances from 2.5).

A new method of foundation was proposed. It consists in application of the joining pile (containing two tube piles) at the point of intersection of the shallow footing, and tube piles at the house corners (in the case of longer buildings there are intermediate piles, for example, every 6 meters). The tube is introduced into the soil by means of a servo-motor or a light pile-driver. Cement grout is introduced by filling the tube by portions, forcing or injections. This method can be realized in soils where the layer of sands and gravel occurs below the non-carrying layers. The pile base can be made by injection of cement grout.

Such geological conditions occur usually in the regions of glacial valleys, where we can find interbeddings of aggragate muds, peats, soft plastic dust clays, dusts sensitive to humidity variation (especially during floods). Occurrence of such layer is necessary, so the idea presented can be applied only in the soils of glacial valleys.

The solution proposed is often competitive as compared, for example, with soil exchange because of a high level of underground waters in areas of river terraces.

5. MANUFACTURING JOINING PILES DURING INCREASE OF LOAD-CAPACITY OF THE EXISTING FOUNDATIONS

In the future it will be possible to apply the piles considered in modernized objects made of brick. It is proposed to make the joining piles with the simultaneous introduction of the beams made of steel profiles into the masonry. The beams could transfer loadings from the masonry to the posts-piles. If a frogged storey must be made, the piles could be built over.

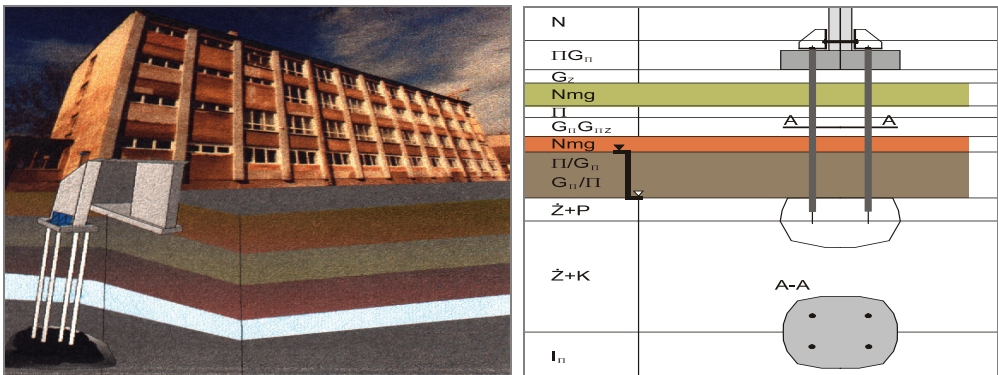

Fig. 3. A scheme of foundation reinforced with a bundle of piles joined by concrete base

How to make such piles when load capacity of the existing foundations is increased? Here is an example. Cracks occurred on the walls and floor cellars in the final phase of the major overhaul of the building. Cracks occurred on the walls in the final phase of the adaptation repair of the building. Also non-uniform deformations caused by ground settlement under a part of the building and the ground swelling were registered. This is caused by vertical cracks on the walls in the cellar in eighteen reinforced concrete cores. The supporting structure of the higher storeys included reinforced concrete frames, combined as a monolith in reinforced concrete finials of the ceilings of channel plates. After 25 years of operating, the internal walls were damaged. During adaptation works the walls were replaced by new ones. The substrate below the building should be consolidated after such a long time, and according to the geodetic measurement results a part of the object was settling, and another part was periodically rising.

Particular layers of the substrate were tested very precisely. All the tests proved a complicated structure of the ground below the building. The soil cooperating with the foundations below the whole house is and will remain the active substrate with variable geotechnical parameters because of swelling, mineralization of organic parts of the soils occurring above the variable level of the underground water. Under the foundation of the building considered, the heads were made – they joined the pile bases made by injection in the gravel layer occurring at the depth of about 5 m.

Injection of cement grout was done through the holes occurring in the bundle of four posts (prefabricated interval piles \varnothing 150 mm and with the internal holes \varnothing 42 mm and length 140 cm). The prefabricated bundle of piles with the base was made under particular cores (hidden posts) in the foundation masonry every 3.0 m under posts of reinforced concrete frames. Such a high-diameter pile under each of 54 posts of the reinforced concrete frames allows a bundle of 4 posts to be joined with the cores by means of a steel girt (2 piles at each side). The girt is an angle bar reinforced at three points and joined with the post by means of 4 bolts \varnothing 50 mm.

Since the swelling properties of the soils occurring along the posts (prefabricated piles) are variable, the piles play an additional role of the anchoring piles.

After injections, the bars made of ribbed steel, 20–40 mm in diameter, were introduced into the holes inside the pile to the length greater than 40 diameters. Injection was performed under pressure depending on the density of the layer of coarse sands and gravel occurring in the subbase.

The joining pile should contain at least 4 prefabricated piles allowing a symmetric injected part of the pile to be made. The prefabricated piles are introduced at the established depth. Assembly was realized according to requirement of the adapted building. The prefabricated piles are interval piles of \varnothing 150 mm – it is the maximum diameter of the drill applied for hole drilling. The ready holes were checked at the building site.

Introduction of the prefabricated element is preceded by making a hole \varnothing 150 mm in the soil by means of the tapered point chisel (see Figs. 1, 3).

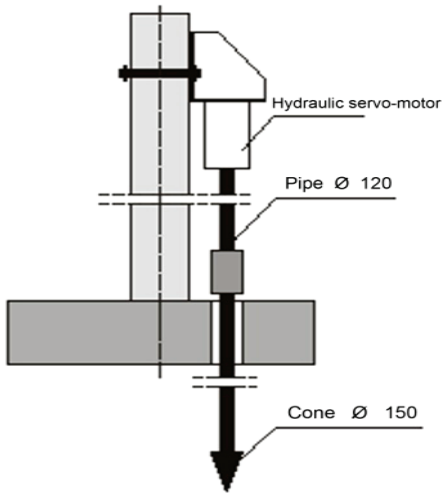

Fig. 4. Diagram of the micropile introduction

In this order, the assembly girt is mounted on the foundation masonry at the height dependent on the servo-motor and the element length. Next, the point chisel was forced into the hole.

The reinforced concrete post elements were introduced into the hole by means of the same hydraulic servo-motor. The main hole is made to the required depth by means of joined sections of thick-walled tubes $\sim\varnothing 100\text{--}140$ mm, joined with the tapered point chisel which allows making a preliminary hole where the pile is introduced. When the taper is introduced to the required depth, the point chisel is removed by means of the hydraulic servo-motor. According to the measurement of pressure, the force of the point chisel introduction was about 80 kN.

Application of the piles considered does not require special equipment for earthwork, especially in the case of an increase of load capacity of the existing foundations in the soils of low load capacity and in the swelling soils.

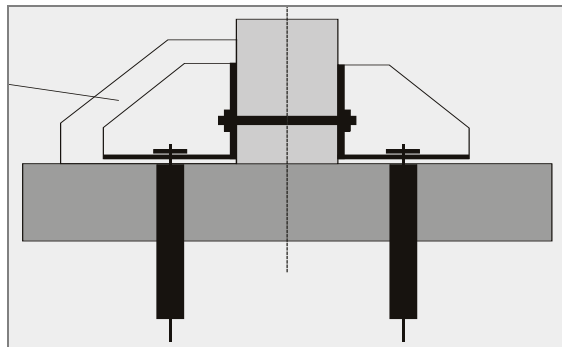

Fig. 5. The connection of butt-end micropiles

The load transfer from the building object to the carrying soil zone through the bundle of micropiles joined at the base by a block of a big projection surface formed by cement grout allows the load to be distributed into a large surface, and in consequence, load intensity can be reduced. This method is much more efficient than other well-known and widely applied methods of increasing the soil load capacity. The connection of butt-end micropiles is as shown in Fig. 5.

6. CONCLUSIONS

1. The planned works lead to the complex analysis of the problems presented and they should consist of tests in situ, model tests, numerical calculations. Determination of the injected zone of ground concrete is also provided. Determination of injection parameters in fluvioglacial soils is also a very important problem.

2. Application of the joining piles seems to be advantageous as compared with foundation of new objects on the high-diameter piles. Such piles are very expensive, and their manufacturing requires heavy boring rigs and much time, as well as application of special equipment.

3. Application of the joining piles does not require special equipment for earthworks, especially in the case of increase of load capacity of the existing foundations in the soils of low capacity and swelling soils.

4. A possibility of applying the joining pile in swelling soils is its very important advantage. Traditional piles applied in swelling soils can transfer loadings to non-swelling soils, but they do not protect the structure against the swelling effects since swelling acts on the lateral surfaces of the piles.

REFERENCES

- [1] GUANZHOU Z., ZHIMING X., *The application of blown tip pile used in the saturated soft soil land single stake economic analysis*, Proc. Int. Conf. on Soil Nailing, Nanjing, 2004.
- [2] GWIZDAŁA K., *Fundamenty palowe*, (in Polish), Wydawnictwo Naukowe PWN S.A., Warszawa, 2008.
- [3] JAREMSKI J., *Characteristic of weathering as foundation strata for pile construction on the basis of the researches of the Opole marls eluvium*, Proc. 4th Int. Conf. Piletalk International, Kuala Lumpur, 1991.
- [4] JAREMSKI J., *The influence of recognition of physical and chemical processes occurring in the weathering in the estimate of the extreme values of geotechnical parameters of the Opole marls eluvium*, Proc. Int. Symp. Geotechnical Engineering of Hard Soils-Soft Rocks, Athens, A.A. Balkema, 1997.
- [5] JAREMSKI J., *The influence of physical and chemical processes occurring in the weathered Opole marls on the geotechnical parameters*, Publishing House of Rzeszów University of Technology, 2005.
- [6] JAREMSKI J., *Increase of micropiles bundle capacity by making a base joining them. Zwiększenie nośności wiązki mikropali przez wykonanie łączącej je podstawy*, (in Polish), XLVI Konferencja Naukowa KILiW PAN i KN PZITB, Krynica, 2000.

- [7] JAREMSKI J., WILK K., *Zwiększenie możliwości wykorzystania pali rzeszowskich do posadowień fundamentów pośrednich*, (in Polish), VI Międzynar. Konf. Naukowa Lwowsko-Koszycko-Rzeszowska, Lwów, 2001.
- [8] JAREMSKI J., *Possibilities of application of rzeszowski pales In cohesive soils and the soft rocks, O możliwościach zastosowania pali rzeszowskich w gruntach spoistych i skalach miękkich*, (in Polish), Zeszyty Naukowe Politechniki Białostockiej, Budownictwo, 2006, z. 28.
- [9] JAREMSKI J., *Creep property of Opole marls weathering on the base of the model laboratory research on the research in situ*, Proc. 7th Int. Cong. on Rocks Mech. Aachen, A.A. Balkema, 1991.
- [10] JAREMSKI J., *Influence of physical and chemical processes occurring in eluvium of the Opole marls and their influence on the geotechnical parameters*, Proceedings of the 7th International Congress IAEG, Lisboa, A.A Balkema, 1994.
- [11] JAREMSKI J., *Proposal for a method determining value of the maximum swelling of soil by example of the Opole marls eluvium and illite clays*, Proc. of 8th Int. Cong. on Rock Mechanics, Tokyo, A.A. Balkema, 1995.
- [12] JAREMSKI J., *The influence of changes of weathering water content on the formation of landslides in the Carpathian Flysch*, Proc. of 9th Australia New Zealand Conference on Geomechanics, Auckland, February 2004, New Zealand Geotechnical Society Inc., 2004.
- [13] JAREMSKI J., *Influence of moisture changes on physico-chemical processes and geotechnical parameters in soft rocks*, Studia Geotechnica et Mechanica, 2010, Vol. XXXII, No. 1.
- [14] JAREMSKI J., *Application of the joining pile for foundations on expansive clays and rocks*, American Academic & Scholarly Research Journal, 2012, Vol. 2, No. 10.