

Grzegorz Michalski
Wroclaw University of Economics

RISK-COST OF CAPITAL RELATION: HOW JEREMIE AND SIMILAR FUNDS DECREASE COST OF CAPITAL RATE FOR SME

Summary: From financial perspective, the JEREMIE fund initiative is profitable and enhances the functioning of micro and small enterprises. Particularly profitable are aspects connected with providing these enterprises with equity capital (i.e. Business Angels, Venture Capital) as well as with the theoretical possibilities connected with reducing the financial risk by over regional institution guarantees (less vulnerable to potential risks occurring in the native region of the micro enterprises engaged in JEREMIE).

Key words: capital cost, target capital structure, micro and small enterprises.

1. Introduction

From financial perspective, the aim of managing an enterprise is to create its value. It is usually achieved by realized undertakings characterized by positive NPV:

$$NPV = \sum_{t=0}^n \frac{CF_t}{(1+CC)^t}$$

In the numerator on the right side of the equation above, there is free cash flow CF realized by the undertaking, while in the denominator on the right side of the equation above, the formula contains the discount rate CC. It stands for the cost of the capital engaged in the realization of the undertaking assessed (regardless of whether it is the first undertaking resulting from the start of the business or a subsequent one – currently continued). Most frequently, an enterprise is financed by the capital coming from a lot of different sources and therefore CC is determined as a weighed mean of the cost rates of the capitals coming from these sources:

$$CC = \sum_{i=1}^n w_i \times k_i, \quad (1)$$

where: w_i – share of capital coming from source i , k_i – cost of capital coming from source i , CC – average weighed capital cost.

Most frequently used form of this formula is:

$$CC = w_{e_i} \times k_{e_i} + w_{d_i} \times k_{d_i} \times (1 - T), \tag{2}$$

where: $w_{e_i} = \frac{E_i}{E + D} =$ – a share (weight of share) of equity capital from source i ,

E – equity capital,
 D – debt,

$w_{d_i} = \frac{D_i}{E + D} =$ – a share (weight of share) of capital coming from i source of debt, $k_{e_i} =$ equity capital cost rate coming from source i , $k_{d_i} =$ cost rate of capital coming from i debt source, $T =$ effective enterprise tax rate.

The undermentioned formula (called Hamada’s equation) is also connected with the problem discussed:

$$\beta_L = \beta_U \left[1 + (1 - T_c) \times \frac{D}{E} \right], \tag{3}$$

where: β_U – beta coefficient of shares for an enterprise with no outstanding debts,
 β_L – beta coefficient of shares for an indebted enterprise,
 T_c – effective tax rate paid by an enterprise.

It shows the relation between a debt level and an increase in the equity capital cost rate, and consequently, the increase in enterprise financing capital cost.

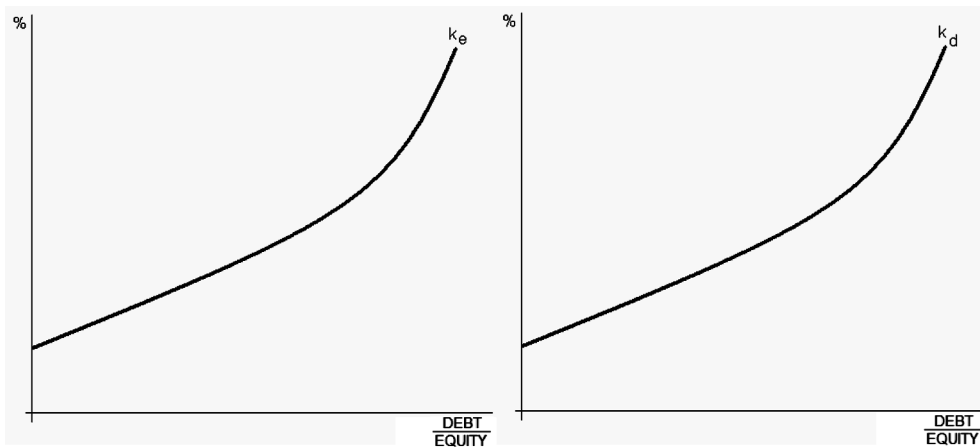

Fig. 1. Debt level influence on the debt cost rates

Source: own study.

The general rule says: the higher enterprise debt is, the higher is a financial risk linked to this business, and consequently, both equity capital cost rates and debt cost rates are higher and higher together with increased debt. Hence, there is a problem of so called “debt capacity”. It is a phenomenon of highly indebted firm, which cannot count on further raising of its debt level (in comparison with equity capital), because the financial risk level influences the height of enterprise financing capital cost rates, and then on the CC level, what makes effective (giving the enterprise value growth) business activity impossible.

JEREMIE (*Joint European Resources for Micro-to-medium Enterprises*), increases the financial potential of micro and small enterprises not only as long as debt is concerned, but the equity capital as well. The European Commission has created the JEREMIE instrument to promote enterprise, innovations and to increase the access to outside financing for micro, small and medium enterprises. It is a common initiative of structural funds. As a ‘Holding Fund’, JEREMIE enables supporting the development of Business Angels (BA), Venture Capital (VC), and increasing the availability of microcredits designed for SME with limited access to commercial credits.

Example 1. An entrepreneur possesses sum A. If he has the makings of financing with the use of loan funds, he is able to obtain (assuming that the capital owned by him is to secure a loan) 2A for his enterprise.

Example 2. An entrepreneur possesses sum A. If he can obtain equity capital thanks to JEREMIE initiative (on the principle VC or BA) equal to sum A (so that he has still 50% + 1 shares/votes in order to keep control over the firm) and if he has the makings for financing with the use of loan funds, he is able to obtain (assuming that the capital owned by him is to secure a loan) 4A for his enterprise.

We received a considerable increase in the development opportunities of SME qualified for such support, mainly thanks to the participation of equity capital providing instruments in JEREMIE initiative.

2. Debt cost rate

With the aim of starting the business activity, as well as its continuation, firms need debt. It has been observed that the debt cost for small enterprises is higher than its counterpart in case of the big ones. The reasons arise from the specific features of small firms. Higher debt cost does not come from irrational prejudices of the small enterprises banking sector entities.

First of all, from the financial perspective, a small firm differs from the big one depending who controls money and who benefits from or loose in case of success or defeat of the firm [Michalski 2005, p. 9-14]. In a small enterprise, it is the owner to be held responsible for all the losses. What is more, the responsibility is most often unlimited. But, he is also the main beneficiary in case of the success. Similarly, money is controlled by the owner of a small firm. Along with the growth of the firm,

these three elements (money control, responsibility for the mistakes and profits) are divided among more and more participants.

Debt cost offered to the enterprises is generally dependent on the money market situation.

Capital price for an enterprise depends on the market conditions (and other effects) in a given period. It is an interest rate in relation to which a bank being the provider of an outside financing sets the cost of credit available for the firm. Inter-bank market finds itself in a direct influence of the Central Bank while the Ministry of Finance influences the market of Treasury bonds. Money market is affected by the monetary policy and national public debt management. Another element which exerts its impact on the money market is an external exchange market. Big changes in the exchange rate and strong expectations of a depreciation or appreciation may significantly influence the structure and size of the demand on money market, and consequently on the interest rate levels and market liquidity value available for the enterprise. The capital cost is as a rule, independent of enterprises. Specially, it is true in case of small and medium firms, which are not the key clients for banks, and therefore hardly have an opportunity to put pressure on their creditors in order to lower the financing-linked charges.

A guarantee of an appropriate enterprise capital supply in a small firm takes place in completely different conditions than in case of big firms. It results, among others, from the fact that the equity capital supply in a small enterprise is completely different, as well as its increase perspectives.

Another handicap for a small firm is its limited access to the capital market. It is also very difficult to take out debt, no matter whether it comes from banks or other sources. Limited influence on own goods and services prices for most small and medium enterprises causes the lack of opportunity of offloading higher costs of this financing onto purchasers [van der Wijst 1989, p. 16-26].

A small enterprise owner constitutes most often the whole, or at least the main part of enterprise management staff. Due to this fact, potential conflicts of agencies: owners – management staff, are eliminated. It should be much to debt suppliers delight. Unfortunately, it is possible that the conflicts of agencies, sometimes even much stronger than expected, will appear in other relations: owner (or his family) – employees (outside the family). Additionally, the owner takes much more of a risk, than his counterparts in big enterprises. Lastly, this conflict may appear on the line: firm owner – capital donors. If a small enterprise is financed by its friends' capital, the agencies conflicts costs are lower, and therefore the financing cost as a whole as well. If capital donors barely know the owner, the relative costs of the gathering of information about him, his firm and monitoring his current situation and actions are much higher than in case of big enterprises obtaining higher capital amounts.

Financial institutions, knowing a statistical small entrepreneur usually find him more risky and irrationally optimistic so think they should offload the average risk related costs connected with such a small firm onto capital recipient.

Information gathering costs are also linked to the agencies cost. There is a double information asymmetry here. Firstly, a small firm owner is much better informed about his specific enterprise situation than potential capital donors [Ang 1991, p. 5-7]. Information asymmetry of this kind causes much more serious problems than in case of big enterprises because:

- fixed cost of the gathering of information about transactions concerning small enterprises is relatively higher for capital donors than the fixed cost connected with big transactions typical for bigger enterprises,
- in case of small enterprises, capital donors have to cope with smaller number of repeatable transactions,
- lower possibilities of instructing specialist agencies to gather financial information about small enterprises, implied by the fact that market of such services is also poorly developed,
- small firms have less tools allowing them to authenticate generated information,
- the quality of information coming from small firms is low and nonstandardized since it is very often that small firms are neither legally nor institutionally obliged to gather and process all information which may be of capital donor's interest in a determined form and even if they tried to adjust to his requirements, management staff incompleteness results in potential mistakes.

Secondly, institutional capital donors most often possess much wider statistical information about small firms in general than an entrepreneur searching for some sources to finance his business activity. The data show that small entrepreneurs more often than the big ones in the same business, experience the difficulties connected with carrying out their responsibilities. Moreover, they are not afraid of taking the risk but reach a very high optimism level at the same time [Meza 1996, p. 375-386]. From such a perspective of the information asymmetry, financial institutions wanting to recompensate additional risk connected with providing small enterprises with capital, raises the capital cost.

Together with the decrease in small enterprise management staff competency, the probability of financial problems increased. Financial problems cost also increases because of the fact that small enterprises experience higher costs of market imperfection and relatively higher charges resulting from it.

In addition the lack of effective limited responsibility for small enterprise's obligations becomes the cause of offloading high financial problems cost to the personal wealth of an owner. Such dangers will force the small enterprise owner to protect himself against increased financial problems and use e.g. smaller leverage. It explains low debt levels which have been observed [Ang 1991, p. 6-8]. Therefore, we may present the interest rate for debt available for a small enterprise in a following way:

$$\text{Cost of debt SME} = \text{Cost of debt for large firm} + \text{SME risk premium} - / + \text{Agency costs premium} + \text{Assymetry information premium}$$

As we can see, debt cost for a big enterprise (as a result of the relations at money market) should be increased by higher risk bonus characteristic for small firms and modified because of agencies costs' influence and information asymmetry.

It is laid open to the charge that within the debt financing, the JEREMIE initiative does not bring additional added value, maybe except for outsourcing functions. However, it is not indeed the case. JEREMIE is an over regional initiative and, if being in fact a guarantee fund is examined as much bigger entity than relatively small local guarantee fund, so the risk reduction degree perceived by creditors will be higher than in case of regional guarantees¹, what results in a lower risk bonus added to debt cost, and consequently, the final debt cost rate, at which the loan is given, will be lower as well as the CC financing SME. It will result in higher efficacy of SME taking advantage of the offer available due to JEREMIE.

3. SME financing capital target structure

The financial aim of an enterprise activity is to create the wealth of its owners. This idea is realized among others by the creation of enterprise value. Enterprise financing capital structure exerts an impact on the average weighed enterprise capital cost rate level and this way on the efficacy level of investment projects realized by the firm. The lower is enterprise capital cost, the higher is enterprise value. Capital structure is a kind of combination of external and equity capital maintained by the enterprise. Capital structure is important for two reasons:

1. Debt cost is lower than the equity capital cost. That means if there were no reason b), the following sentence would be true: "the bigger is a share of debt in enterprise capital structure, the lower is average weighed capital cost, and therefore: the higher is enterprise value".

2. The higher is debt share in the capital structure, the higher is the rate of return required by capital donors because they find the enterprise and its activity more risky. If there were no reason a), the following sentence would be true: "the higher is debt share in enterprise capital structure, the lower is average weighed capital cost, and consequently the higher is enterprise value".

The necessity of offsetting these two reasons leads to the search of optimal capital structure.

¹ It is worth noticing that regional funds are partly exposed to the same risk as SME supported by them. In the JEREMIE initiative is another case – regional risk, being a part of SME business risk is not so important. It is another parameter lowering risk and increasing SME efficacy in the region.

One of the methods of determining the target capital structure is so called a traditional approach. This method is based on the assumption that all the factors influencing or resulting from capital structure should result from aspiring to maximize the enterprise value. Too low the share of debt in enterprise capital structure affects negatively its value for the additional benefits connected with debt usage which are wasted (these benefits result from tax interest shield). On the other hand, however, at first, along with increased debt the enterprise value increases as well, but at one point the disadvantages resulting from debt financing (increased shareholders and creditors risk making them require higher rate of return of capital entrusted) begin to exceed the advantages, causing lowering of enterprise value.

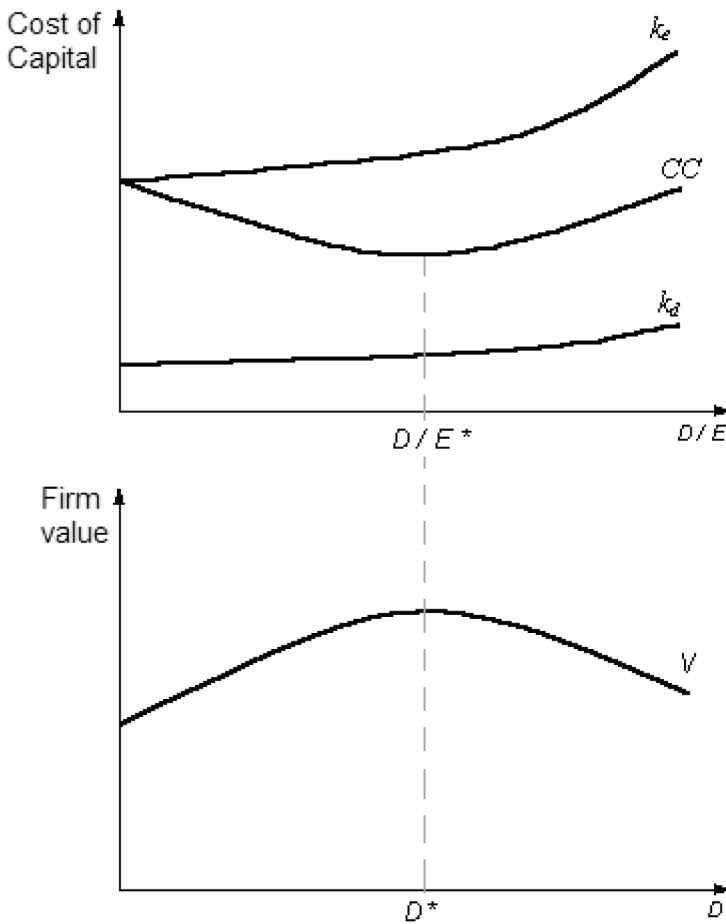

Fig. 2. Target capital structure; D/E^* – traditional approach, where: k_e – cost of equity rate, k_d – cost of debt rate, CC – average cost of capital rate, V – firm value, D/E^* – target / optimal capital structure

Source: [Shapiro, Balbier 2000, p. 470].

This approach predicts that along with the D/E ratio rise, equity capital cost and debt cost also increase and as a result, the average weighed capital cost changes as well. During the initial phase of the D/E ratio rise, capital cost CC decreases, and then increases. The minimum CC level point corresponds to maximal enterprise value.

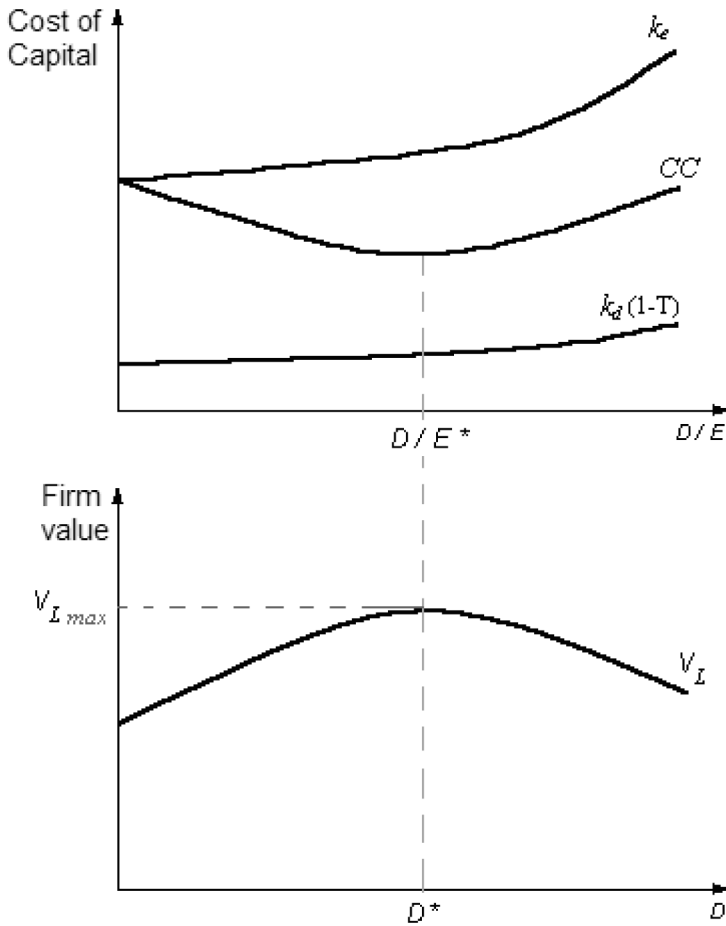

Fig. 3. Target/optimal capital structure – bankruptcy costs approach; where: T – effective tax rate, V_{Lmax} – maximal leveraged firm value

Source: [Ross, Westerfield, Jordan 1999, p. 554].

Similar conclusions result from the static theory of capital structure. Its assumptions are identical to those of Modigliani-Miller model of taxes, except for considering the bankruptcy costs here. The bankruptcy costs are understood as some financial costs resulting from a real enterprise bankruptcy risk. The static theory assumes that the enterprise should increase debt financing until the moment when tax

related profit, being a result of the leverage is equal to bankruptcy costs. The name of this approach originates from the fact that entrepreneur does not make changes in his assets and business activity type, but analyzes only the debt usage changes. According to this approach, capital cost initially decreases due to the leverage benefits effect, and then, exceeding the optimal debt level, starts to increase by reason of increasing bankruptcy costs. The debt financing enterprise value according to the static theory of capital structure is show on fig 3.

The JEREMIE initiative effects on target/optimal SME capital structure emerge in two ways. Firstly – by lowering bankruptcy costs/financial difficulties costs (as a result of the guarantee mechanism effect, more risk reducing than currently operating smaller local funds), the optimal debt point “moves right” (the SME debt capacity increases). Secondly – the V_L curve would be placed higher (whereas the CC curve lower), because equity and debt costs would be lower – it is because for an over regional JEREMIE fund, the lower risk level permits to lower capital rate of return requests.

4. Enterprise optimal investment budget

Outside capital financing enterprises experience the fact that capital cost level changes as its sources from another sources run out. The entrepreneur should firstly use the cheapest sources, and then, when these run out, use the more expensive ones. Average weighed capital cost changes are usually presented as MCC graph, known as a marginal capital cost curve.

The marginal capital cost curve is a curve presenting the relation between marginal capital cost and the capital level needed to finance investment undertakings taken to be completed by the enterprise. It results from arranging financing possibilities from the cheapest ones (assuming that maintaining internal optimal relations between external and equity capital) to the most expensive ones, from the lowest marginal capital cost (*MCC*) to the highest one.

The SME investment possibilities curve presents in turn the most effective investment possibilities available for this SME arranged from the best (with highest IRR) to the least profitable (with lowest IRR).

Optimal investment budget is the enterprise capital amount destined to be spent on investments and resulting from equalizing the marginal capital cost rate and the marginal investment possibilities rate. Obeying to the optimal investment budget is a necessary condition for maximizing the enterprise value. Graphically, the optimal investment budget is determined on the basis of the marginal capital cost curve and the investment possibilities curve intersection.

On figures 4 and 5, both the marginal capital cost curve and the investment possibilities curve are marked. As a result of their interception, the optimal investment budget (I_{OPT}) was obtained.

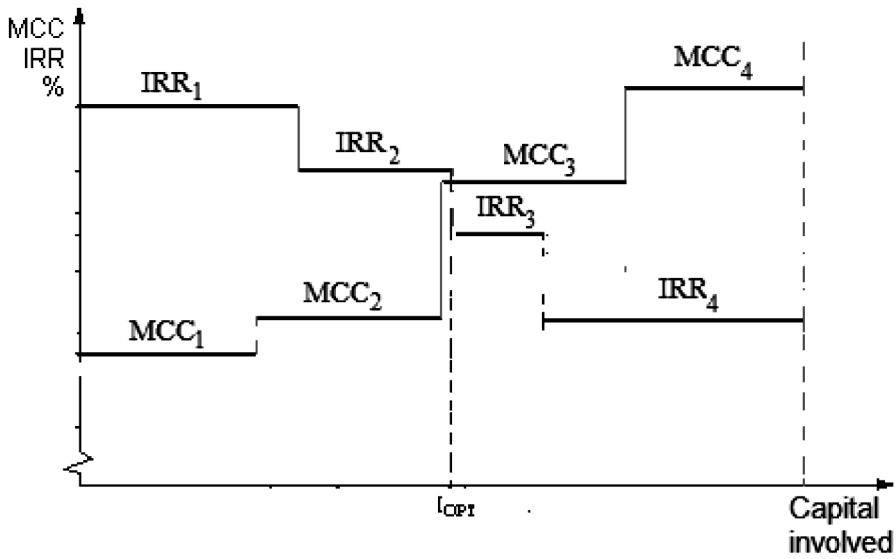

Fig. 4. Optimal budget without JEREMIE

Source: own study.

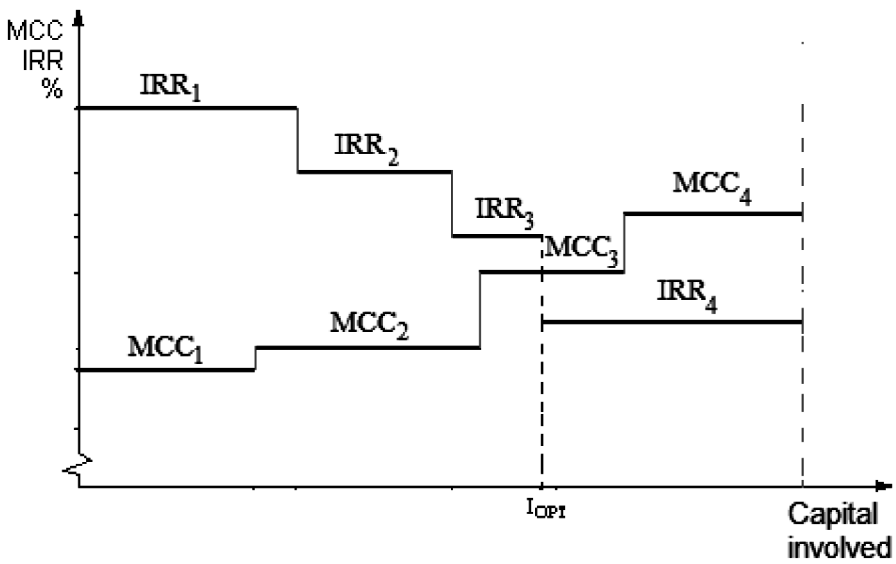

Fig. 5. Optimal budget with JEREMIE

Source: own study.

An access to the JEREMIE initiative by lowering the risk and increased availability of cheaper equity and debts – changes the SME situation by lowering the MCC curve position, what is shown on fig. 5 and 6. As a result, more projects (bigger scale of the same undertaking, there may be still only one project) may be realized since they appear more effective. Optimal investment budgets will be higher after employing the JEREMIE initiative, what constitutes its added value.

This example shows why a precise algorithm for estimating the lacking SME financial means should not be expected. On figure 5, before applying the JEREMIE initiative, the optimal investment budget was lower, and therefore SME uses less money on realized projects. There is a “financial gap” – however, its existence is illustrated by higher capital cost, but not by physical lack of money (there is generally money, but much more expensive – what limits the possibilities of realizing the SME undertakings).

In case shown on figure 6, the optimal investment budget contains already three projects, there will be more money used by SME, but there is still some kind of so called financial gap and the situation may be improved.

5. Conclusion

From purely financial results perspective, the JEREMIE initiative seems to be a profitable proposition, enhancing the functioning of SME. Particularly profitable are aspects connected with providing these enterprises with equity capital (i.e. Business Angels, Venture Capital) as well as with the theoretical opportunities connected with reducing the financial risk by over regional institution guarantees.

Literature

- Ang J.S., *Small business uniqueness and the theory of financial management*, “Journal of Small Business Finance” 1991 no 1(1).
- Meza D., *The Borrower’s curse: optimism*, “Finance and Entrepreneurship, Economic Journal” 1996 no 106(435).
- Michalski G., *Phynność finansowa w małych i średnich przedsiębiorstwach*, Wydawnictwo Naukowe PWN, Warszawa 2005.
- Piotrowska M., *Makroekonomiczne uwarunkowania rynku pieniężnego w Polsce*, Prace Naukowe Akademii Ekonomicznej we Wrocławiu nr 783, AE, Wrocław 1998.
- Ross S.A., Westerfield R.W., Jordan B.D., *Finanse przedsiębiorstw*, Dom Wydawniczy ABC, Kraków 1999.
- Shapiro A.C., Balbier S.D., *Modern corporate finance*, Prentice Hall, Upper Saddle River 2000.
- Van der Wijst D., *Financial structure in small business: theory, tests and applications*, “Lecture Notes in Economics and Mathematical Systems” 1989, vol. 320, Springer-Verlag, Berlin Heidelberg.

RELACJA MIĘDZY RYZYKIEM A KOSZTEM KAPITAŁU: WPLYW JEREMIE I PODOBNYCH FUNDUSZY NA FINANSOWĄ SYTUACJĘ MŚP

Streszczenie: Inicjatywa JEREMIE z finansowego punktu widzenia jest korzystna i poprawia funkcjonowanie mikro- i małych przedsiębiorstw. Szczególnie korzystne są aspekty związane z dostarczaniem tym przedsiębiorstwom kapitału własnego (*business angels, venture capital*) oraz z teoretycznymi możliwościami związanymi ze zmniejszeniem ryzyka finansowego poprzez gwarancje udzielane przez instytucję ponadregionalną (czyli mniej wrażliwą na ewentualne typy ryzyka występujące w regionie, z którego pochodzą mikrofirmy korzystające z JEREMIE).