

Direct Recovery Problem in Incoherent Imaging**

The direct recovery problem, as formulated in the introduction below, was first considered in the papers [1]–[4]. In particular the paper [4] was devoted to the development of a general method of reconstruction of the image and object intensity distribution for incoherent imaging, based on what is called here the incoherent approximation. The present paper is a generalisation of [4] in the sense that the partial coherence introduced by the imaging systems is taken into consideration. For the sake of simplicity the recovery problem has been restricted to the case of no a priori information about the object.

I. Introduction

In a large class of optical imaging procedures the goal is to improve the analysis of the information content of some optical objects. Thus, instead of analyzing the object, we analyze its image, hoping that the latter is better matched to our actual equipment, than the object itself. However, as the information of interest is in the object space rather than in the image plane the question arises: what information about the object may be obtained from the image and to what accuracy. There is a variety of possible approaches to this question starting from traditional problems of image assessment to such modern techniques as image processing or character recognition***. A common feature of almost all the approaches is that the image is usually assumed to be given in the sense that its intensity distribution is known at all the image points. This assumption does not meet the typical experimental conditions of image determination, as the latter is generally limited by two factors: 1) it is possible to collect only a finite number of data about the image as a result of its scanning by an appropriate device; 2) if the data are associated with a particular set of points in the image plane (defined, for example, by positions of the scanning system with respect to the image), they are not identical with the image

intensity at those points****. Thus, the image is practically given in the form of a definite set of measurement results associated with a definite configuration of the properly chosen points in the image plane. We will call this association-measurement representation of the image.

As this measurement representation of the image is not identical with the image intensity distribution, the latter must be recovered in some way. Thus, in a more realistically formulated recovery problem with measurement representation as a starting point we must recover both the image and the object. This approach will be called direct recovery problem, to emphasize the fact that the recovery procedure will start directly from the results of measurement and not from more or less speculative image intensity representation of usually unknown accuracy.

Three approaches to the solution of the direct recovery problem for incoherent imaging were developed in papers [2]–[4] on the base of the terminology proposed in [4]. There the object was assumed to be incoherent and the treatment was approximate as the partial coherence in the image was ignored. The purpose of the present paper is to generalize the method developed in [4] by including the partial

* Address: Instytut Fizyki Technicznej Politechniki Wrocławskiej, Wrocław, Wybrzeże Wyspiańskiego 27, Poland.

** The work done during the author's stay at The Institute of Optics, University of Rochester.

*** For literature see, for example, [5].

**** The relationship between the results of measurement at a particular position of the scanning system and the intensity at the corresponding point in the image plane may be different for different models of the scanning system. A particular construction of the scanner may allow, that the results of measurement may be closer to the said point intensity, than the others. However, the identity is never possible.

coherence into consideration. The other goal will be to discuss the accuracy of reconstruction and obtain some explicit formulas for its estimation. Finally, the role of the a priori knowledge about the object, available before measurement in the recovery procedure and its influence on the reconstruction error will be quantitatively evaluated.

II. Notation, Terminology and Problem Formulation

Before describing the recovery procedure it is convenient to develop terminology for the experimental situation shown in Fig. 1. There, an unknown incoherent object with the intensity distribution $I(\bar{a})$, located in the plane P_0 is imaged to the plane P by an optical system B (referred to below as imaging system) producing the image $I_{\text{im}}(\bar{p})$. Next, the latter is being scanned by an observing system consisting of the imaging part C , producing image of $I_{\text{im}}(\bar{p})$ in the plane Q , where an integrating element E is located. The integrating element E is considered to have the property that the whole light flux falling on it is being absorbed and changed into a signal of different nature (current, voltage or others). For the sake of simplicity we will use the following notation (see Fig. 1)

$\bar{a} = (a, \beta)$ – radius vector in the object plane P_0 ,

$d\bar{a} = da d\beta$,

$\bar{p} = (p, q)$ – radius vector in the image plane P ,

$d\bar{p} = dp dq$,

\bar{a} – position vector of the observing system,

$\bar{u} = (u, s)$ – radius vector in the observation plane A ,

$d\bar{u} = du dv$,

$z_1 z_2$ – object and image distances for imaging system,

$z_1^0 z_2^0$ – object and image distances for observing system.

Under these circumstances the mechanism of measurement result creation in a fixed position \bar{a} of the observing system with respect to the examined image may be described as follows:

As a result of imaging by the system B the incoherent object intensity distribution $I_{\text{ob}}(\bar{a})$

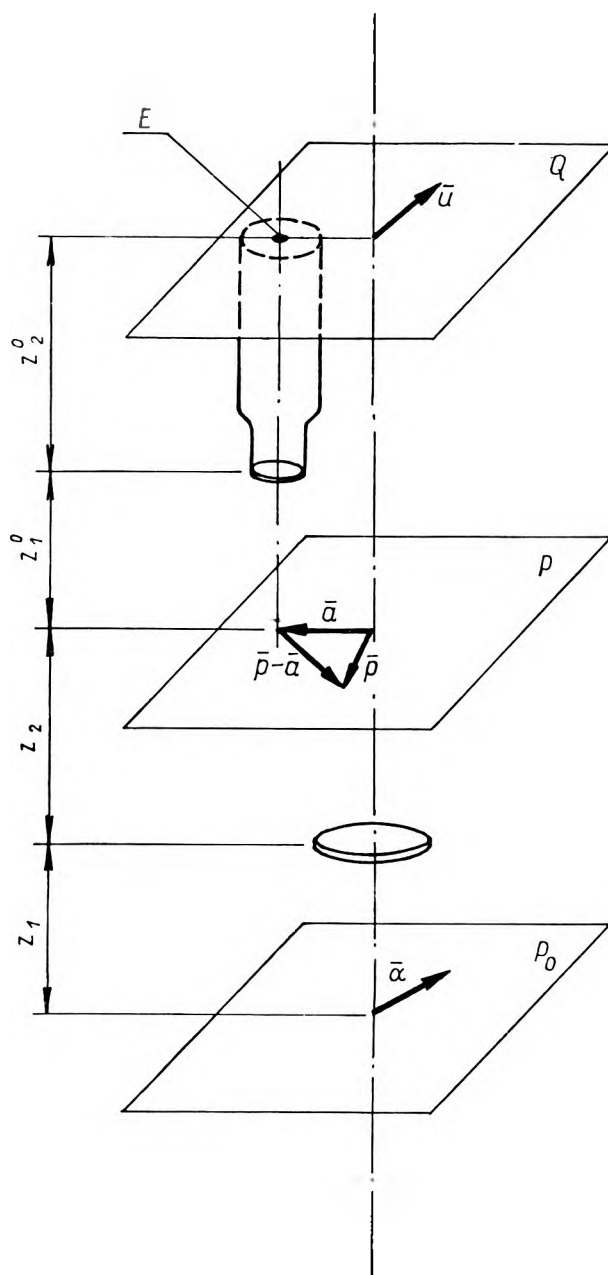

Fig. 1

is transformed into mutual intensity distribution (see, for example, 6)

$$\Gamma(\bar{p}_1, \bar{p}_2) = D \int_{P_0} I(\bar{a}) K_{\text{im}} \left(\frac{\bar{p}_1}{z_2} + \frac{\bar{a}}{z_1} \right) \times K_{\text{im}}^* \left(\frac{\bar{p}_2}{z_2} + \frac{\bar{a}}{z_1} \right) d\bar{a}, \quad (1)$$

where $K_{\text{im}} \left(\frac{\bar{p}_1}{z_1} + \frac{\bar{a}}{z_2} \right)$ is the amplitude spread

function* of the imaging system and

$$K_{\text{im}}^* \left(\frac{\bar{\mathbf{p}}_2}{z_2} + \frac{\mathbf{a}}{z_1} \right)$$

denotes its complex conjugate taken at a different point. The quantity D is of the form

$$D = G(\Lambda_1, \Lambda_2, z_1, z_2, \lambda) \exp \frac{ik(\mathbf{p}_1^2 - \mathbf{p}_2^2)}{2z_2},$$

where inclination factors Λ_1 and Λ_2 , the wavelength λ , and consequently the wave number k are considered to be constant.

Hence, the image intensity distribution $I_{\text{im}}(\mathbf{p})$ may be readily found by setting in (1) $\bar{\mathbf{p}}_1 = \bar{\mathbf{p}}_2$, which yields

$$\begin{aligned} I_{\text{im}}(\bar{\mathbf{p}}) &= G \int_{P_0} I_{\text{ob}}(\bar{\mathbf{a}}) \left| K_{\text{im}} \left(\frac{\bar{\mathbf{p}}}{z_2} - \frac{\bar{\mathbf{a}}}{z_1} \right) \right|^2 d\bar{\mathbf{a}} = \\ &= G \int_{P_0} I_{\text{ob}}(\bar{\mathbf{a}}) \varphi(\bar{\mathbf{p}}, \bar{\mathbf{a}}) d\bar{\mathbf{a}}, \end{aligned} \quad (2)$$

where $\varphi(\bar{\mathbf{p}}, \bar{\mathbf{a}})$ is the intensity spread function of the imaging system. Transformation by the observing system is more complicated and two steps may be distinguished here:

(A) The first step.

Because of the partial coherence in the image introduced by the imaging system B it is mutual intensity $\Gamma(\mathbf{p}_1, \mathbf{p}_2)$ rather than intensity $I_{\text{im}}(\mathbf{p})$ that is subjected to transformation by the optical part C of the observing system located at the position $\bar{\mathbf{a}}$ with respect to the scanned image. Thus, the resulting mutual intensity in the observation plane Q is given by

$$\begin{aligned} \Gamma(\bar{\mathbf{u}}_1, \bar{\mathbf{u}}_2, \bar{\mathbf{a}}) &= D^1 \int \left\{ \Gamma(\bar{\mathbf{p}}_1, \bar{\mathbf{p}}_2) \right. \\ &\quad \left. \exp \left[ik \frac{(\bar{\mathbf{p}}_1 - \bar{\mathbf{a}})^2 - (\bar{\mathbf{p}}_2 - \bar{\mathbf{a}})^2}{2z_1} \right] \right. \\ &\quad \left. \times K_{\text{obs}} \left(\frac{\bar{\mathbf{u}}_1}{z_2^0} + \frac{\bar{\mathbf{p}}_1 - \bar{\mathbf{a}}}{z_1^0} \right) K_{\text{obs}}^* \left(\frac{\bar{\mathbf{u}}_2}{z_2^0} + \frac{\bar{\mathbf{p}}_2 - \bar{\mathbf{a}}}{z_1^0} \right) \right\} \\ &\quad \times d\bar{\mathbf{p}}_1 d\bar{\mathbf{p}}_2 = D'' \int \int \left\{ I_{\text{ob}}(\bar{\mathbf{a}}) K_{\text{im}} \left(\frac{\bar{\mathbf{p}}_1}{z_2} + \frac{\bar{\mathbf{a}}}{z_1} \right) \right. \\ &\quad \left. \times K_{\text{im}}^* \left(\frac{\bar{\mathbf{p}}_2}{z_2} + \frac{\bar{\mathbf{a}}}{z_1} \right) \exp \left[ik \frac{(\bar{\mathbf{p}}_1 - \bar{\mathbf{a}})^2 + (\bar{\mathbf{p}}_2 - \bar{\mathbf{a}})^2}{2z_1} \right] \right. \\ &\quad \left. \times K_{\text{obs}} \left(\frac{\bar{\mathbf{u}}_1}{z_2^0} + \frac{\bar{\mathbf{p}}_1 - \bar{\mathbf{a}}}{z_1^0} \right) K_{\text{obs}}^* \left(\frac{\bar{\mathbf{u}}_2}{z_2^0} + \frac{\bar{\mathbf{p}}_2 - \bar{\mathbf{a}}}{z_1^0} \right) \right\} \\ &\quad \times d\bar{\mathbf{a}} d\bar{\mathbf{p}}_1 d\bar{\mathbf{p}}_2, \end{aligned} \quad (3)$$

* The form of amplitude spread function used in (1) implies assumption of stationarity. All the treatment is essentially true without this assumption as will be pointed out below.

where $D' = G'(\Lambda_1', \Lambda_2', z_1^0, z_2^0, \lambda) \exp ik \left(\frac{u_1^2 - u_2^2}{2z_2} \right)$ with inclination factors Λ_1 and Λ_2 of the observing system considered as constants, and

$$D'' = D \cdot G.$$

Again, the intensity distribution $I(\bar{\mathbf{u}}, \bar{\mathbf{a}})$ in the observation plane Q for the established position of the observing system is obtained by setting in (3) $\bar{\mathbf{p}}_1 = \bar{\mathbf{p}}_2 = \bar{\mathbf{p}}$. Hence

$$\begin{aligned} I(\bar{\mathbf{u}}, \bar{\mathbf{a}}) &= G'' \int \int_{P, P_0} \left\{ I_{\text{do}}(\bar{\mathbf{a}}) K_{\text{im}} \left(\frac{\bar{\mathbf{p}}_1}{z_2} + \frac{\bar{\mathbf{a}}}{z_1} \right) \right. \\ &\quad \left. \times K_{\text{im}} \left(\frac{\bar{\mathbf{p}}_2}{z_2} + \frac{\bar{\mathbf{a}}}{z_1} \right) \exp ik \frac{(\bar{\mathbf{p}}_1 - \bar{\mathbf{a}})^2 + (\bar{\mathbf{p}}_2 - \bar{\mathbf{a}})^2}{2z_1} \right. \\ &\quad \left. \times K_{\text{obs}} \left(\frac{\bar{\mathbf{u}}}{z_2^0} + \frac{\bar{\mathbf{p}}_1 - \bar{\mathbf{a}}}{z_1^0} \right) K_{\text{obs}}^* \left(\frac{\bar{\mathbf{u}}}{z_2^0} + \frac{\bar{\mathbf{p}}_1 - \bar{\mathbf{a}}}{z_1^0} \right) \right\} \\ &\quad \times d\bar{\mathbf{a}} d\bar{\mathbf{p}}_1 d\bar{\mathbf{p}}_2, \end{aligned} \quad (4)$$

where $G'' = G \cdot G'$.

(B) The second step.

Only that part of the intensity distribution $I(\bar{\mathbf{u}}, \bar{\mathbf{a}})$ in the observation plane Q , which falls within the element E , contributes to the measurement. This means, that the actual result of the measurement registered by the observing system at the point $\bar{\mathbf{a}}$ is

$$\bar{x}(\bar{\mathbf{a}}) = \int_E I(\bar{\mathbf{u}}, \bar{\mathbf{a}}) d\bar{\mathbf{u}}. \quad (5)$$

Substitution of (4) into (5) gives

$$\begin{aligned} x(\bar{\mathbf{a}}) &= G'' \int \int \int_E I_{\text{ob}}(\bar{\mathbf{a}}) K_{\text{im}} \left(\frac{\bar{\mathbf{p}}_1}{z_2} + \frac{\bar{\mathbf{a}}}{z_1} \right) \\ &\quad \times K_{\text{im}}^* \left(\frac{\bar{\mathbf{p}}_2}{z_2} + \frac{\bar{\mathbf{a}}}{z_1} \right) \exp \left\{ ik \frac{(\bar{\mathbf{p}}_1 - \bar{\mathbf{a}})^2 - (\bar{\mathbf{p}}_2 - \bar{\mathbf{a}})^2}{2z_1} \right\} \\ &\quad \times K_{\text{obs}} \left(\frac{\bar{\mathbf{u}}}{z_2^0} + \frac{\bar{\mathbf{p}}_1 - \bar{\mathbf{a}}}{z_1^0} \right) K_{\text{obs}}^* \left(\frac{\bar{\mathbf{u}}}{z_2^0} + \frac{\bar{\mathbf{p}}_2 - \bar{\mathbf{a}}}{z_1^0} \right) \\ &\quad \times d\bar{\mathbf{a}} d\bar{\mathbf{p}}_1 d\bar{\mathbf{p}}_2 d\bar{\mathbf{u}}. \end{aligned}$$

Defining

$$\begin{aligned} \varphi(\bar{\mathbf{p}}_1 - \bar{\mathbf{a}}, \bar{\mathbf{p}}_2 - \bar{\mathbf{a}}) &= \int_E \exp ik \frac{(\bar{\mathbf{p}}_1 - \bar{\mathbf{a}})^2 - (\bar{\mathbf{p}}_2 - \bar{\mathbf{a}})^2}{2z_1^0} \\ &\quad \times K_{\text{obs}} \left(\frac{\bar{\mathbf{u}}}{z_2^0} + \frac{\bar{\mathbf{p}}_1 - \bar{\mathbf{a}}}{z_1^0} \right) K_{\text{obs}}^* \left(\frac{\bar{\mathbf{u}}}{z_2^0} + \frac{\bar{\mathbf{p}}_2 - \bar{\mathbf{a}}}{z_1^0} \right) d\bar{\mathbf{u}}, \end{aligned} \quad (6)$$

we will call $\phi(\bar{\mathbf{p}}_1 - \bar{\mathbf{a}}, \bar{\mathbf{p}}_2 - \bar{\mathbf{a}})$ an incoherent instrumental function. Note that the incoherent instrumental function* completely characterizes the observing system including the integrating element. Thus, the result of measurement may be presented in the form

$$x(\bar{\mathbf{a}}) = G'' \int_P \int_{P_0} I_{\text{ob}}(\bar{\mathbf{a}}) K_{\text{im}}\left(\frac{\bar{\mathbf{p}}_1}{z_2} + \frac{\bar{\mathbf{a}}}{z_1}\right) \times K_{\text{im}}^*\left(\frac{\bar{\mathbf{p}}_2}{z_2} - \frac{\bar{\mathbf{a}}}{z_1}\right) \phi(\bar{\mathbf{p}}_1 - \bar{\mathbf{a}}, \bar{\mathbf{p}}_2 - \bar{\mathbf{a}}) d\bar{\mathbf{p}}_1 d\bar{\mathbf{p}}_2 d\bar{\mathbf{a}}, \quad (7)$$

where the roles of the imaging system and observing system in producing the $x(\bar{\mathbf{a}})$ are easily distinguishable.

Now, let the function $x(\bar{\mathbf{a}})$ for all $(\bar{\mathbf{a}}) \in P$, being the measured representation of the image $I_{\text{im}}(\bar{\mathbf{p}})$, obtained by scanning it with the observing system, be called the observed image to distinguish it from the real image $I_{\text{im}}(\bar{\mathbf{p}})$. Let the value $x(\bar{\mathbf{a}}_k)$ for fixed $(\bar{\mathbf{a}}_k)$ be called the observed image point, while the corresponding value of the image intensity $I_{\text{im}}(\bar{\mathbf{a}})_k$ is called the real image point. Then, the recovery problem may be roughly formulated in the following way:

1. Given (in certain sense, for details see the next section) an observed image $x(\bar{\mathbf{a}})$, we wish to recover (in the corresponding sense) the real image $I_{\text{im}}(\bar{\mathbf{p}})$. This problem will be called the direct recovery problem of the image intensity distribution.

2. Given (as above) an observed image $x(\bar{\mathbf{a}})$, we want to recover the object intensity distribution $I_{\text{ob}}(\bar{\mathbf{a}})$. This problem will be called the direct recovery problem of object intensity distribution.

Both the recovery problems are closely related to each other, so that they should be considered jointly rather than separately. It is only for the sake of simpler presentation that we discuss them separately.

III. Direct Recovery Problem of Image Intensity Distribution

In this section we will solve the image recovery problem for the case, when no information

* For detailed interpretation of its physical meaning see [1], where a special case, obtained by neglecting partial coherence in image $I_{\text{im}}(\bar{\mathbf{p}})$, is discussed.

about the object is available before the measurement. Then, from (7)

$$x(\bar{\mathbf{a}}) = D'' \int_P \int_{P_0} I_{\text{ob}}(\bar{\mathbf{a}}) K_{\text{im}}\left(\frac{\bar{\mathbf{p}}_1}{z_2} + \frac{\bar{\mathbf{a}}}{z_1}\right) \times K_{\text{im}}^*\left(\frac{\bar{\mathbf{p}}_2}{z_1} + \frac{\bar{\mathbf{a}}}{z_2}\right) \phi(\bar{\mathbf{p}}_1 - \bar{\mathbf{a}}, \bar{\mathbf{p}}_2 - \bar{\mathbf{a}}) d\bar{\mathbf{p}}_1 d\bar{\mathbf{p}}_2 d\bar{\mathbf{a}}$$

and as can be easily seen from this formula, there is no immediate relation between the observed image $x(\bar{\mathbf{a}})$ and the real image $I_{\text{im}}(\bar{\mathbf{p}})$ given by (2). There are two possible ways of directly relating $x(\bar{\mathbf{a}})$ and $I_{\text{im}}(\bar{\mathbf{p}})$ both at the expense of accuracy of the treatment. The first one consists in ignoring the partial coherence in the real image and was considered in [4], where a detailed solution was given. The other possibility consists in assuming that

$$\phi(\bar{\mathbf{p}}_1 - \bar{\mathbf{a}}, \bar{\mathbf{p}}_2 - \bar{\mathbf{a}}) = \delta(\bar{\mathbf{p}}_1 - \bar{\mathbf{p}}_2)$$

and setting $\bar{\mathbf{p}} = \bar{\mathbf{a}}$ in (2). Then

$$x(\bar{\mathbf{a}}) = I_{\text{im}}(\bar{\mathbf{a}}). \quad (8)$$

However, the last approach is physically unrealizable though it contains suggestions on how to construct the observing system to get the observed image as close to the recovered real image as possible.

We will consider the recovery problem as given by equations (7) and (2) without any artificial simplifications.

There are at least three possible approaches to the problem of the real image recovery:

a. Integral approach: Given the observed image $x(\bar{\mathbf{a}})$ for all points $(\bar{\mathbf{a}}) \in P$, recover the real image $I_{\text{im}}(\bar{\mathbf{p}})$ for all points $(\bar{\mathbf{p}}) \in P$.

As there is no immediate relation between $x(\bar{\mathbf{a}})$ and $I_{\text{im}}(\bar{\mathbf{p}})$ the problem splits into two parts. The first one consists in solving the integral equation

$$x(\bar{\mathbf{a}}) = G'' \int_{P_0} I_{\text{ob}}(\bar{\mathbf{a}}) B(\bar{\mathbf{a}}, \bar{\mathbf{a}}) d\bar{\mathbf{a}} \quad (9)$$

with

$$B(\bar{\mathbf{a}}, \bar{\mathbf{a}}) = \int_P K_{\text{im}}\left(\frac{\bar{\mathbf{p}}_1}{z_2} + \frac{\bar{\mathbf{a}}}{z_1}\right) K_{\text{im}}^*\left(\frac{\bar{\mathbf{p}}_2}{z_2} + \frac{\bar{\mathbf{a}}}{z_1}\right) \times \phi(\bar{\mathbf{p}}_1 - \bar{\mathbf{a}}, \bar{\mathbf{p}}_2 - \bar{\mathbf{a}}) d\bar{\mathbf{p}}_1 d\bar{\mathbf{p}}_2,$$

as the kernel and $I_{\text{ob}}(\bar{\mathbf{a}})$ as the sought function $I_{\text{im}}(\bar{\mathbf{p}})$ may be determined by substituting $I_{\text{ob}}(\bar{\mathbf{a}})$ obtained as a solution of (9), into

$$I_{\text{im}}(\bar{\mathbf{p}}) = \int_{P_0} I_{\text{ob}}(\bar{\mathbf{a}}) \left| K_{\text{im}}\left(\frac{\bar{\mathbf{p}}}{z_1} + \frac{\bar{\mathbf{a}}}{z_2}\right) \right|^2 d\bar{\mathbf{a}}.$$

However, this problem cannot be solved strictly for many reasons. Firstly, from the experimental point of view $x(\bar{\mathbf{a}})$ can be determined for a finite* number of points $(\bar{\mathbf{a}}_k)$, $k = 1, \dots, N < \infty$ rather than for all $(\bar{\mathbf{a}}) \in P$, though an interpolation procedure may be applied to obtain approximate representation of $x(\bar{\mathbf{a}})$ in the plane P . Secondly, from the mathematical point of view it is necessary to prescribe some analytical properties to $I_{\text{ob}}(\bar{\mathbf{a}})$ like continuity and boundedness to make the problem solvable. This requirement may not be met by a real object. Thirdly, there exist only approximate methods of solution of (9), which may be used in this case (see [7]–[9]). Summarizing, the approximation of a solution in this way obtained is very difficult to evaluate, which makes the problem of theoretical rather than practical interest. A solution of this integral approach based on variational methods was obtained in [2] for a special case obtained by neglecting partial coherence in the image.

b. Local approach: Given a single observed image point $x(\bar{\mathbf{a}}_0)$, find the corresponding real image point $I_{\text{im}}(\bar{\mathbf{a}}_0)$. This problem can, in principle, be treated (see [3] for the said special case), but practically, it is never necessary to estimate the real image point $I_{\text{im}}(\bar{\mathbf{a}}_0)$ on the base of one observed image point $x(\bar{\mathbf{a}}_0)$ only, without investigating its surrounding. Thus this formulation is somewhat artificial.

c. General approach: Given a finite set of the observed image points $x(\bar{\mathbf{a}}_k)$ for $(\bar{\mathbf{a}}_k) \in \sigma$, $k = 1, \dots, N$, where σ is a part of the image (of particular interest) chosen for reconstruction. Recover the set of the corresponding real image points $I_{\text{im}}(\bar{\mathbf{a}}_k)$ $k = 1, \dots, N$ and $I_{\text{im}}(\bar{\mathbf{a}})$, $(\bar{\mathbf{a}}) \in \sigma$.

The last approach is in some sense more general, when compared to those defined in a) and b). Namely the local approach can be obtained from it by letting $N = 1$, while the integral approach is received, when $\sigma = P$ and $N \rightarrow \infty$ **.

The main advantage of this formulation consists in the fact that it is both physically pleasing and free of formal difficulties associated with integral approach. For these reasons we restrict

our attention to the recovery problem as formulated in the general approach. A method of its solution will be the subject of the next section.

IV. Method of Image Recovery

As has been mentioned above we are concerned with the image recovery for the case, when no a priori information about the object intensity distribution $I_{\text{ob}}(\bar{\mathbf{a}})$ is available before the measurement. The method of recovery suggested below consists in considering some extreme situations in the object region $\delta = \sigma/\gamma_{\text{im}}^2$, where γ_{im} is the magnification of the imaging system, which are consistent with the given set of the observed image points $x(\bar{\mathbf{a}}_k)$ $k = 1, \dots, N$, and which determine the maximal and minimal possible a posteriori values of the real image points $I_{\text{im}}(\bar{\mathbf{a}}_k)$, $k = 1, \dots, N$. Denoting them by $I_{\text{im}}^{\text{max}}(\bar{\mathbf{a}}_k)$ respectively, we can accept their average values

$$I_{\text{im}}(\bar{\mathbf{a}}_k) = \frac{1}{2} [I_{\text{im}}^{\text{max}}(\bar{\mathbf{a}}_k) + I_{\text{im}}^{\text{min}}(\bar{\mathbf{a}}_k)] \quad k = 1, \dots, N \quad (10)$$

as recovered real image points, while the values

$$\Delta I_{\text{im}}(\bar{\mathbf{a}}_k) = \pm \frac{1}{2} [I_{\text{im}}^{\text{max}}(\bar{\mathbf{a}}_k) - I_{\text{im}}^{\text{min}}(\bar{\mathbf{a}}_k)] \quad (11)$$

as the measure of the maximal possible a posteriori error of reconstruction.

To determine the upper bound values $I_{\text{im}}^{\text{max}}(\bar{\mathbf{a}}_k)$ of the real image points $I_{\text{im}}(\bar{\mathbf{a}}_k)$ consistent with the given set of the observed image points $x(\bar{\mathbf{a}}_k)$ $k = 1, \dots, N$, it is natural to assume that the intensity in the object region σ is concentrated in the points $(\bar{\mathbf{a}}_k)$, which contributes mostly to the corresponding observed points. For the sake of simplicity we shall assume*** that the points $(\bar{\mathbf{a}}_k)$ are related to $(\bar{\mathbf{a}}_k)$ by

$$\bar{\mathbf{a}}_k = \frac{\bar{\mathbf{a}}_k}{\gamma_{\text{im}}}$$

i.e. are identical with the gaussian points in the object plane, optically conjugated with the scanning points $\bar{\mathbf{a}}_k$. This implies that the object intensity distribution is of the form

* Strictly speaking we can do scanning continuously along a line but not across a two-dimensional region.

** Strictly speaking the N must go to infinity so that all the scanning spot distances tended to zero.

*** For the majority of real imaging systems it may be too rough an assumption because of distortion but the corresponding correction is straight forward.

$$I_{\text{ob}}(\bar{\mathbf{a}}) = \sum_{n=1}^N c_n \delta(\bar{\mathbf{a}} - \bar{\mathbf{a}}_n), \quad (12)$$

where c_n are unknown coefficients.

To determine the lower bound values $I_{\text{im}}^{(\text{min})}(\bar{\mathbf{a}}_k)$ of real image points $I_{\text{im}}(\bar{\mathbf{a}}_k)$, still consistent with the same observed image points $x(\bar{\mathbf{a}}_k)$, we shall assume that the intensity in the object region δ is concentrated at the points $\bar{\mathbf{a}}_k$ being located in-between the set of the points $\bar{\mathbf{a}}_k$, as may be seen in Fig. 2. This implies the object intensity distribution to be of the form

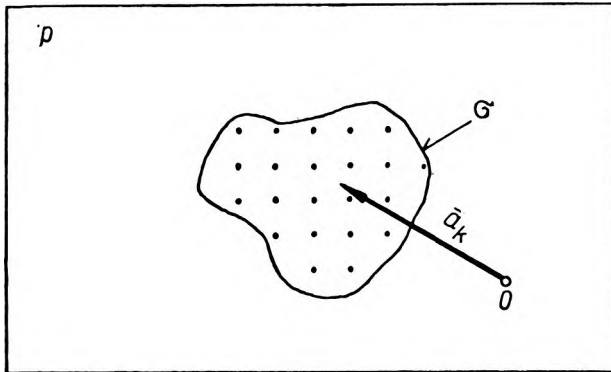

A

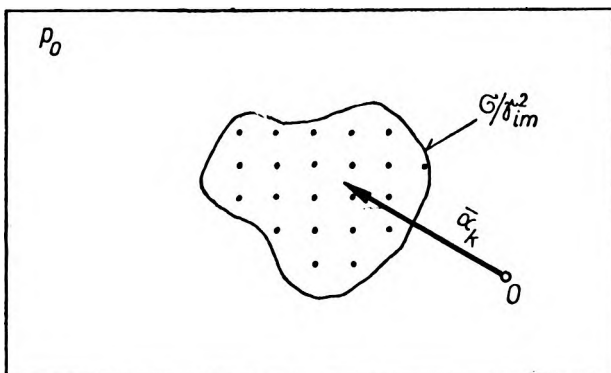

B

Fig. 2

A. Region σ chosen for reconstruction in the image plane. O-point of intersection with optical axis

B. Corresponding region $\sigma/\gamma_{\text{im}}^2$ in the object plane P_0 .

$$\bar{\mathbf{a}}_k = \bar{\mathbf{a}}_k/\gamma_{\text{im}}$$

$$I_{\text{ob}}(\bar{\mathbf{a}}) = \sum_{n=1}^N c'_n \delta(\bar{\mathbf{a}} - \bar{\mathbf{a}}'_k), \quad (13)$$

where c'_n for $n = 1, \dots, N$, is another set of unknown quantities.

In order to evaluate c_n and c'_n in a unique way we substitute successively (12) and (13) into (7) for $\bar{\mathbf{a}} = \bar{\mathbf{a}}_k$, $k = 1, \dots, N$. After a rearrangement we obtain

$$x(\bar{\mathbf{a}}_k) = \sum_{n=1}^N c_n B_{nk} \quad (14a)$$

$$k = 1, \dots, N$$

$$x(\bar{\mathbf{a}}_k) = \sum_{n=1}^N c'_n B'_{nk} \quad (14b)$$

where*

$$B_{nk} = B(\bar{\mathbf{a}}_n, \bar{\mathbf{a}}_k) = \int_{P_0} \delta(\bar{\mathbf{a}} - \bar{\mathbf{a}}_n) B(\bar{\mathbf{a}}, \bar{\mathbf{a}}_k) d\bar{\mathbf{a}} \quad (15a)$$

$$B'_{nk} = B(\bar{\mathbf{a}}'_n, \bar{\mathbf{a}}_k) = \int_{P_0} \delta(\bar{\mathbf{a}} - \bar{\mathbf{a}}'_n) B(\bar{\mathbf{a}}, \bar{\mathbf{a}}_k) d\bar{\mathbf{a}} \quad (15b)$$

and $B(\bar{\mathbf{a}}, \bar{\mathbf{a}}_k)$ is defined by (9) for $\bar{\mathbf{a}} = \bar{\mathbf{a}}_k$.

Let us call the matrices of the equation systems (14a) and (14b)

$$B_{nk} \quad \text{and} \quad B'_{nk}$$

the upper and lower bound reconstruction matrices for the incoherent imaging respectively. The matrices contain all the information about the imaging and observing systems necessary for reconstruction. From (9) and (15a, b) we have

$$B_{nk} = \int_{\bar{P}} K_{\text{im}} \left(\frac{\bar{\mathbf{p}}_1}{z_2} + \frac{\bar{\mathbf{a}}_n}{z_1} \right) K_{\text{im}}^* \left(\frac{\bar{\mathbf{p}}_2}{z_2} + \frac{\bar{\mathbf{a}}_k}{z_1} \right) \times \phi(\bar{\mathbf{p}}_1 - \bar{\mathbf{a}}_k, \bar{\mathbf{p}}_2 - \bar{\mathbf{a}}_k) d\bar{\mathbf{p}}_1 d\bar{\mathbf{p}}_2 \quad (16)$$

and

$$B'_{nk} = \int_{\bar{P}} K_{\text{im}} \left(\frac{\bar{\mathbf{p}}_1}{z_1} + \frac{\bar{\mathbf{a}}_n}{z_1} \right) K_{\text{im}}^* \left(\frac{\bar{\mathbf{p}}_2}{z_2} - \frac{\bar{\mathbf{a}}_k}{z_1} \right) \times \phi(\bar{\mathbf{p}}_1 - \bar{\mathbf{a}}_k, \bar{\mathbf{p}}_2 - \bar{\mathbf{a}}_k) d\bar{\mathbf{p}}_1 d\bar{\mathbf{p}}_2.$$

Thus, the information required on the part of the imaging system has been reduced to the knowledge of amplitude spread function around the object points $\bar{\mathbf{a}}_n$ and $\bar{\mathbf{a}}_n$, while the observing system is represented by its instrumental function centered at the scanning points $\bar{\mathbf{a}}_k$. The physical meaning of the matrix elements B_{nk} and B'_{nk} may be easily deduced from (14a) and (b). They are simply measures of the relative contributions to each observed point $x(\bar{\mathbf{a}}_k)$ from each object point $\bar{\mathbf{a}}_n$ and $\bar{\mathbf{a}}'_n$ respectively, when the object intensity coefficients c_n and c'_n are normalized to 1. The solution of the linear systems of equations (14a) and (14b) with respect to c_n and c'_n is straightforward. The roots are simply given by

* The integration in (15) over the definite region P_0 implies that $\bar{\mathbf{a}}_n \in \delta \epsilon P_0$ which is in accordance with our treatment of the recovery problem.

$$c_n^N = \frac{\begin{vmatrix} B_{1,1}, \dots, B_{1,n-1}, x_1, B_{1,n+1}, \dots, B_{1,N} \\ \vdots \\ B_{N,1}, \dots, B_{N,n-1}, x_N, B_{N,n+1}, \dots, B_{N,N} \end{vmatrix}}{|\{B_{n,k}\}|} \quad (17a)$$

$$c_n'^N = \frac{\begin{vmatrix} B'_{1,1}, \dots, B'_{1,n-1}, x_1, B'_{1,n+1}, \dots, B'_{1,N} \\ \vdots \\ B'_{N,1}, \dots, B'_{N,n-1}, x_N, B'_{N,n+1}, \dots, B'_{N,N} \end{vmatrix}}{|\{B'_{n,k}\}|} \quad (17b)$$

where $x_k = x(\bar{a}_k)$, $k = 1, \dots, N$. The notation c_n^N and $c_n'^N$ takes into account the fact that the recovery in the region σ under consideration is limited to N measurements. It may be interesting to notice that in consequence of linearity of (14a, b) the recovered values c_n^N and $c_n'^N$ have been determined uniquely by x_1, \dots, x_n , provided that the reconstruction matrices B_{nk} and B'_{nk} are nonsingular. In particular, if $x_1 = \dots = x_N = 0$ then $c_n^N = c_n'^N = 0$ for $n = 1, \dots, N$, the result being in accordance with the measurement intuition.

Consequently, the extreme possible a posteriori distribution of object intensity, consistent with the observed image points $x(\bar{a}_k)$, is also uniquely reconstructed (within the region σ) in the form of equations

$$I_{\text{ob}}^{(\text{max})}(\bar{a}) = \sum_{n=1}^N c_n^N \delta(\bar{a} - \bar{a}_n), \quad (18a)$$

$$I_{\text{ob}}^{(\text{min})}(\bar{a}) = \sum_{n=1}^N c_n'^N \delta(\bar{a} - \bar{a}'_n). \quad (18b)$$

Substituting (18) into (2) gives two estimations of image intensity distribution

$$\begin{aligned} I_{\text{im}}^{(\text{max})}(\bar{p}) &= \int_{P_0} I_{\text{ob}}^{(\text{max})}(\bar{a}) \varphi(\bar{p}, \bar{a}) d\bar{a} \\ &= \sum_{n=1}^N c_n^N \varphi(\bar{p}, \bar{a}_n) \end{aligned} \quad (19a)$$

and

$$\begin{aligned} I_{\text{im}}^{(\text{min})}(\bar{p}) &= \int_{P_0} I_{\text{ob}}^{(\text{min})}(\bar{a}) \varphi(\bar{p}, \bar{a}) d\bar{a} \\ &= \sum_{n=1}^N c_n'^N \varphi(\bar{p}, \bar{a}'_n). \end{aligned} \quad (19b)$$

The first of them (19a) has the property that at the points $\bar{p} = \bar{a}_k$ the image intensity takes the maximal possible a posteriori values equal to

$$I_{\text{im}}^{(\text{max})}(\bar{a}_k) = \sum_{n=1}^N c_n^N \varphi(\bar{a}_k, \bar{a}_n), \quad (20a)$$

consistent with the $x(\bar{a}_k)$ for $k = 1, \dots, N$, while the second reconstruction (19b) takes the minimal possible a posteriori values (for $\bar{p} = \bar{a}_k$) equal to

$$I_{\text{im}}^{(\text{min})}(\bar{a}_k) = \sum_{n=1}^N c_n'^N \varphi(\bar{a}_k, \bar{a}'_n), \quad (20b)$$

the latter being also consistent with the same set of the observed image points. Again, substituting (20a and b) into (10) and (11), we obtain respectively

$$\begin{aligned} I_{\text{im}}(\bar{a}_k) &= \frac{1}{2} [I_{\text{im}}^{(\text{max})}(\bar{a}_k) + I_{\text{im}}^{(\text{min})}(\bar{a}_k)] \\ &= \frac{1}{2} \sum_{n=1}^N [c_n^N \varphi(\bar{a}_k, \bar{a}_n) + c_n'^N \varphi(\bar{a}_k, \bar{a}'_n)] \end{aligned} \quad (21)$$

$k = 1, \dots, N$

as the reconstructed real image points corresponding to the observed image points $x(\bar{a}_k)$, and

$$\begin{aligned} \Delta I_{\text{im}}(\bar{a}_k) &= \pm \frac{1}{2} [I_{\text{im}}^{(\text{max})}(\bar{a}_k) - I_{\text{im}}^{(\text{min})}(\bar{a}_k)] \\ &= \pm \frac{1}{2} \sum_{n=1}^N [c_n^N \varphi(\bar{a}_k, \bar{a}_n) - c_n'^N \varphi(\bar{a}_k, \bar{a}'_n)] \end{aligned} \quad (22)$$

as the measure of the reconstruction error. It is worth noticing that in the final formulas (21) and (22) the intensity spread function is represented only by its N^2 values taken at the points \bar{a}_k and \bar{a}'_n , $n, k = 1, \dots, N$. However, the evaluation of the upper and lower bound reconstruction matrices elements B_{nk} and B'_{nk} necessary for the determination of c_n^N and $c_n'^N$ requires the knowledge of amplitude spread function of the imaging system. This makes the practical application of the developed method complicated by the fact that the lens designers do not have methods for exact evaluation of the amplitude spread functions for the majority of the real systems. However, some reasonable approximations may be made. If, for example, the imaging systems, as well as the optical part of the observing system, are good enough to be considered to a good approximation as diffraction limited, then we have exact expressions for their amplitude spread function in the case of a circular aperture (see, for instance, [6]). The other approximate

treatment, as indicated above, may consist in neglecting the partial coherence in the image plane and then the problem is formulated in terms of intensity spread functions of both the imaging and observing part of the whole optical system. The last approach has been widely discussed in [4].

Finally, it is important that the formulas (19a, b) provide a very natural and convenient interpolation procedure to evaluate the image intensity in the vicinity of the scanning points $\bar{\mathbf{a}}_k$. It is obvious to assume $I_{\text{im}}(\bar{\mathbf{p}})$ for $(\bar{\mathbf{p}}) \in \sigma$ in the form

$$I_{\text{im}}(\bar{\mathbf{p}}) = \frac{1}{2} [I_{\text{im}}^{(\text{max})}(\bar{\mathbf{p}}) + I_{\text{im}}^{(\text{min})}(\bar{\mathbf{p}})]$$

$$= \sum_{n=1}^N [c_n^N \varphi(\bar{\mathbf{p}}, \bar{\mathbf{a}}_n) + c_n'^N \varphi(\bar{\mathbf{p}}, \bar{\mathbf{a}}_n')]. \quad (23)$$

Note that strictly speaking the error of this representation of image intensity distribution is unknown except for the points $\bar{\mathbf{p}} = \bar{\mathbf{a}}_k$. However, in the most cases it may be assumed that the error of the reconstructed values of $I_{\text{im}}(\bar{\mathbf{p}})$ at all $(\bar{\mathbf{p}})$ within the region contained between any four closest scanning points does not exceed the value of the largest error for those four points.

V. Direct Recovery Problem for Object Intensity Distribution

When developing the method of real image recovery, we have uniquely determined two object intensity distributions, which were presumed to be the extreme possible a posteriori situations still consistent with the given set of the observed measurement points. Thus, we have shown that if no information about the object was available in the examined region before measurement, we are forced to admit a vast class of possible a posteriori object intensity distributions contained between

$$I_{\text{ob}}^{(\text{max})}(\bar{\mathbf{a}}) = \sum_{n=1}^N c_n^N \delta(\bar{\mathbf{a}} - \bar{\mathbf{a}}_n)$$

and

$$I_{\text{ob}}^{(\text{min})}(\bar{\mathbf{a}}) = \sum_{n=1}^N c_n'^N \delta(\bar{\mathbf{a}} - \bar{\mathbf{a}}_n')$$

as limiting cases (see Eq. (18a, b)). One of those distributions, which seems to be more adequate to the common intuition, is the half-tone screen object representation, which may be easily obtained from (18) in the following way.

VI. Method of Object Recovery Involving the Half-Tone Screen Approximation

Let the region $\theta = \sigma/\gamma_{\text{im}}^2$ in the object space be divided into small cells θ_k centred at the points $(\bar{\mathbf{a}}_k)$ (see Fig. 3a) or into cells θ_k' around the points $(\bar{\mathbf{a}}_k)'$ (see Fig. 3b). Now, let the object intensity, concentrated at the points $(\bar{\mathbf{a}}_k)$ and

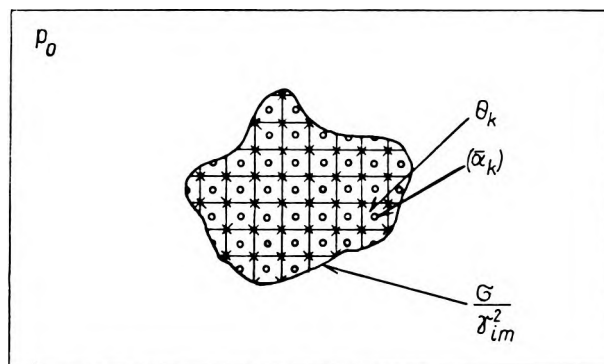

A

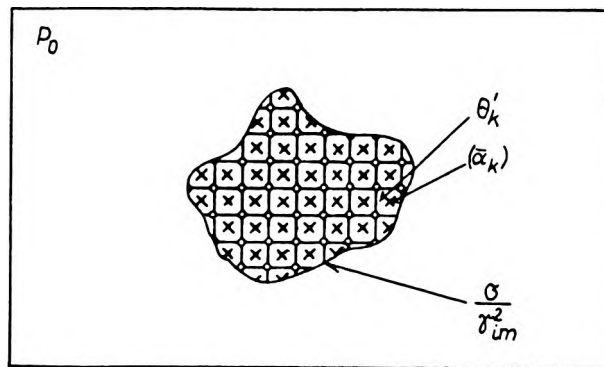

B

Fig. 3

A. Regions θ_k of the upper bound half-tone screen
B. Regions θ_k' of the lower bound half-tone screen

uniquely determined by the upper bound reconstruction procedure, be spread in some way over the corresponding regions θ_k . If we assume a uniform spreading within the regions θ_k , then the resultant intensity within each of them may be described as follows:

$$I_{\text{ob}}[(\bar{\mathbf{a}}) \in \theta_k/x, \dots, x_n] = \frac{1}{\theta_k} \int_{\theta_k} c_k^N \delta(\bar{\mathbf{a}} - \bar{\mathbf{a}}_k) d\bar{\mathbf{a}}$$

$$= \frac{c_k^N}{\theta_k} \quad k = 1, \dots, N. \quad (24a)$$

By applying the same procedure to the lower bound recovery, we get from (18a)

$$I_{\text{ob}}[(\bar{\mathbf{a}}) \in \theta'_k/x, \dots, x_N] = \frac{1}{\theta'_k} \int_{\theta'_k} c_k'^N \delta(\bar{\mathbf{a}} - \bar{\mathbf{a}}'_k) d\bar{\mathbf{a}}$$

$$= \frac{c_k'^N}{\theta'_k} \quad k = 1, \dots, N. \quad (24b)$$

As the object intensity distribution, recovered to the half-tone screen approximation, we can assume either

$$I_{\text{ob}}((\bar{\mathbf{a}}) \in \theta/x, \dots, x_N) =$$

$$= \sum_{k=1}^N I_{\text{ob}}[(\bar{\mathbf{a}}) \in \theta_k/x, \dots, x_N] = \sum_{k=1}^N \frac{c_k^N}{\theta_k} \quad (25)$$

or

$$I_{\text{ob}}((\bar{\mathbf{a}}) \in \theta/x, \dots, x_N) =$$

$$\sum_{k=1}^N I_{\text{ob}}[(\bar{\mathbf{a}}) \in \theta'_k/x, \dots, x_N] = \sum_{k=1}^N \frac{c_k'^N}{\theta'_k} \quad (26)$$

or finally

$$I_{\text{ob}}((\bar{\mathbf{a}}) \in \theta) =$$

$$= \frac{1}{2} \{ I_{\text{ob}}[(\bar{\mathbf{a}}) \in \theta/x, \dots, x_N] + I'_{\text{ob}}[(\bar{\mathbf{a}}) \in \theta/x, \dots, x_N] \}$$

$$= \frac{1}{2} \sum_{k=1}^N \left(\frac{c_k^N}{\theta_k} + \frac{c_k'^N}{\theta'_k} \right). \quad (27)$$

Note that as the expressions $\frac{c_k^N}{\theta_k}$ and $\frac{c_k'^N}{\theta'_k}$ are functions of $(\bar{\mathbf{a}})$ of the type

$$\frac{c_k^N}{\theta_k} = \begin{cases} c_k^N/\theta_k & \text{for } (\bar{\mathbf{a}}) \in \theta_k; \\ 0 & \text{otherwise} \end{cases}$$

$$\frac{c_k'^N}{\theta'_k} = \begin{cases} c_k'^N/\theta'_k & \text{for } (\bar{\mathbf{a}}) \in \theta'_k; \\ 0 & \text{otherwise} \end{cases}$$

The summation in (25)–(27) consists in adding rectangular functions rather than constant values. Considering c_k^N and $c_k'^N$ as rectangular functions of $\bar{\mathbf{a}}$ given by

$$c_k^N = \begin{cases} c_k^N & \text{for } (\bar{\mathbf{a}}) \in \theta_k; \\ 0 & \text{otherwise} \end{cases};$$

$$c_k'^N = \begin{cases} c_k'^N & \text{for } (\bar{\mathbf{a}}) \in \theta'_k; \\ 0 & \text{otherwise} \end{cases},$$

we can simplify the formulas (25)–(27) for the case, when $\theta_k = \theta'_k = \theta_0$ for $k = 1, \dots, N$. Then (25), (26) and (27) become respectively

$$I_{\text{ob}}[(\bar{\mathbf{a}}) \in \theta_k/x, \dots, x_N] = \frac{1}{\theta_0} \sum_{k=1}^N c_k^N, \quad (25a)$$

$$I_{\text{ob}}[(\bar{\mathbf{a}}) \in \theta'_k/x, \dots, x_N] = \frac{1}{\theta_0} \sum_{k=1}^N c_k'^N, \quad (26a)$$

$$I_{\text{ob}}[(\bar{\mathbf{a}}) \in \theta] = \frac{1}{2\theta_0} \sum_{k=1}^N (c_k^N + c_k'^N). \quad (27a)$$

It is easy to notice that formula (27a) is equivalent to dividing each sampling cell θ_k (or θ'_k) into four equal parts and taking the average value of overlapping functions c_k^N and $c_k'^N$ in each of them.

VII. Concluding remarks

The goal of the present paper was to suggest a method of solving the direct recovery problem, consisting in both the image and object reconstruction starting with their measurement representation. For the sake of simplicity we have restricted our consideration to the case, when no a priori information about the object is available before the measurement.

There are two points which should be emphasized here.

Firstly, even if there is absolutely no a priori information about the object the image recovery may be successfully considered in a reasonable way and the recovered image representation (23) is physically pleasing. In contrast to that the reconstructed object representations (18a, b) are almost unpalatable. The alternative object representations (25), (26) and (27), obtained by assuming the halftone structure of the object, seem to be more appealing. However, the said assumption can not be rigorously justified in the case of the complete a priori ignorance.

Secondly, this unfortunate situation results in the fact, that no theoretically satisfactory measure of the object reconstruction error

can be obtained. This is again in contrast to the image recovery where the formula (22) for the maximal a posteriori reconstruction error at the image points (a_k) is physically pleasing.

This means that also in the direct recovery problem as formulated in this paper almost no information about the object intensity distribution can be gained without some a priori knowledge about it; the fact being well known in the literature for the differently (and as a rule less realistically) formulated reconstruction procedures.

Fortunately, in practice we are never in a position of absolute a priori ignorance. Almost always the up to now experience would suggest what kind of choice should be taken among the available object representations, even if we have no quantitatively expressible arguments to justify this selection. For instance we would accept the representations (25)–(27) rather than those expressed by the formulas (18a, b).

For this reason the influence of the a priori information on the recovery procedure and its accuracy should be carefully discussed. We will give an analysis of the subject in the next paper.

Problème de la reconstruction immédiate dans l'image incohérente

Le problème de la reconstruction immédiate sous la forme donnée dans l'introduction a été étudié pour la première fois dans les travaux [1]–[4]. En particulier, le travail [4] a été consacré à la méthode générale de reconstruction immédiate de la distribution

d'intensité dans l'objet et dans l'image en approximation dite incohérente. Le présent travail est une généralisation du problème traité dans [4]; on y prend en considération la cohérence partielle introduite par le système optique. Pour faciliter les considérations on se borne au cas où il n'y a à priori aucune information sur l'objet optique.

Проблема непосредственной реконструкции при некогерентном изображении

Вопрос непосредственной реконструкции, который приводится в введении, первый раз обсуждался в работах [1]–[4]. В частности работа [4] посвящена была общему методу непосредственной реконструкции распределения интенсивности в предмете и изображении при так называемом некогерентном приближении. Эта работа является обобщением [4], заключающимся в том, что учитывается частичная когерентность, введенная отображающей системой. Для упрощения рассуждений ограничились только к случаю, когда нет никакой информации об оптическом предмете.

References

- [1] WILK I., Zesz. Nauk. Pol. Wrocł. Nr 214, Fizyka XV, 1969, p. 11.
- [2] WILK I., Prace Nauk. Inst. Fiz. Techn. Pol. Wrocł. Nr 2, Studia i Materiały Nr 2, 1969, p. 8.
- [3] WILK I., Prace Nauk. Inst. Fiz. Techn. Pol. Wrocł. Nr 2, Studia i Materiały Nr 2, 1969, p. 23.
- [4] WILK I., Prace Nauk. Inst. Fiz. Techn. Pol. Wrocł. Nr 4, Studia i Materiały Nr 4, 1970, p. 1.
- [5] GOODMAN J. W., *Fourier Optics*, McGraw-Hill 1968.
- [6] THOMPSON B. J., *Progress in Optics*, Vol. VII, 1969.
- [7] MICHLIN S. G., *Integral Equation*, Moscow–Leningrad 1949 (in Russian).
- [8] MICHLIN S. G., SMOLICKIJ H. L., *Approximation Methods in Differential Equation Solution*, Izd. „Nauka”, Moscow 1965 (in Russian).
- [9] CLAF L. J., *Variational Calculus and Integral Equations*, Izd. „Nauka”, Moscow 1966 (in Russian).