

Spectral Sensitivity of the Photovoltaic Effect in $\text{Cd}_x\text{Hg}_{1-x}\text{Te}$ p - n Junctions

In a p -type monocrystalline $\text{Cd}_{0.2}\text{Hg}_{0.8}\text{Te}$ the p - n junctions have been produced by annealing the crystal in mercury atmosphere. Spectral characteristics of the photovoltaic effect in the junctions have been measured for wavelength ranging from $1\mu\text{m}$ to $15\mu\text{m}$. Maximum sensitivity $S_{\text{max}} = 2\text{ V/W}$ has been found for $\lambda = 5.6\mu\text{m}$, at 77 K .

1. Introduction

A three-component mixed crystal $\text{C}_x\text{Hg}_{1-x}\text{Te}$ is a semiconductor in which the energy gap at the point Γ depends on the composition, varying from 1.66 eV for CdTe to 0.330 for HgTe [1]. For the compositions with small x and at low temperatures the mobility of carriers may amount to $10^6\text{ cm}^2\text{ V, s}$, their life-time is short, ranging within 10^{-8} – 10^{-10} s [2]. For this reason the $\text{Cd}_x\text{Hg}_{1-x}\text{Te}$ with x close to 0.15 may be used for detecting infrared radiation within a wide range of wavelength.

A volume PV effect has been examined in $\text{Cd}_x\text{Hg}_{1-x}\text{Te}$ for $0.07 < x < 0.16$ [3]. Maximum sensitivity at room temperature amounted to 0.3 V/W for light modulation frequency equal to 10 Hz . It has been stated that the PV effect highly dominated over the PEM (in the presence of field $0.5\text{ (V}\cdot\text{s/m}^2)$) and PC effects.

In paper [4] a production of p - n junctions by annealing the $\text{Cd}_x\text{Hg}_{1-x}\text{Te}$ crystals of p -type in the mercury vapour atmosphere at temperature 573 K for 3 hrs was reported. Both current-voltage and capacitance-voltage characteristics of the p - n junctions produced in this way were examined and the value of cut-off voltage at 77 K was determined as ranging from 0.3 V to 0.35 V . Spectral dependence of photoelectric voltage was also investigated but no detailed numerical data were presented.

This paper presents the results obtained from spectral sensitivity measurements of photovoltaic effect in p - n junctions produced by annealing the $\text{Cd}_{0.2}\text{Hg}_{0.8}\text{Te}$ crystal of p -type in mercury atmosphere.

2. Experimental Part

a) Preparation of Samples

The p - n junctions have been produced in $\text{Cd}_{0.2}\text{Hg}_{0.8}\text{Te}$ monocrystals of the p -type, have been obtained from the Institute of Physics of Polish Academy of Sciences in Warsaw, owing to the courtesy of Docent W. Gariat. The crystals were cut into cuboid ($6\times 2\times 0.5\times \text{m}$) mm^3 plates by means of an electro-erosion device, then polished mechanically and etched in 5% methanolic solution of Br . The transfer in conductivity type at the surface layer from p -type to n -type was obtained by annealing the p -type material at the mercury atmosphere within the temperatures range 460 – 550 K for several minutes to several hours. The doping process in mercury vapours has been described in details in [5]. The thickness of the n -type layers produced in this way ranged from the fractions of μm to several μm , depending on the time and temperature of annealing. Both thickness and conductivity of the layer have been determined by a thermocouple probe applied to an oblique (1.5°) microsection. The thickness accuracy measurement has been estimated to be not worse than 5% . Within the n -type region the surface carrier concentration determined at 300 K by Hall coefficient and conductivity measurements ranged from 1×10^{17} to $8\times 10^{17}\text{ cm}^{-3}$. Ohmic contacts have been fitted experimentally in the way described in [6]. In this work the contacts were made by vacuum deposition of gold and indium layers on the p and n regions, respectively. The geometry of the p - n junctions with contacts adjusted to the measurements of both current-voltage characteristics and photovoltaic effect is presented in Fig. 1.

* Institute of Technical Physics, Technical University of Wrocław, Wrocław, Wybrzeże Wyspiańskiego 27, Poland.

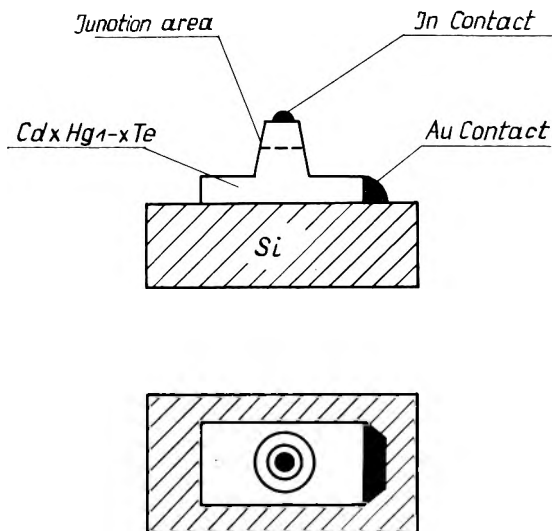

Fig. 1. Geometry of the $p-n$ junctions under test

b) Measuring System

A block scheme of the measuring system for the photovoltaic effect is shown in Fig. 2. The modulated radiation, being passed from the source through a monochromator, is directed either on to the element under investigation or on to the reference detector. As the source of radiation a SiC bar heated to about 1600 K was used; this allowed to take the measurements within 1 μm to 15 μm wavelength range. A mechanical modulator with a stabilized frequency 10 Hz has been applied to cooperate with a vacuum VTh-1 thermoelement supplied with KRS-5 window, its sensitivity being 6.1 V/W, time constant 45 ms. Photoelectric voltage was measured with a (UNIPAN-203) selective microvoltmeter with a preamplifier.

3. Discussion of Results

Spectral characteristics of the absolute sensitivity of the PV effect, exemplified by 2 selected

X-1003 and X-1057 $p-n$ junctions are presented in Fig. 3. Spectral distributions of the remaining junctions resembled in shape and only slightly differed in absolute sensitivity value. The maximum sensitivity values, amounting to about 2 V/W have been obtained at 77 K for the wavelength 5.6 μm ,

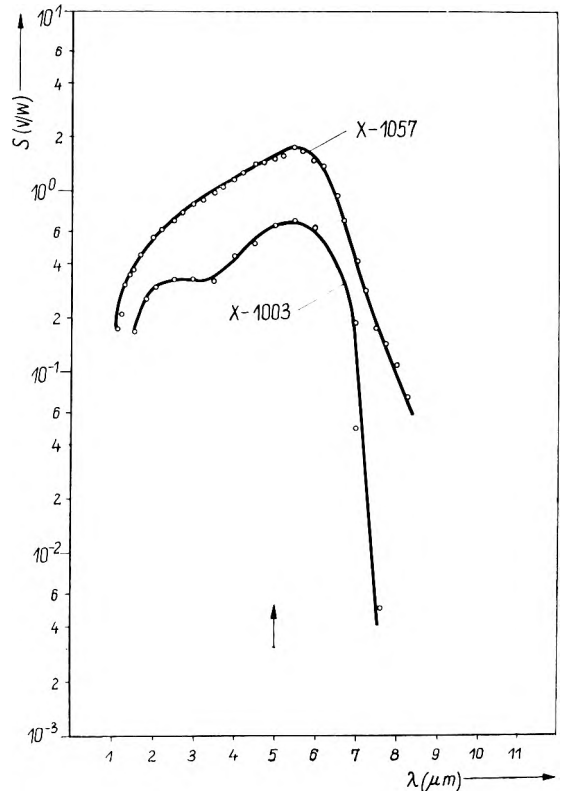

Fig. 3. Spectral dependence of the photovoltaic effect at the temperature 77 K for two $p-n$ junctions in $\text{Cd}_x\text{Hg}_{1-x}\text{Te}$. The maximum of the characteristics for X-1057 junction at 300 K (temperature) is denoted by an arrow

i.e. for the energy of a single quantum equal to about 0.22 eV. These values, however, should be treated as underestimated ones. This is due to the fact that since an accurate estimation of the working detector area is difficult the total value of the junction area in the direction perpendicular to the incident ra-

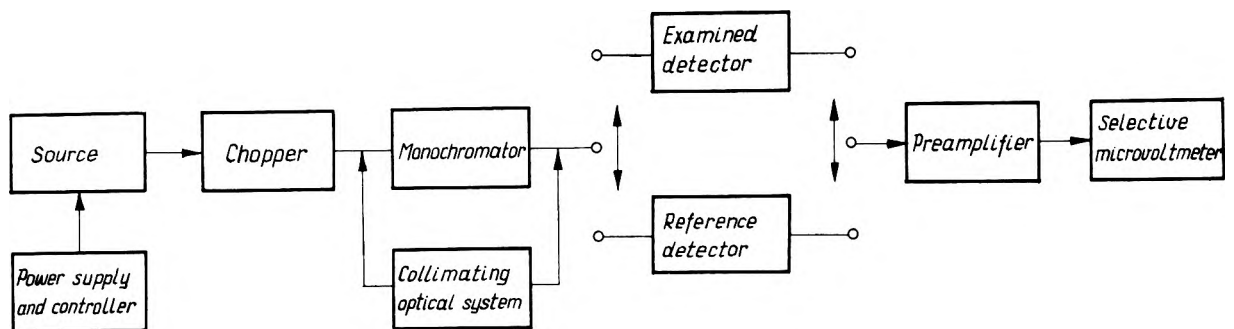

Fig. 2. Block diagram of the measuring system for the photovoltaic effect examination

diation was taken for calculations, while only certain part of it was exploited in reality, in the course of measurements.

At temperature raised to 300 K the magnitude of the signal was about two orders of magnitudes lower, the maximum of characteristic being at the same time shifted to $5 \mu\text{m}$ thus to a higher energy (0.25 eV). From the above results it may be inferred that the effect observed on p - n junction was really of photovoltaic (PV) type and not a volume (PV) effect the latter being associated with heterogeneity of the material that often occurs in $\text{Cd}_x\text{Hg}_{1-x}\text{Te}$ [7]. As shown in [3] the volume PV effect seems to be associated rather with a rise of signal value by about two orders of magnitude when changing the temperature from 77 K to 300 K.

An additional argument in favour of existence of the PV effect in the junction are the results of electric measurements [8], made in our laboratory. In Fig. 4 a current-voltage characteristics is shown for one of the junctions under test taken at the tem-

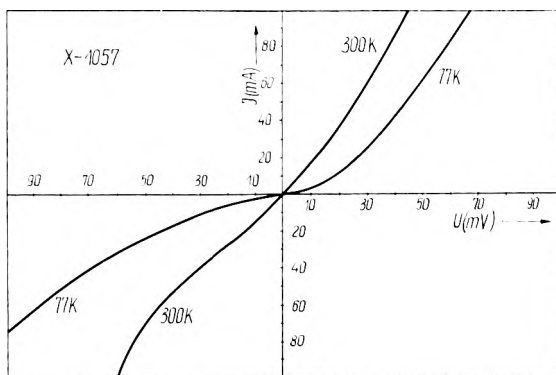

Fig. 4. Current-voltage characteristics of an X-1057 junction at the temperatures 77 K and 300 K, respectively

peratures 77 K and 300 K, respectively. At the 300 K temperature the characteristics is almost linear, while the deviations from linearity appearing at its ends may be associated — in our opinion — with the effect of rise of the sample temperature during the measurement. At 77 K, at which the average energy of carriers is lower, the effect is distinctly marked, proving the existence of p - n junctions.

A shift in the maximum sensitivity of PV effect toward short waves which occurs when rising the temperature, may be associated with a change in the energy gap in $\text{Cd}_x\text{Hg}_{1-x}\text{Te}$. For the compositions with $x < 0.4$ the coefficient is positive [9]. We have stated a qualitative consistency between the observed shift in the maximum of PV effect and the temperature changes of ΔE_g described in [9].

For the junctions tested the estimated maximum detectivity D^* is equal to $10^7 \text{ W}^{-1} \times \text{cm} \times \text{Hz}^{1/2}$ approximately. It should be emphasized that the detectivity has been limited by noises produced by measuring system rather than by the detector.

The fact that the detectivity value estimated by us is less than those given in the literature (order of 10^9 – 10^{10}) is probably caused also by the low amplitude modulation frequency $f = 10 \text{ Hz}$ applied in our experiments (independently of electronic system noise). Such modulation frequency is too low for phonon detectors as it was shown in paper [10], but we were forced to use it to match the time constant of the reference detector used in our measurements.

*
* * *

The authors express their best thanks to Doc. Dr. W. GIRIAT for helpful discussion and providing the samples of $\text{Cd}_x\text{Hg}_{1-x}\text{Te}$.

Sélectivité spectrale de l'effet photovoltaïque dans les connecteurs p - n dans le $\text{Cd}_{0,2}\text{Hg}_{0,8}\text{Te}$

On a effectué, dans un monocristal de $\text{Cd}_{0,2}\text{Hg}_{0,8}\text{Te}$ du type p , les connecteurs p - n par traitement isotherme sous atmosphère de mercure. Le caractéristiques spectrales de l'effet photovoltaïque ont été mesurées dans ces connecteurs entre $1 \mu\text{m}$ et $15 \mu\text{m}$. On a déterminé la sensibilité maximale $S_{\text{max}} = 2 \text{ V/W}$ à la température de 77 K pour une longueur d'onde $5,5 \mu\text{m}$.

Спектральная избирательность фотовольтаического эффекта в соединениях p - n в $\text{Cd}_{0,2}\text{Hg}_{0,8}\text{Te}$

Изготовлены соединения p - n в монокристалле $\text{Cd}_{0,2}\text{Hg}_{0,8}\text{Te}$ типа p путем выдержки в атмосфере ртути. Измерен спектр характеристичности фотовольтаического эффекта в этих соединениях, в области от $1 \mu\text{m}$ до $15 \mu\text{m}$. Определена максимальная избирательность $S_{\text{max}} = 2 \text{ В/ватт}$ при температуре 77 K для волны $5,6 \mu\text{m}$.

References

- [1] SCOTT M. W., Jour. Appl. Phys. **40**, 4077 (1969).
- [2] COHEN-SOLAL, G. MARFAING Y., KAMANDIEV P., Proc. Intern. Conf. Phys. II-VI Semicond. Providence, USA, ed. W. A. Benjamin, New York 1967.
- [3] BARANOWSKI J., MYCIELSKI A., *Nowoczesne materiały i przyrządy półprzewodnikowe*, PWN, Warszawa 1972.
- [4] FIGUROVSKIY E. N., KIREYEV J. C., VANUKOV A. V., JEVSEYEV U. V., Fiz. Techn. Poluprov. **3**, 1857 (1969).
- [5] BECLA P., DZIEDZIC J., PAWLIKOWSKI J. M., PYKACZ H., MRÓZ J., Prace IFT Pol. Wrocł. (in press).
- [6] BECLA P., PAWLIKOWSKI J. M., PYKACZ H., Proc. IV

- Związków Półprzewodnikowych, Jaszowiec 1973, IF
PAN Report, **48**, 167 (1974).
- [7] GALĄZKA R. R., SOSNOWSKI L., Phys. Stat. **20**, 113 (1967).
[8] BECLA P., PAWLIKOWSKI J. M., (in press).
[9] GIRIAT W., Postępy Fizyki **XXI**, 591 (1970).
[10] HUDSON R. D., Infrared System Engin., New York 1969.

Received, January 31, 1974.