

A Simple Method of the Coherent and Incoherent MTF Visualization

Simple visual experiments to serving as demonstrations during the lecture on optics, and concerning the contrast transfer function of optical systems operating under different conditions of illuminating field coherence have been described. The schemes of arrangements used to obtain test images being illuminated by a model of light source with gradually altered coherence degree are presented. The pictures of test images illustrate quantitatively the MTF course of both non-aberrated and aberrated optical systems under different illumination conditions.

Simple visual experiments to illustrate a specialized lecture on optics and concerning contrast transfer function of optical systems operating under different conditions of illuminating field coherence have been described. The arrangement used to obtain images of tests illuminated by a model of light source with the coherence degree altered gradually, have been presented schematically. The pictures of test images illustrate qualitatively the MTF course of optical systems, both aberrated and non-aberrated, under different illumination conditions.

1. Introduction

It is well known that imaging quality of a lens, can be characterized by Optical Transfer Function or its modulus — Modulation Transfer Function (MTF). Complete MTF measurement is being time-consuming and requiring specialized instruments, is too complicated to be widely used for teaching purposes especially for demonstrations performed during the lecture.

For such purely illustrative purposes it is quite enough to evaluate the MTF from the contrast degradation in an image of a periodic test.

Hereafter some simple experiments based on such method and illustrating the MTF of a "perfect" optical system as well as the MTF of an "aberrated" system under different coherence conditions of illuminating light are described.

A typical achromatic cemented doublet lens of $f = 165$ mm is used as a model of imaging system under investigation. Spatial frequencies in the used tests are of the same order that the coherent and incoherent cut-off frequencies computed from the lens aperture.

Under such conditions the influence of diffraction on the image is comparable or even more significant than the deformation of the image caused by aberrations. The imaging system is treated as a model of an "aberration free optical system".

For the same reason a model of an "aberrated system" must be characterized by substantial aberrations. This is done defocusing the lens described above.

2. Illuminating system

The illuminating system (Figs. 1,2) gives a collimated, quasi-monochromatic light beam, whose degree of coherence is controllable by the experimenter.

High pressure mercury lamp (of HBO-200 type) is used as a source of light (1). Electrical discharge region is imaged onto a pinhole (3) by a short-focus lens (2). An interference filter (4) ensures quasi-monochromacy. Light passing through the pinhole (of diameter about $0.25 \mu\text{m}$) is focused by the next lens (5) onto a ground-glass screen (6) and forms there a light spot, which operates as a secondary light source. If the image of the pinhole sharp, then the

* Institute of Technical Physics, Wrocław Technical University, Poland.

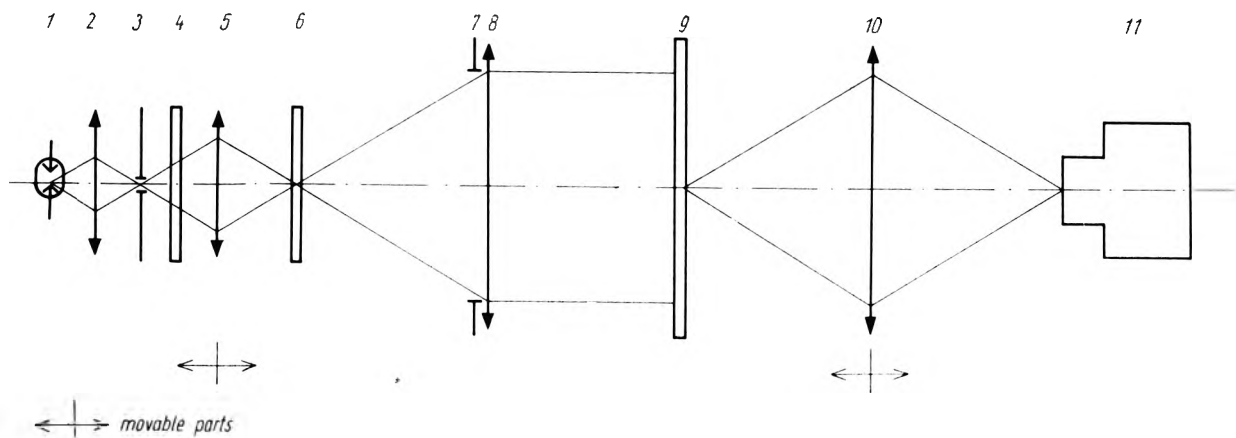

Fig. 1. Diagram of the optical system (description in text)

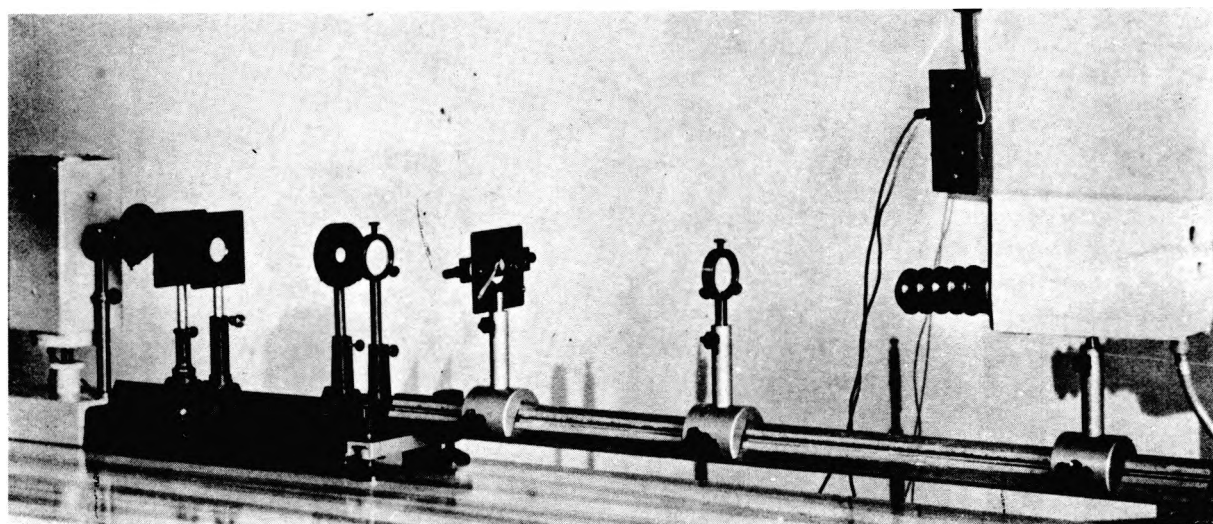

Fig. 2. Optical system

diameter of this spot is the smallest one and nearly to the pinhole diameter (magnification of this part of the system is about 1). By defocusing the lens (5) the experimenter may magnify the diameter of the light spot.

Since the mercury lamp is a thermal source it may be considered as incoherent, and consequently its image on the ground glass (6) (the secondary light source) may be assumed to be incoherent too. Moreover, the secondary light source may be treated as a flat and homogeneous radiator. According to the Van Cittert-Zernicke theorem a change in the source dimension causes a respective change of degree of coherence in the generated light field [1].

For the numerical evaluation of the degree of coherence behind the collimator let us assume that the formula:

$$|\gamma_{1,2}(0)| = \frac{2J_1(k \cdot r_{1,2} \cdot a/R)}{k \cdot r_{1,2} \cdot a/R}$$

is valid under described conditions, where a/R is angular diameter of the secondary light source (6) as seen from the centre of the collimating lens,

$$k = 2\pi/\lambda,$$

$r_{1,2}$ is the distance between two considered points in the space behind the collimator,

$J_1(x)$ is the Bessel function of first kind and first order.

The minimum diameter of the secondary light source (6) is a_{\min}

$$a_{\min} \approx 0.25 \text{ mm}, R = 165 \text{ mm},$$

$$k = 2\pi/546 \text{ mm}$$

hence,

$$|\gamma_{1,2}(0)| \approx 0.8, \text{ when } r_{1,2} = 0.75 \text{ mm}.$$

This means that when an object under observation contains details not greater than $r_{1,2}$ (spatial frequency $f \geq 1/r_{1,2}$) then the light field can be considered as nearly coherent.

Due to magnification of the diameter of the secondary light source (6) up to $a_{\max} = 2 \text{ mm}$

the degree of coherence decreases for the same $r_{1,2}$ down to $|\gamma_{1,2}(0)| \approx 0.08$. Even for $r_{1,2} = 0.2$ mm the value of $|\gamma_{1,2}(0)|$ does not exceed 0.3.

This means that the light behind the collimator may be considered as nearly incoherent even in case when the observed details are as small as 0.2 mm.

Thus the light beam behind the collimating lens (8) can be changed by the experimenter from near coherent to near incoherent (to the approximation sufficient for demonstration purposes) by moving the lens (5) back and forth along an optical axis.

3. Coherent and incoherent MTF of diffraction limited lens

3.1. Test

A radial test (Fig. 3) of $N = 106$ sectors is used as an object. Spatial frequency distribution has radial symmetry.

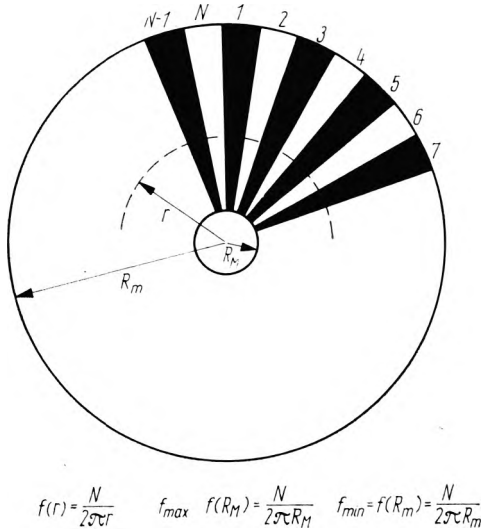

Fig. 3. Radial test

With a good approximation it can be assumed that main spatial frequency f is a function of the distance r from the centre of the test

$$f(r) = \frac{1}{2} \frac{N}{\pi r}$$

It can be also assumed, that such a test contains all spatial frequencies closed in the interval (f_{\min}, f_{\max}) . The limiting frequencies f_{\min} and f_{\max} result from the geometry of the test and technology of its production (see Fig. 3) and are about 1 mm^{-1} and 70 mm^{-1} , respectively.

3.2. Imaging system

The test (9) illuminated as described above is imaged by a lens (10) — Fig. 1. The image is observed on a screen or by means of a TV camera.

The imaging lens (10) has a coherent cut-off frequency higher than f_{\max} (say $f_{\text{grA}}^{\text{COH}}$), however, can be decreased by diminishing the diameter of the entrance pupil of the lens. This can be done by using a variable diaphragm (7) not shown in the photograph — Fig. 2. By “shutting” the diaphragm the cut-off frequency decreases and is equal to $f_{\text{grB}}^{\text{COH}}$ when the diameter of the diaphragm is the minimum. This frequency is lower than f_{\max} .

Let us denote the corresponding incoherent cut-off frequencies by $f_{\text{grA}}^{\text{INCOH}}$ and $f_{\text{grB}}^{\text{INCOH}}$ respectively. In view of the known relationship: $f_{\text{gr}}^{\text{INCOH}} = 2 \cdot f_{\text{gr}}^{\text{COH}}$ both incoherent cut-off frequencies may be made greater than f_{\max} .

As it has been explained before in each case mentioned above the imaging lens (10) may be considered to be diffraction limited.

3.3. Experiment

The images of the test given by a lens (10) when the diaphragm (7) is fully open (high f_{grA}) as well as when its diameter is the smallest (low f_{grB}) are observed consecutively. Light beam produced by illuminating system from nearly coherent to nearly incoherent one.

Photographs 4a and 5a show the images given by a lens with high (f_{grA}) under nearly coherent and nearly incoherent illumination, respectively.

From Fig. 4a it can be easily seen that all spatial frequencies of the test are transmitted correctly. The contrast of all frequencies up to f_{\max} is high and almost the same as in the test under coherent illumination. Hence, for all the frequencies used in the test the value of MTF is almost 1.

In case of incoherent illumination (Fig. 5a) the contrast in the image decreases uniformly from the external part of the test towards its center, i.e. from lower to higher frequencies. It shows that the value of MTF decrease with the increasing spatial frequency.

Photograph 4b shows the coherent image given by a lens when its cut-off frequency is low ($f_{\text{grB}}^{\text{COH}}$). The black center of the imaged

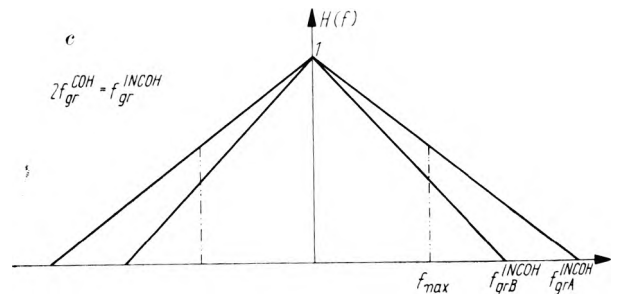
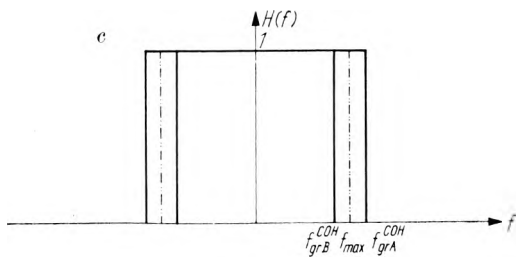
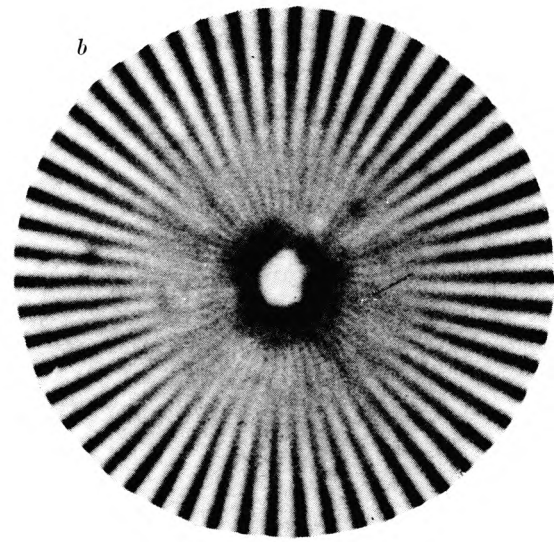
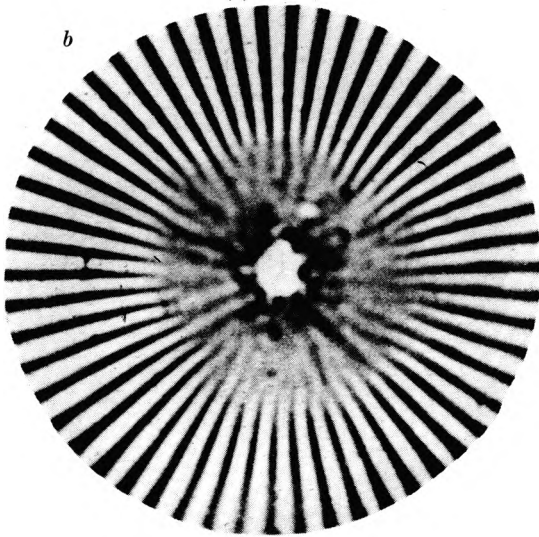
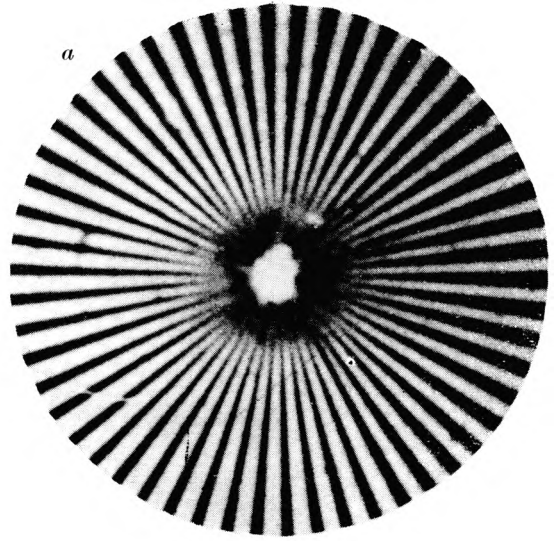
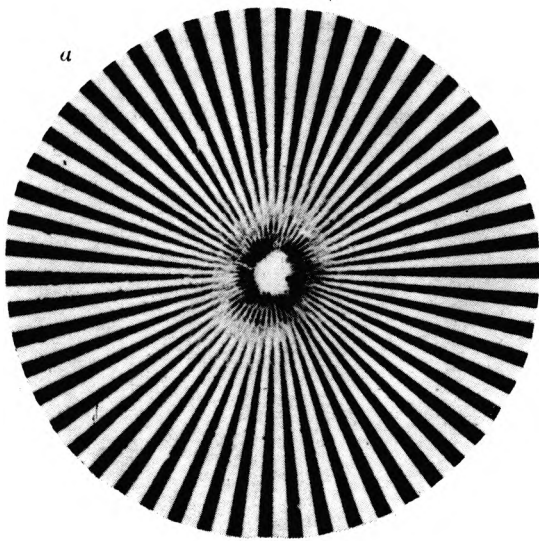

Fig. 4. Nearly coherent illumination
 a) image of the test – high f_{grA}^{COH} , b) image of the test – low f_{grB}^{COH} , c) MTF curves

Fig. 5. Nearly incoherent illumination
 a) image of the test – high f_{grA}^{INCOH} , b) image of the test – low f_{grB}^{INCOH} , c) MTF curves

test means that high frequencies are not transferred at all. This proves that the coherent MTF curve is of rectangular shape.

On the other hand, the incoherent image (Fig. 5b) under the same imaging geometry shows that all the frequencies are transferred the contrast, however, gradually decreases towards the center of test image (cf. Fig. 5a).

4. Influence of aberrations on coherent and incoherent MTF

4.1. Imaging system and test

The test is the same as before. The same lens (10) is used for imaging. The diaphragm is "fully open". Both coherent and incoherent cut-off frequencies are high.

4.2. Experiment

The purpose of demonstration is to defocus the imaging lens (10) and to observe the changed image of the test. Defocusing is equivalent to introduction of aberrations into the imaging system as it was explained before. The observations are done in nearly coherent (Figs. 6a, 6b) and nearly incoherent (Figs. 7a, 7b) illumination.

"Diffraction limited" images shown in Figs. 6a and 6b are given for comparative reasons. Figures 6b and 7b show the images of the test given by an "aberrated lens". The hypothetical MTF curves of aberrated lens are shown in Figures 6c and 7c.

It can be seen that for both coherent and incoherent illuminations low spatial frequencies (external part of the test's image marked A) are transmitted with a slightly decreased contrast. Thus it may be inferred that for low frequencies the MTF value is lower than 1. There are also some frequencies which are not imaged at all (region B in the image), in this case the value of MTF is equal to zero. For some frequencies MTF has negative values. This corresponds to the areas of reversed contrast in the image (C).

Zeros of the MTF curve can be evaluated from the radii of consecutive regions B

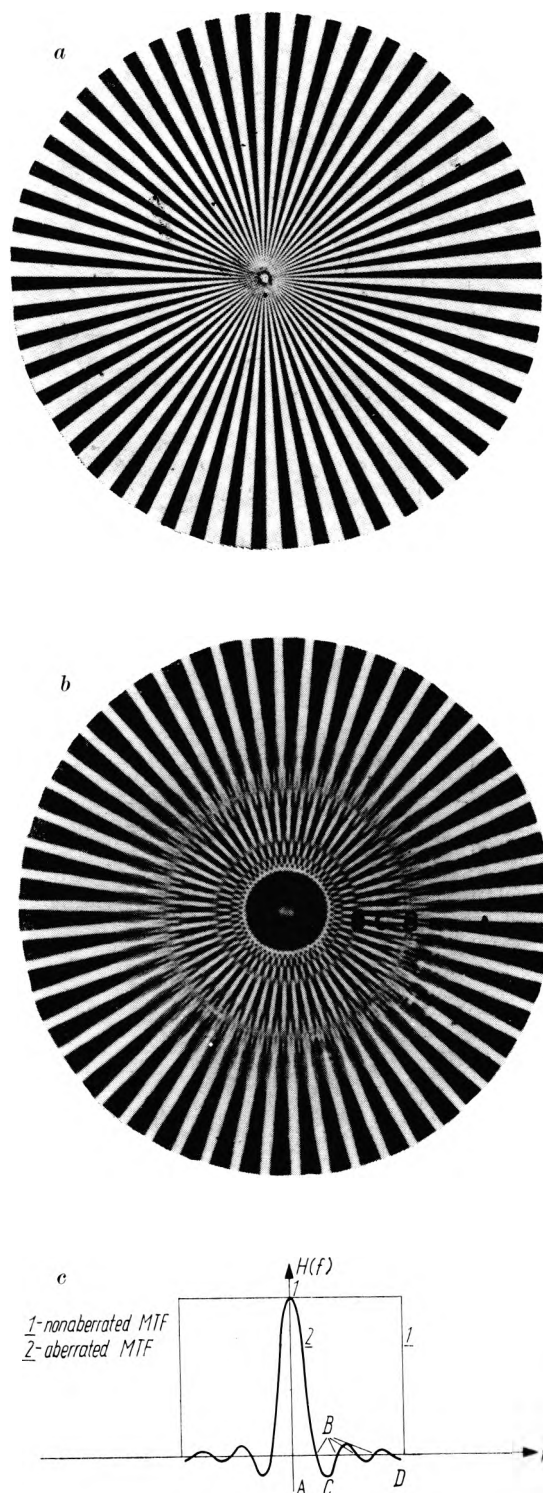

Fig. 6. Nearly coherent illumination
a) non-aberrated image of the test, b) aberrated image of the test, c) MTF curves

in the test image. The data measured in Fig. 6b are given as an example:

Relative radii of consecutive regions of the contrast vanish:

$$r_1 : r_2 : r_3 : r_4 = 69 : 41 : 30 : 24.$$

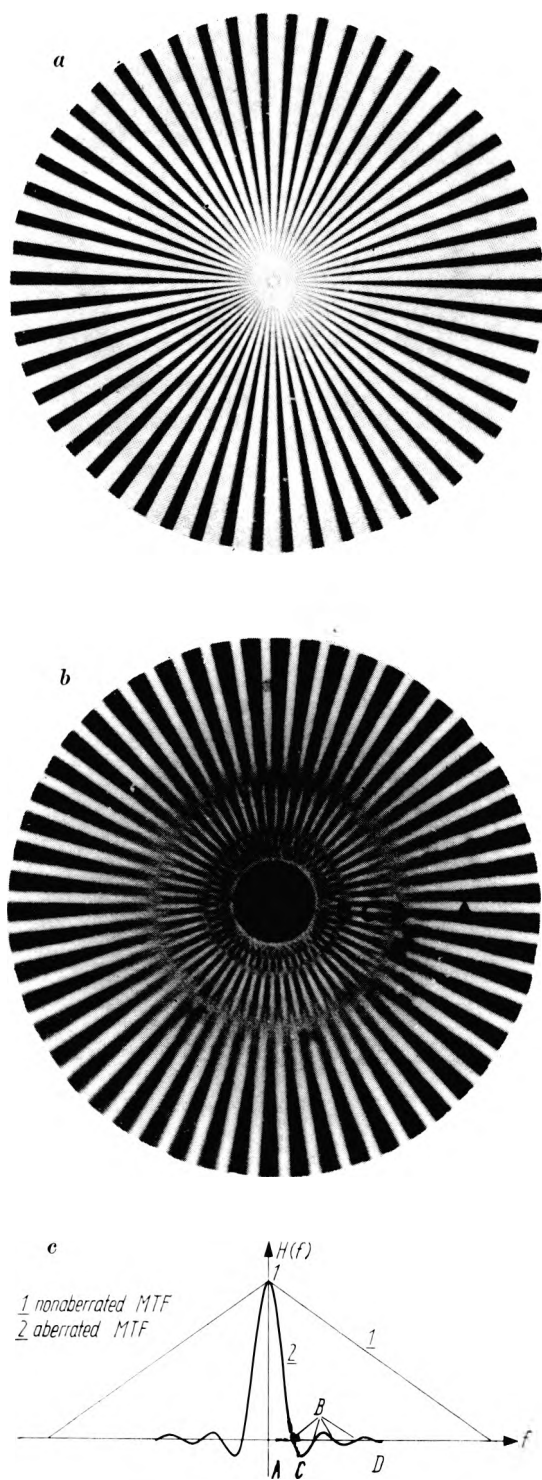

Fig. 7. Nearly incoherent illumination
a) non-aberrated image of the test, b) aberrated image of the test, c) MTF curves

Relative frequencies of 4 consecutive zeros of MTF are the following:

$$f_1 : f_2 : f_3 : f_4 = \frac{1}{r_1} : \frac{1}{r_2} : \frac{1}{r_3} : \frac{1}{r_4} = 4.2 : 7.0 : 9.6 : 12.0.$$

Zeros are approximately equally spaced with in the frequency domain.

For the incoherent illumination the values of MTF becomes are equal to zero in the same points (Fig. 7b) but in general MTF has smaller values than for coherent case (contrast in the image is lower).

5. Influence of degree of coherence on MTF

5.1. Imaging system and test

The imaging system is a little more complicated than in previous case (Fig. 8). It consists of 2 identical lenses arranged in such way, that the image of a test given by the whole system (10-11), and the Fourier spectrum of the test given by the first lens (10) can be observed simultaneously. A Ronchi ruling (9) is applied as a test-object. The imaging system (10-11) has a little higher incoherent cut-off frequency than spatial frequency of the test, but its coherent cut-off frequency is greater

$$f_{gr}^{COH} < f_{test} < f_{gr}^{INCOH}.$$

For the same reasons as in previous experiment the lens may be considered to be diffraction limited.

The image of the test is observed by a TV camera (13).

The Fourier plane of the lens (10) is imaged onto a half-transparent screen (16) by means of an other lens (15) and a prism beamsplitter (14) and observed by a second TV camera (18).

5.2. Experiment

Intensity distribution in the Fourier plane (12) of a optical system depends on the degree of coherence of illuminating light. In coherent case this distribution is proportional to the Fourier spectrum of a test transmittance squared. With the decreasing degree of coherence the Fourier spectrum obliterates. This fact is used for qualitative evaluation of the coherence state.

The idea of demonstration is based on simultaneous observation of both intensity distribution in the Fourier plane (considered as an evaluation of the degree of coherence)

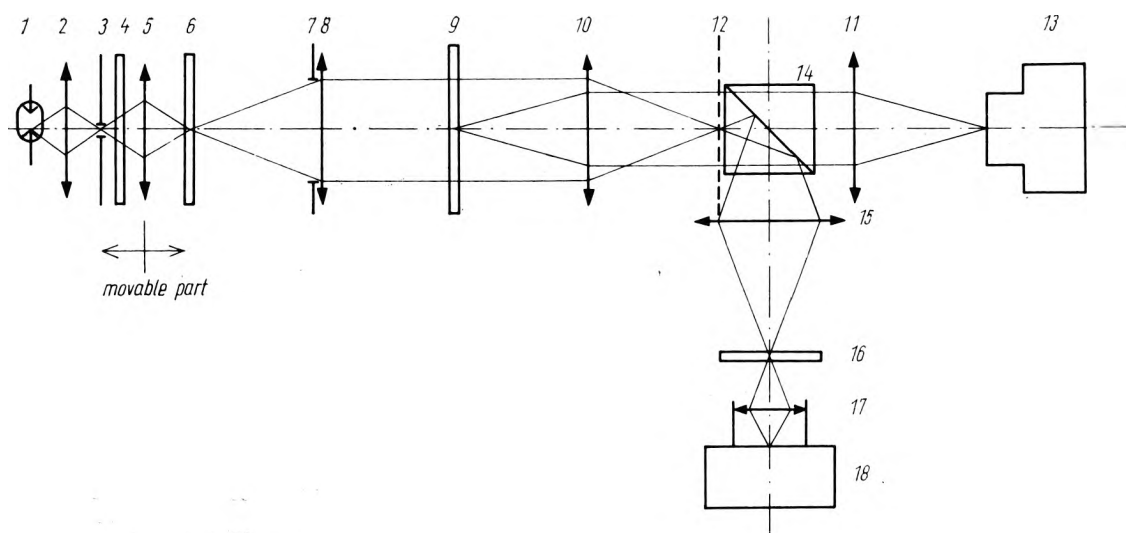

Fig. 8. Diagram of the optical system (description in text)

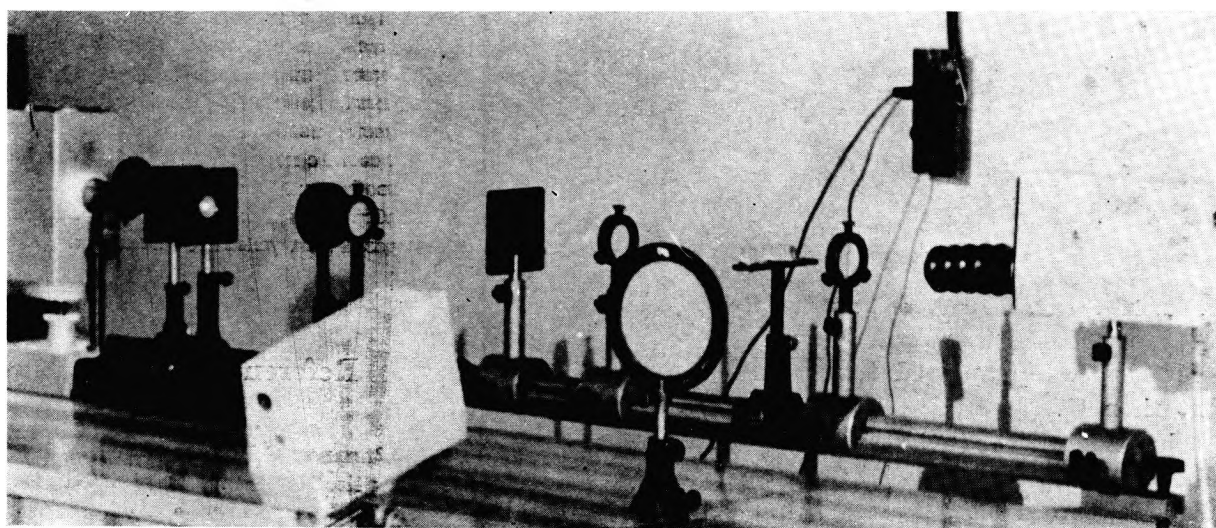

Fig. 9. Optical system

and a focused image of a test. The state of coherence of illuminating light is changed by the experimenter, as it was described before, from near perfect coherence to near incoherence. In Figures 10 and 11 the images of the tests and its Fourier spectrum for two different states of coherence are shown. It can be easily seen that the quality of the image (i.e. its contrast) decreases with the decreasing degree of coherence.

Approximate shapes of MTF curves are shown in Fig. 12.

6. Remarks

In view of only qualitative and illustrative character of the demonstrations described, both coherent and incoherent MTF-s — despite

the differences in their physical interpretation — may be considered simultaneously.

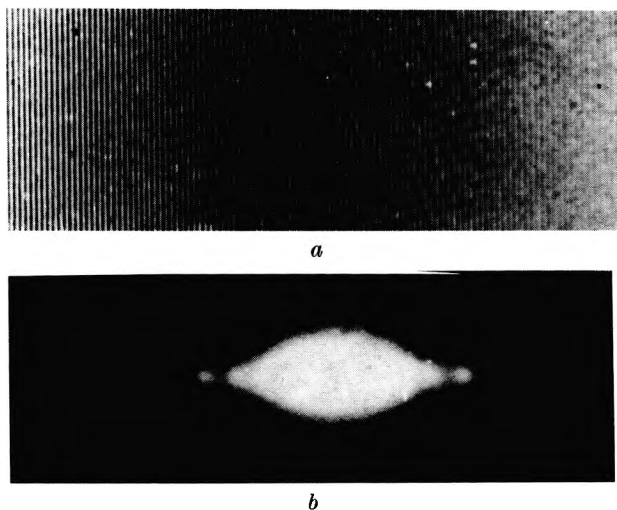

Fig. 10. Nearly coherent illumination
a) image of the test, b) Fourier spectrum of test

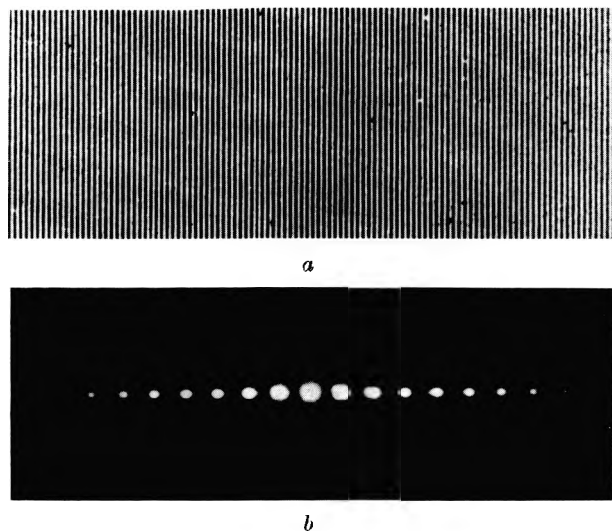

Fig. 11. Nearly incoherent illumination
a) image of the test, b) Fourier spectrum of the test

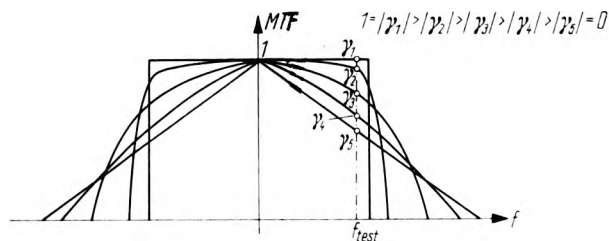

Fig. 12. MTF curves for different states of coherence

Mercury lamp appeared to be more convenient than CW laser, because it can be used as coherent as well as incoherent light source, and it does not cause specking effect.

The above demonstrations were designed and performed to illustrate the lecture on Coherent Optics held by Doc. I. Wilk for the students of the Institute of Physics of the Technical University of Wrocław.

Une simple méthode de visualisation MTF cohérente et incohérente

On a décrit de simples expériences de démonstration destinées à illustrer un cours spécial de l'optique et concernant la Fonction du Transfert de Contrast des systèmes optiques fonctionnant en conditions différentes de cohérence du champ éclairant. On présente également des schémas des systèmes de démonstration permettant d'obtenir les images des tests éclairés par un modèle de la source de lumière aux variables niveaux de cohérence. Les photographies des images des tests démontrent l'allure MTF des systèmes optiques à aberration et sans aberration dans des conditions d'éclairage différentes.

Простой метод представления когерентной и некогерентной функции переноса контраста

В работе описаны простые показательные опыты, предназначенные для иллюстрирования специальной лекции по оптике, касающиеся Функции Переноса Контраста оптических систем, работающих в различных условиях когеренции освещающего поля. Приведены схемы демонстрационных систем для получения изображений тестов, освещаемых моделью источника света с переменной степенью когеренции. Фотоснимки изображений тестов качественно иллюстрируют как безабберационных, так и абберационных оптических схем в различных условиях освещения.

References

- [1] BERAN M.J., PARRENT G.B. Jr., *Theory of Partial Coherence*, Prentice Hall Inc. Englewood Cliffs.
- [2] GOODMAN J.W., *Introduction to Fourier Optics*, McGraw Hill Book Comp. 1968.
- [e] SOROKO L.M., *Osnovy golografii i kogerentnoy optiki*, Izd. Nauka, Moskva 1973 (in Russian).

Received, February 8, 1975