

Design and construction of a microcomputer based interface/controller to drive and process spectrophotometer data

Y. A. YOUSEF

Chemistry Department, Yarmouk University, Irbid, Jordan.

M. M. SHADERMA, L. H. ABU-HASSAN, A. J. ABU EL-HAJA *

Physics Department, University of Jordan, Amman, Jordan.

A. A. ROUSAN *

Physics Department, University of Science and Technology, Irbid, Jordan.

In this work, we report a computer-based design and construction of a spectrophotometer interface and controller system. The entire design both in hardware and software was intended to replace the microdrive and chart recorder units with the old McPherson model 2061 monochromator. Unlike the old system, the new system proved to be much more practical and flexible since it is made programmable to store, manipulate and plot data produced by the spectrophotometer. For illustration purposes an example is presented.

1. Introduction

Spectrophotometers serve as efficient tools for the study of physical and chemical properties of materials. However, the cost of such systems is, in general, rather high, especially of the computerized units, and their service is normally expensive since the repair and supply of spare parts by the manufacturer are custom designed for their systems. For example, the EPROM (Erasable Programmable Read Only Memory) which contains the operating software for particular microdrive units used with certain monochromators in some cases has certain life time [1], [2]. The cost of replacing the EPROM is normally very high and sometimes the manufacturer may stop production of certain parts when they become out of date. Therefore, a local design and manufacturing of a particular unit as part of the whole system, if possible, make the trouble-shooting and servicing much easier and less time consuming. Accordingly, a design and construction of a microcomputer based interface/controller to drive and process spectrophotometer data was carried out. The cost of the constructed system including 486-PC, IBM compatible microcomputer and laser printer was found to be much less than that of the standard commercial driving unit alone, assuming that it has to be ordered from the original

* Presently at Al Al-Bayt University Mafraq, Jordan, on leave from their institutions.

manufacturer. Moreover, the possibility of modifying the proposed system remains at hand, since changing the type of experiments and modifying the measurements under investigation can be easily carried out.

2. System description

2.1. Hardware

The system consists of two main parts: monochromator drive unit and data logger and controller unit. Both parts were designed and constructed locally.

2.1.1. Monochromator

The monochromator drive unit controls the operation of the monochromator, *i.e.*, it rotates the stepper motor into the clockwise or counterclockwise direction, depending on the option of increasing or decreasing the wavelength scale. A complete motor revolution corresponds to 200 steps [1], *i.e.*, 200 pulses are required to rotate the motor one complete revolution. For the 1200 grooves/mm grating, the 200 steps correspond to 50 Å [2]; therefore, it is possible to scan the monochromator in steps of 0.25 Å.

The stepper motor can be rotated by sending series of pulses to 4 coils contained in the motor housing. The coils are driven by a set of 4 transistors that are used as a current amplifier to drive the motor coils [3]. The current amplifier transistors were mounted on an efficient heat sink to dissipate the heat generated by the transistors resulting from switching during the power conversion process. The diodes were used to eliminate the free running currents into the motor coils.

2.1.2. Data logger and controller

The data logger device is designed to be plugged into the RS 232 PC port. It is built around a standard USRT (Universal Synchronous Receiver Transmitter) and a

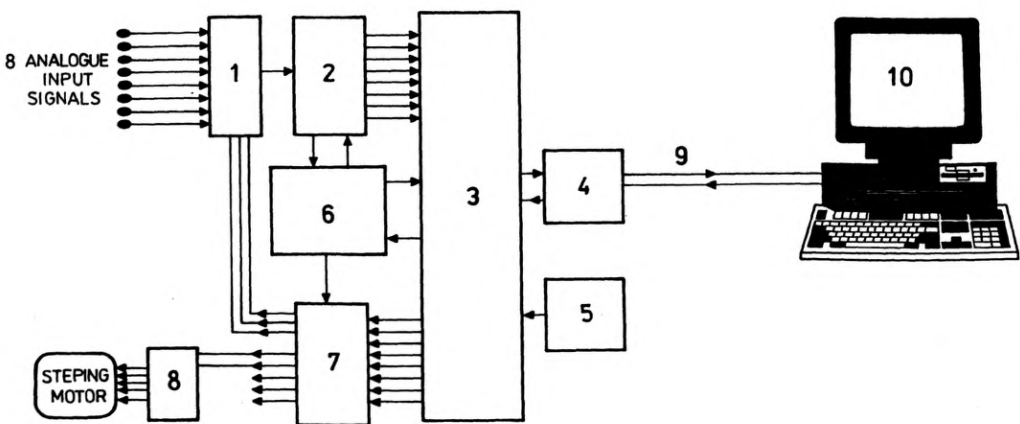

Fig. 1. Schematic of the automation unit: 1 – analogue multiplexer, 2 – ADC, 3 – UART, 4 – RS 232 interface, 5 – baud rate generator, 6 – timing circuit, 7 – octal latch, 8 – stepping motor driver, 9 – three wire RS 232 cable, 10 – computer system

12-bit ADC (Analog to Digital Converter). The baud rate is set to 4800 bit/s which is convenient for this purpose.

The device has 8 input parts that can be selected randomly as shown in Fig. 1. The level of the input signal is in the range of -5 to $+5$ V. The output signal from the PMT (Photomultiplier Tube, model R928 from Hamamatsu) is connected to one of these ports. The device has 5 digital output lines, each used to control an individual device by turning it ON or OFF. Two of the output lines are allocated for the stepper motor drive mentioned above.

Since the ADC has only 12 bits, the quantization error becomes intolerable when the input signal is low. This can be overcome by repeating the reading of the same point for at least 10 times and calculating the average value. The output of the PMT in our work was in the millivolt range. A low-noise high-gain amplifier was designed and linked to the data acquisition system.

2.2. Software

The designed software can be divided into the following three main programs: a program responsible for moving the monochromator from one wavelength to another, a program for scanning the spectrum, and the third program for data manipulation. These programs were written in Turbo Basic language [4] and were easily linked with each other.

The flow chart describing the whole program for moving the monochromator and scanning the spectrum is shown in Fig. 2. The program calculates the required wavelength range by subtracting the target wavelength from the current monochromator reading and multiplying the result by a factor of 4 to convert the wavelength scale into motor steps as described in the hardware section (2.1). This program is used to move the monochromator from one wavelength to another and also to calibrate the computer wavelength reading with the mechanical counter reading.

The program is designed to offer the user a wide flexibility in scanning different types of spectra. The resolution can be selected by changing the spacing between the data points, *i.e.*, decreasing the spacing between the data points increases the resolution and vice versa.

The sensitivity of the detector is made liable for adjustment through increasing the number of samples which enables the user to acquire very weak light intensities without increasing the width of the monochromator slits; this helps keep the monochromator resolution unchanged.

The program converts the digitized light intensity signal into an ASCII code decimal number and stores it into a data file along with its corresponding wavelength in Angstroms. The data file will be in the form of a two-dimensional matrix containing the wavelength in one column and its corresponding light intensity in the other.

Data manipulation is made simple by using the commercial type graphics software. As an example, we have used the AXUM software which enables the user to perform mathematical operations on the data files as well as plotting the data files in normal or Log scales.

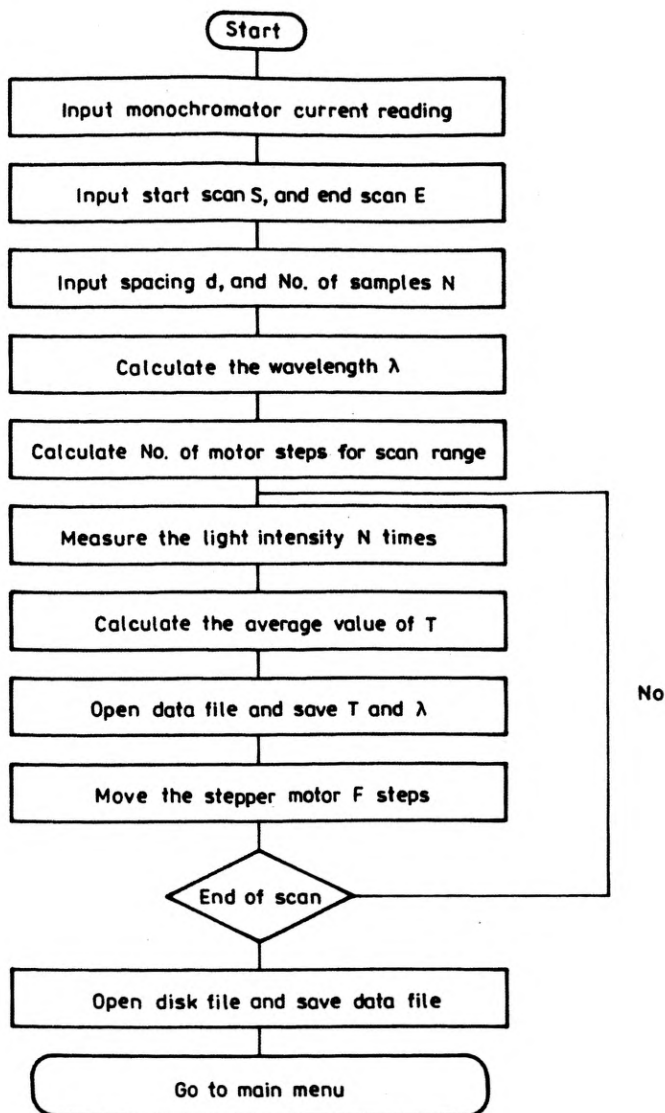

Fig. 2. Flow chart for the program responsible for moving the monochromator and scanning the spectrum

3. Comparative measurements

To test our unit a measurement of the intensity of a Philips tungsten lamp (power 650 W) was carried out using a commercial microdrive unit originally supplied by McPherson and recording the signal on an $x-t$ recorder. The scan was done for a range of wavelength extending from 4000 to 7500 Å. The scan was repeated under the same conditions using, however, the automation unit. The two scans are displayed in Fig. 3. In addition to the drastic cut in time of the full scan, the

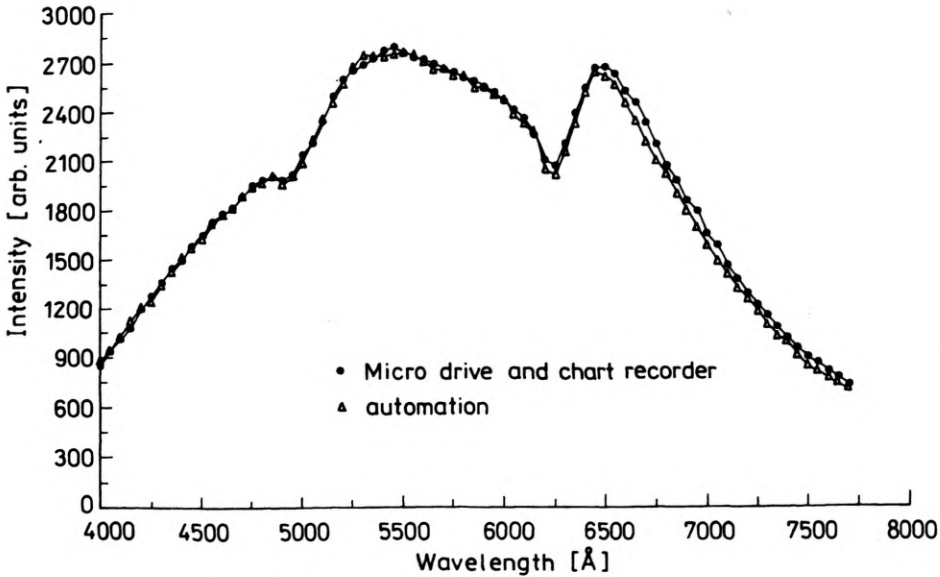

Fig. 3. Typical intensity curve of a tungsten lamp obtained via a microdrive and chart recorder (solid circles), and via the computer interfaced automation unit (empty triangles)

agreement between the two curves was remarkable. Therefore, the unit is practical, efficient and highly favourable.

Acknowledgment — This work was sponsored by the University of Jordan and the University of Science and Technology. Their support is deeply appreciated by the authors.

References

- [1] ABU-ZEID M. E., KOURDIA H. A., YOUSEF Y. A., *Processing and simulation of photoacoustic spectrometer data via a microcomputer*, submitted for publication to the J. Microcomp. Appl.
- [2] *Instruction Manual for Model 2061 Scanning Monochromator*, Serial No. 206106, GCA, McPherson Instrument, Ma (USA), 1968.
- [3] BOYLSTAD R., NASHESKY L., *Electronic Devices and Circuit Theory*, Prentice Hall Inc., 1978.
- [4] GRAHAM L., FIELD T., *Your IBM PC*, McGraw Hill, Berkley, 1984.

Received January 23, 1996