

ELŻBIETA GROCHULSKA-SEGAL\*, APOLINARY L. KOWAL\*, MAREK M. SOZAŃSKI\*

## MODEL OF FILTRATION IN A MULTIMEDIA FILTER BED

The paper presents results of analysis of suspended solids distribution within the depth of double-media filter beds. The laminar flow of water filtrated and the structure of filter beds have been characterized. The changes in the mean gradient of the head loss in filter run at different bed depths have been analysed. The model of high-rate filtration in multimedia beds and the criterion of the model optimization have been presented.

### DENOTATIONS

- $d_z$  — diameter of the bed media grains,
- $g$  — acceleration of gravity,
- $G_M$  — mean gradient of filtration rate,
- $G_w$  — mean gradient of the head loss characterizing the flow of clear water,
- $G_{w1}, G_{w2}$  — maximal values of the mean gradient of the head loss in upper and lower layers, respectively,
- $G_z$  — mean gradient of the head loss characterizing the flow of clear water,
- $G_{z1}, G_{z2}$  — maximal values of the mean gradient of the head loss in upper and lower layers, respectively,
- $\Delta H_z$  — unit depth of bed,
- $H_w$  — depth of water layer above the bed,
- $H_1^*, H_2^*$  — the upper and lower bed layer depths, respectively, at which maximal values of  $G_z$  are stated,
- $K$  — Carman's constant,
- $\Delta P_t$  — increment of the head loss in time  $t$ ,
- $P_0$  — permeability of filtration bed,
- $t_{cf}$  — filter run duration,
- $t_{jf}$  — filter run time after which the filtrate quality deteriorates,
- $t_{wp}^{(1)}, t_{wp}^{(2)}$  — filter run times after which negative pressure occurs in the upper and lower bed layers, respectively,
- $\eta$  — coefficient of dynamic viscosity,
- $V_f$  — filtration rate,

---

\* Institute of Environment Protection Engineering, Technical University of Wrocław, 50-377 Wrocław, pl. Grunwaldzki 9, Poland.

$\varepsilon$  — porosity of filter bed,  
 $\rho$  — water density,  
 $\rho_z$  — filter media density.

## 1. INTRODUCTION

Despite the changes of methods and processes used in the technology of water treatment, rapid sand filters are still a basic equipment in each water treatment and renovation plants. These filters have been many times modified and improved, and their efficiency has substantially increased. The changes have also involved the experimental method used in filtration process; the initially used qualitative description of the phenomena studied was subsequently replaced by the empirical relations and, finally, by mathematical and physical models. Basic assumptions verified experimentally and widely used in modelling of suspended solid filtration refer to the distribution of pollutants within the bed depth [1]. The above assumptions do not allow us to analyse the mechanism of phenomena characterizing the retention of suspended solids in the bed, but only to describe macroscopic course.

The character of pollutant distributions decides upon technological parameters of the process, i. e. on the length of filter run and the time-dependent increment of the head loss, whereas the affinity in the forms of these distributions allows us to infer the affinity of the phenomena occurring in different beds. That is why the modelling of filtration is based on the above-mentioned distributions.

## 2. THE HIGH-RATE FILTRATION MODELS GENERALLY APPLIED

The model of high-rate filtration so far applied refers to sand beds. They give the distributions of mechanical pollutants within the particular bed depths, being an additive resultant of forces and phenomena occurring in bed and responsible for the retention of solid particles.

The surface filtration model assumes the retention of solids in surface layer of the bed solely (fig. 1). Such a kind of filtration takes place in slow sand filter beds. The second model of surface and deep filtration is characterized by the retention of solids on the surface and within the filtration bed (fig. 2). That is why the increment of the head loss is the sum of the increments of the head losses on the bed surface and in the bed pores.

Of the forces acting during water filtration in bed and responsible for suspended solids retention or washing out the following ones should be mentioned, namely: head of passing water, forces of mechanical friction between the suspended particles and filter bed grains, inertia forces, van der Waals's forces, and chemical binding. The suspended particles may be also influenced by the difference in the densities of particles and water.

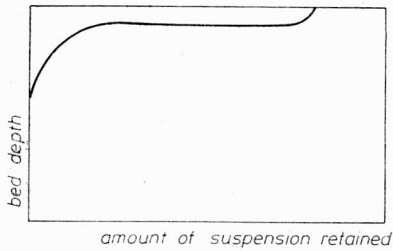

Fig. 1. Surface filtration model

Rys. 1. Model filtracji powierzchniowej

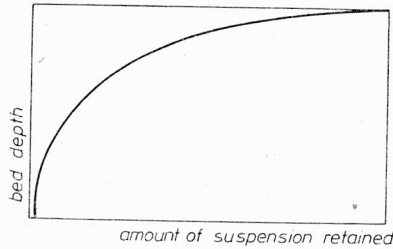

Fig. 2. Surface and deep filtration model

Rys. 2. Model filtracji powierzchniowo-głębokościowej

### 3. AIM, SCOPE, AND METHODS OF INVESTIGATIONS

The purpose of the investigations was to identify the filtration phenomena and to construct a model applicable for multilayer beds. The investigations were conducted in two water-treatment systems presented in fig. 3.

#### EXPERIMENTAL SYSTEM NO.1

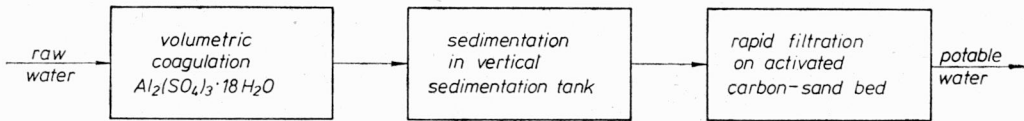

#### EXPERIMENTAL SYSTEM NO.2



Fig. 3. Experimental systems

Rys. 3. Systemy doświadczalne

The scheme of experimental set-up and its description are presented in fig. 4. The coagulant solution was dosed to the rapid mixing chamber the retention time of which was 1 min and rotational speed  $200 \pi \text{rd}/\text{min}$ . The flocculation process took place in a mechanical flocculation chamber of the retention time equal to 20 min and velocity gradient of  $28.0 \text{ s}^{-1}$ . The model of the upflow sedimentation tank consisted of an organic glass pipe of the diameter of  $14 \times 10^{-2} \text{ m}$  and the height of 2.7 m which assured the retention

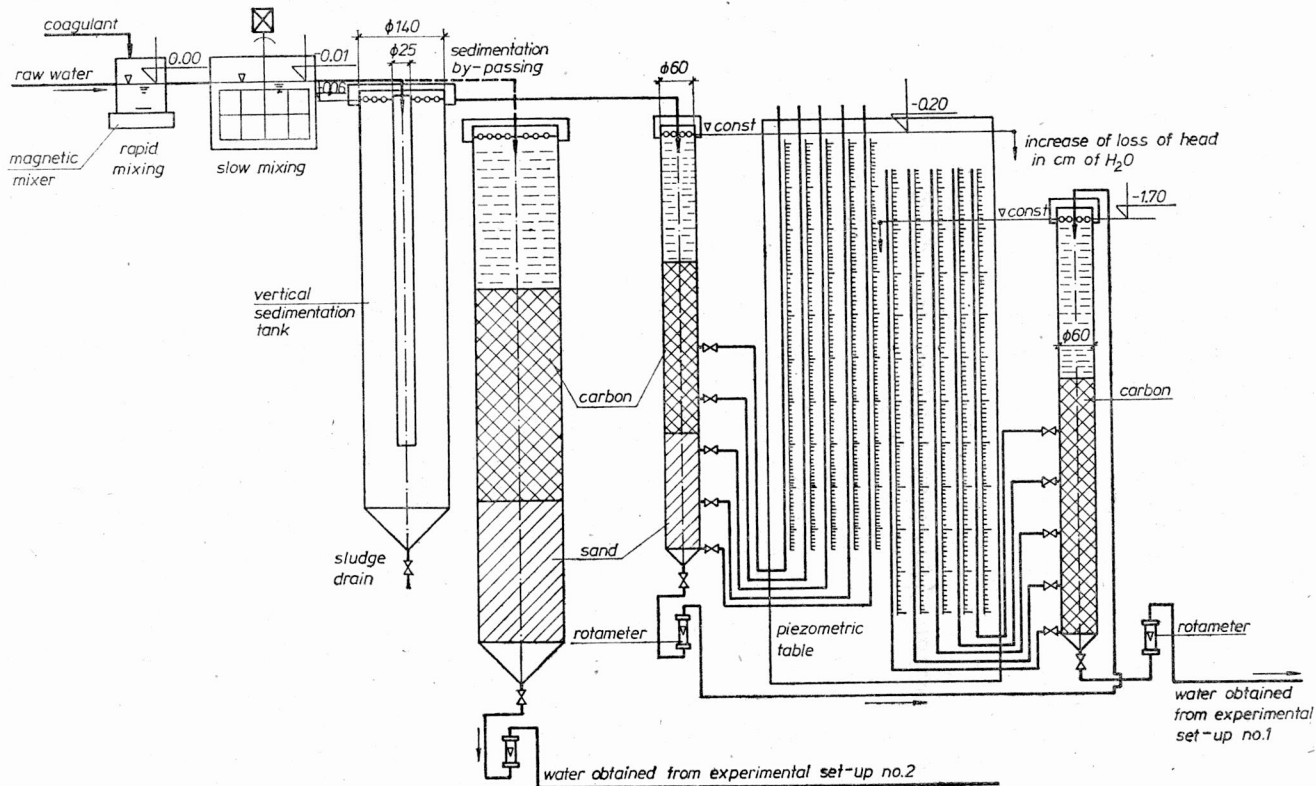

Fig. 4. Experimental installation

Rys. 4. Urządzenie doświadczalne

time of 1.5 h. The diameters of organic glass pipes being the model filters amounted to  $6 \times 10^{-2}$  m and  $14 \times 10^{-2}$  m for the technological systems with and without sedimentation, respectively. The filters had carbon-sand beds of the following grain-size distribution:

activated carbon —  $d_{10} = 0.69$  mm,  $d_{60} = 1.7$  mm,

sand —  $d_{10} = 0.44$  mm,  $d_{60} = 0.65$  mm.

The total depth of the carbon-sand beds amounted to 1.7 m, the ratio of the two layers being 3 : 2. The wall effect of the model filter on the loss of head determined according to BRÖTZ [2] did not exceed 8%. The filtration rate was up to 9.4 m/h. The investigations were conducted in a continuous-flow system. After each run the filters were washed. The turbidity of the river Kaczawa water supplied to the filters varied within 10–30 mg/dm<sup>3</sup>, its colour amounted to 30 mg/dm<sup>3</sup> Pt. The effects of filtration process were estimated by physico-chemical analysis of the filtrate. The turbidity of the filtered water was below 5 mg/dm<sup>3</sup>, and its colour did not exceed 5–10 mg/dm<sup>3</sup> Pt.

The distribution of pollutants within the bed depth was determined indirectly by evaluating the increment of the mean gradient  $G_z$  of head loss during filtration process. The fact that this increment is the function of pollutant retention has been already proved in a number of papers, e. g. MAĆKIEWICZ [6].

#### 4. THE KIND OF WATER FLOW AND IDENTIFICATION OF THE STRUCTURE OF FILTER BEDS

The criterion of laminar water flow in filter is described by linear relationship between the rate of filtration and mean head loss gradient  $G_w$ , the latter being defined by the formula:

$$G_w = \frac{1}{\rho g} \frac{\Delta p}{\Delta H_z}. \quad (1)$$

The investigations have been performed at filtration rates of 5, 7.5, 10, 15, and 20 m/h for 6 different bed depths. The obtained relationships presented graphically in fig. 5 have the linear form. They have been approximated by the equation  $G_w = AV_f$ . The values of the correlation coefficients ranging within 0.996–0.999 prove the deterministic character of the linear dependences obtained.

The identification of the structure of non-polluted beds was based on the values of the head loss stated in the investigations performed at particular depths.

The changes in the head loss stated at particular unit bed depths provide the information about the structure of beds according to the Carman's filtration equation of the form:

$$G_w = \frac{V_f \eta}{\rho g} \frac{K(1-\varepsilon)^2}{\varepsilon^3 d_z^2}. \quad (2)$$

At given temperature the value of the factor  $V_f \eta / \rho g$  is constant and does not change with the bed depth. Thus, the changes in  $G_w$  may be solely caused by the changes of the second factor, i. e.  $K(1 - \varepsilon)^2 / \varepsilon^3 d_z^2$ , which characterizes the bed structure. The changes in  $G_w$  within the depths of the bed tested are presented in fig. 6. The curves obtained for

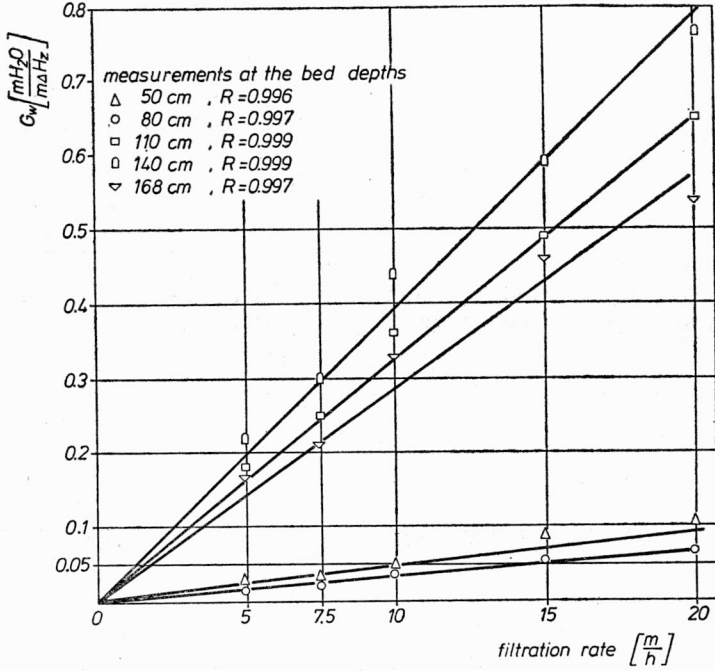

Fig. 5. Filtration rate versus mean gradient of the head loss  $G_w$

Rys. 5. Zależność między prędkością filtracji i średnim gradientem strat hydraulicznych  $G_w$

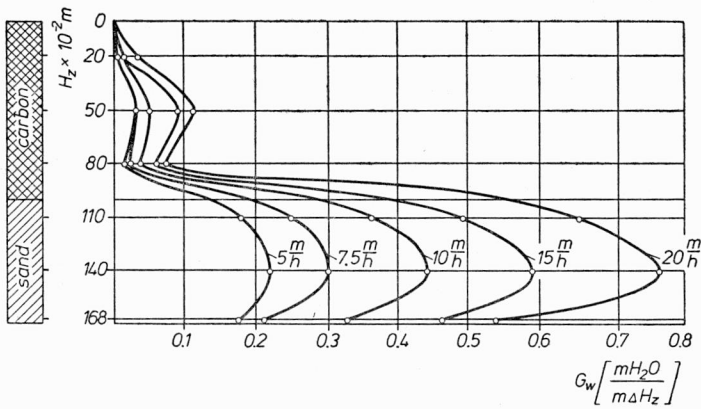

Fig. 6. Gradient of the head loss  $G_w$  versus depth of filter bed

Rys. 6. Charakterystyka zmian średniego gradientu strat hydraulicznych  $G_w$  na głębokości złoża

the layers examined have distinct maxima occurring at the depths of about 0.5 m (carbon) and about 1.4 m (sand) independently of filtration rate. The results presented in fig. 6 have been interpreted using the notion of permeability described by formula:

$$P_0 = \frac{\varepsilon^3 d_z^2}{(1-\varepsilon)^2 K} \quad (3)$$

The notion  $P_0$  is the measure of mean square diameters of pores and capillaries determining the filtration effect. The changes in porosity and permeability occurring within the bed depth (fig. 7) have been determined from the results of investigations (fig. 6) and

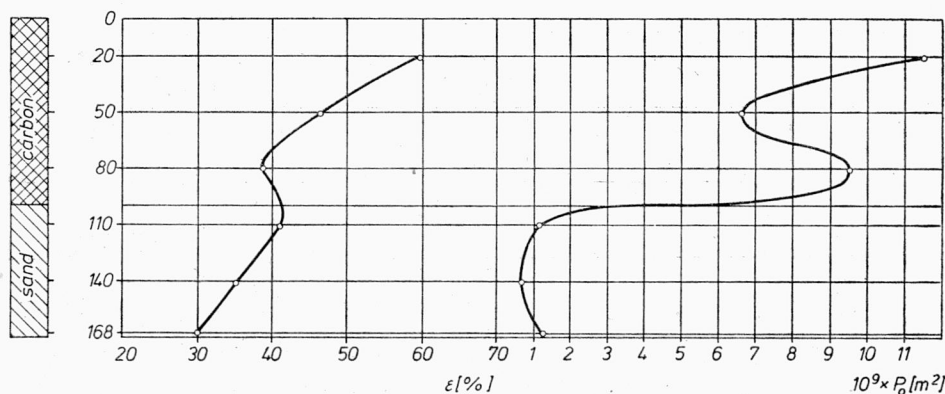

Fig. 7. Characteristics of depth-dependent changes in porosity and permeability of the bed

Rys. 7. Charakterystyka zmian porowatości i przepuszczalności na głębokości złoża

the Carman's formula. The changes in  $P_0$  with depth are correlated with the distribution of the head loss gradients  $G_w$ . Filtration bed zones (where the values of  $P_0$  are minimal) are characterized by the maximal values of  $G_w$  and vice versa. This follows from the comparison of figs. 5 and 6. It should be expected that most of suspended solids will be retained within zones where the values of  $P_0$  are minimal or those of  $G_w$  are maximal.

Correlation between  $\varepsilon$  and  $G_w$  with the depth is less distinct. The characteristic feature is, however, the fact that the porosity of the upper carbon layer is equal to 62% which is caused by low density of the carbon. The identification of the bed structure was also based on the notion of a mean gradient of the filtration rate in bed [3].

The relationship between  $P_0$  and  $G_M$  has been formulated as follows:

$$G_M = \frac{V_f}{P_0} \frac{d_z \varepsilon}{1-\varepsilon} \sqrt{\frac{\rho_z - \rho}{\rho K}} \quad (4)$$

To interpret the filtration effect for different materials it is most essential that the values of  $P_0$  and  $G_M$  be determined, since the first value defines the flocculation conditions in the bed, and the latter the capacity of the particle retention in this bed. For the examined sand-carbon layer the values of permeability and mean gradient of filtration rate

ranging from 5 to 20 m/h are presented in fig. 8. From this figure it follows that there are constant values of permeability in sand bed and filtration rate gradient in activated carbon bed, whereas these values are varying in carbon and sand beds, respectively. The above data indicate that sand beds are characterized by a high and approximately constant

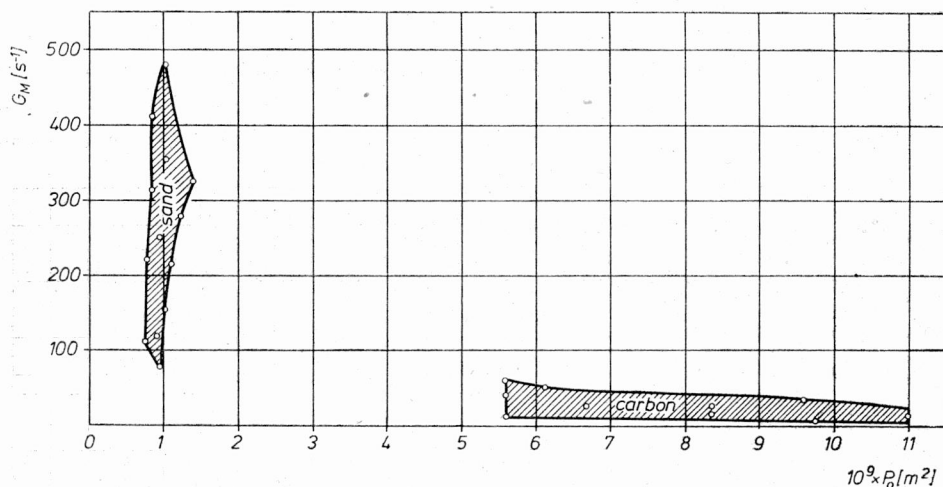

Fig. 8. The regions of  $G_M$  and  $P_0$  values for sand and carbon layers

Rys. 8. Obszary wartości  $G_M$  i  $P_0$  dla warstwy piasku i węgla

retention capacity of suspended solids and approximately constant flocculation conditions in the carbon beds. Another characteristic feature that may be inferred from the above figure is a considerable difference between the ranges of  $P_0$  and  $G_M$  values for sand and carbon, which may significantly affect the optimal control of filtration process in two-layer beds with characteristics differing diametrically or even to make it impossible. Thus, the introduction of a third layer, e. g. an anthracite one, may appear to be indispensable.

## 5. SUSPENDED SOLID DISTRIBUTION IN BEDS AS A BASIS FOR MODELLING OF FILTRATION

The bed depth of pollutants retention has been determined from the changes of the mean gradient of the head loss described by the formula

$$G_z = \frac{1}{\rho g} \sum_{t=0}^{t=t_{ef}} \frac{\Delta P_t}{\Delta H_z} \quad (5)$$



The changes in the value of  $G_z$  occurring within the bed depths describe the retention of suspended solids causing the decrease in the values of  $P_0$  and  $\varepsilon$  of the bed. The results obtained for two filter runs are presented in figs. 9 and 10.

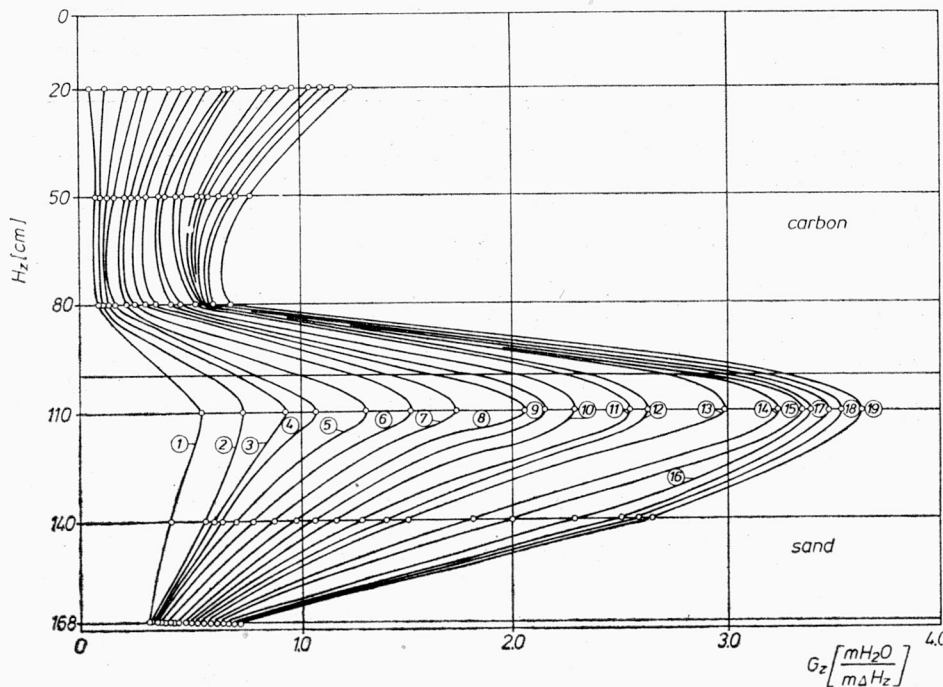

Fig. 9. Mean gradient of the head loss  $G_z$  versus filter bed depth (with sedimentation)

Curves of mean gradients of the head losses after time  $t$

1 - 2h, 2 - 4h, 3 - 6h, 4 - 8h, 5 - 10h, 6 - 12h, 7 - 14h, 8 - 16h, 9 - 18h, 10 - 20h, 11 - 22h, 12 - 24h, 13 - 26h, 14 - 28h, 15 - 30h, 16 - 32h, 17 - 34h, 18 - 36h, 19 - 38h

Rys. 9. Charakterystyka zmian średniego gradientu strat hydraulicznych  $G_z$  na głębokości złoża (z sedymentacją)

Krzywe średnich gradientów strat hydraulicznych po czasie  $t$

1 - 2h, 2 - 4h, 3 - 6h, 4 - 8h, 5 - 10h, 6 - 12h, 7 - 14h, 8 - 16h, 9 - 18h, 10 - 20h, 11 - 22h, 12 - 24h, 13 - 26h, 14 - 28h, 15 - 30h, 16 - 32h, 17 - 34h, 18 - 36h, 19 - 38h

The maximal values of  $G_{z_{max}}$  are observed in both the bed layers. In the carbon layer it appears at the depth not exceeding 20 cm, and in sand bed about 10 cm below the interface. Minimal values in carbon layer occur at the depth of 80 cm, while in sand layer they appear below the gravel layer. The above depths, at which the maximal and minimal values of the gradient have been stated, were constant for all filtration runs. The maximal value of the mean gradient of the head losses of the polluted beds  $G_z$  occurred always above the range of maximal values of the gradient  $G_w$  for the flow of clear water through clean beds, which at the same time had the minimal permeability value. Hence,

it follows that during filtration most of suspended solids are retained at the depth above the minimal permeability zone. The latter acts as a semi-sieve (fig. 11), while the retention of solid particles during filtration may be modelled by the process of a mechani-

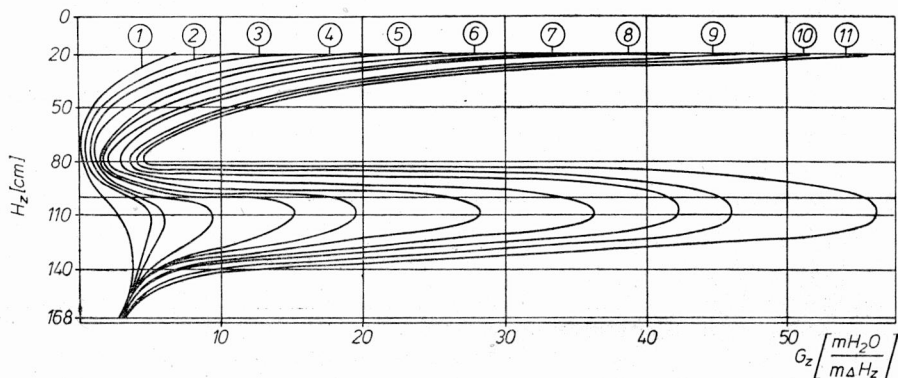

Fig. 10. Mean gradient of the head loss  $G_z$  versus filter bed depth (without sedimentation)

Curves of mean gradients  $G_z$  after time  $t$

1 - 2h, 2 - 4h, 3 - 6h, 4 - 8h, 5 - 10h, 6 - 12h, 7 - 14h, 8 - 16h, 9 - 18h, 10 - 20h, 11 - 22h

Rys. 10. Charakterystyka zmian średniego gradientu strat hydraulicznych  $G_z$  na głębokości złoża (z pominięciem sedimentacji)

Krzywe średnich gradientów  $G_z$  po czasie  $t$

1 - 2h, 2 - 4h, 3 - 6h, 4 - 8h, 5 - 10h, 6 - 12h, 7 - 14h, 8 - 16h, 9 - 18h, 10 - 20h, 11 - 22h

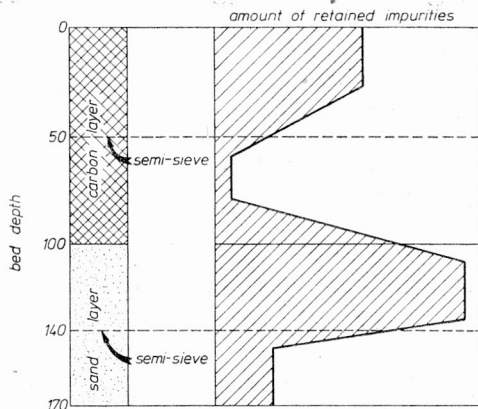

Fig. 11. Filtration model of two-media beds

Rys. 11. Model filtracji na złożach dwuwarstwowych

cal segregation of particles in the bed pores and capillaries taking additionally into account the physico-chemical effects (sorption, adhesion, cohesion, and the structure of flocks). The hypothesis of a semi-sieve was the subject of former papers [4, 5].

## 6. FILTRATION MODEL OF TWO-MEDIA BEDS

The introduction of mathematical relationships allowing the modelling of filtration effects has been based on a semi-sieve existing in each bed layer. The head loss in the filter bed at the positions of maximum values of mean gradient of the head of loss in each layer has to be lower than or equal to the total hydrostatic pressure. This condition is written in the following form:

$$\sum_{\Delta H_z=0}^{\Delta H_z=H_1^*} G_{z_1} \leq H_1^* + H_w, \quad (6)$$

$$\sum_{\Delta H_z=0}^{\Delta H_z=H_2^*} G_{z_2} \leq H_2^* + H_w. \quad (7)$$

The equality in both relations means that the filter run is finished and the filter bed must be washed. The above dependences are the optimization criterion for the treatment of water in open double-media filter beds. If we obtain the equality of only one relation (6) or (7), then the capacity of only one layer was fully utilized. The two layers are optimally utilized and the maximum time of filtration run is achieved if the equality of relations ((6) and (7)) is obtained at the same time. The increase of the value  $H_w$  extends also the filtration run, the latter is, however, limited by the construction of the filter. The gradient of the head loss  $G_z$  depends on size-distribution of the bed, time and rate of filtration, concentration and properties of suspended matter as well as on the dose and kind of coagulants used. The values of  $G_z$  versus the other parameters is determined experimentally.

Assuming the pollutant retention in each bed layer, defined by the same relationships:

$$\sum_{\Delta H_z=0}^{\Delta H_z=H_1^*} (G_{z_1} - G_{w_1}) = f(t), \quad (8)$$

$$\sum_{\Delta H_z=0}^{\Delta H_z=H_2^*} (G_{z_2} - G_{w_2}) = f(t) \quad (9)$$

established experimentally, and assuming the proportionality of the values, defined by the equations (8) and (9) for double-media filters at the end of the filter run, and the values of hydrostatic pressures, the optimization criterion may be presented in the form:

$$\frac{\partial}{\partial t} \left( \sum_{\Delta H_z=0}^{\Delta H_z=H_2^*} (G_{z_2} - G_{w_1}) \right) = \frac{H_2^* + H_w - \sum_{\Delta H_z=0}^{\Delta H_z=H_2^*} G_{w_2}}{H_1^* + H_w - \sum_{\Delta H_z=0}^{\Delta H_z=H_1^*} G_{w_1}} \frac{\partial}{\partial t} \left( \sum_{\Delta H_z=0}^{\Delta H_z=H_1^*} (G_{z_1} - G_{w_1}) \right) = \text{opt. min.} \quad (10)$$

If the experimental relationships (8) and (9) are linear, this criterium is reduced to the form

$$\frac{\Delta \left( \sum_{\Delta H_z=0}^{\Delta H_z=H_2^*} (G_{z_2} - G_{z_1}) \right)}{\Delta t} = \frac{H_2^* + H_w - \sum_{\Delta H_z=0}^{\Delta H_z=H_2^*} G_{w_2}}{H_1^* + H_w - \sum_{\Delta H_z=0}^{\Delta H_z=H_1^*} G_{w_1}} \times \frac{\Delta \left( \sum_{\Delta H_z=0}^{\Delta H_z=H_1^*} (G_{z_1} - G_{w_1}) \right)}{\Delta t} = \text{opt. min.} \quad (11)$$

## 7. CONCLUSIONS

1. The filtration of water in clean filter beds at the rates  $V_f = 5\text{--}20$  m/h should be ranked to the laminar-type flow. The effect of the filtration rate  $V_f$  on the mean gradient of the head loss  $G_w$  was approximated by the equation  $G_w = AV_f$  with the coefficients of correlation from 0.996 to 0.999.

2. The values of the parameters  $G_w$  and  $P_0$  are comprised in distant and non-overlapping sets. Sand beds are characterized by a high and approximately constant retention capacity of suspended solids, whereas carbon beds — by approximately constant conditions of flocculation process.

3. Most of particles — independently of the concentration of suspension — is retained in beds at the depth over the zone of the least permeability. This zone performs the role of a semi-sieve. The hypothesis of a semi-sieve in filtration beds may be used as a basis for modelling and optimization of filtration process.

4. Distribution of suspended solids at the depth of single-media bed follows exponential law, whereas it is not true in double-media beds, where preponderance of suspended solids is retained in the area over the semi-sieve.

5. The criterion presented is in a good agreement with a generalized criterion of Minc:

$$t_{wp}^{(1)} = t_{wp}^{(2)} = t_{jf}$$

6. Both the model and the criterion of optimization, introduced into double-media filter beds, can be adapted for multimedia beds.

## REFERENCES

- [1] KOWAL A. L., SOZAŃSKI M., *Podstawy doświadczalne systemów oczyszczania wód*, Technical University of Wrocław, Wrocław 1977.
- [2] KOWAL L. A., *Technologia wody*, Arkady, Warszawa 1977.

- [3] KOWAL L. A., MAĆKIEWICZ J., *Średni gradient prędkości w filtracji wody*, Inż. Chem., Vol. VII (1977), No. 3.
- [4] KOWAL A. L., SOZAŃSKI M., GROCHULSKA-SEGAL E., *Modelowanie procesu filtracji na złożach dwuwarstwowych* (in press), Scientific Papers of the Technical University of Wrocław.
- [5] KOWAL A. L., SOZAŃSKI M., GROCHULSKA-SEGAL E., *Badania procesu filtracji w modelowym układzie ciągłego oczyszczania wody powierzchniowej* (in press), Conference materials of NOT, May 1978.

### MODEL FILTRACJI W ZŁOŻU WIELOWARSTWOWYM

Opracowanie zawiera wyniki badań rozkładu zanieczyszczeń na głębokości złóż dwuwarstwowych. Zidentyfikowano charakter ruchu filtrowanej wody oraz strukturę złóż filtracyjnych. Przeanalizowano zmiany średniego gradientu wysokości strat hydraulicznych w czasie i na głębokości złóż. Przedstawiono model filtracji pospiesznej na złożach wielowarstwowych. Podano kryterium optymalizacji modelu.

### EIN FILTRATIONSMODELL DER MEHRSCHICHTSCHÜTTUNG

Im vorstehenden Beitrag werden die Reinigungsergebnisse in einem Zweischichtfilter erörtert. Identifiziert wird die Art der Fließbewegung des Filtrats sowie die Struktur der Filterschüttung. Analysiert werden die Abänderungen des durchschnittlichen Gradienten der hydraulischen Verluste vs. Zeit und Schüttungshöhe. Dargestellt wird das Modell der Schnellfiltration durch eine Mehrschichtschüttung wie das Kriterium der Optimierung dieses Modells.

### МОДЕЛЬ ФИЛЬТРАЦИИ В МНОГОСЛОЙНОМ ФИЛЬТРЕ

Разработка содержит результаты исследований распределения загрязнений на глубине двух слойных фильтров.

Были определены характер движения фильтрованной воды, а также структура фильтрующих слоёв. Проанализированы изменения среднего градиента гидравлических потерь во времени, происходящие на глубине слоёв. Представлена модель ускоренной фильтрации на многослойных фильтрах. Предложен критерий оптимизации модели.

