

L. CAMPANELLA*, E. CARDARELLI*, T. FERRI*
B. M. PETRONIO*, A. PUPELLA*

A NEW EXPERIMENTAL APPROACH FOR DETERMINATION TESTS IN CARROT SLUDGE

A modified experimental electrophoretic apparatus to determine metal composition in sludges is proposed. The approach that seems to be very promising is based on the analysis of different zones of the carrot sludge before and after application of electric field. The enrichment or impoverishment of the zones, in comparison with reference composition, gives information about the presence of positive or negative chemical forms of metal species and therefore about their composition.

1. INTRODUCTION

The possibility of entry of toxic compounds from a disposed sludge to the food chain is strictly dependent on the transport mechanisms involved (interactions of sludge-soil, rain water-sludge and ground water-soil). Particularly the fate of metals is related both to the chemical form under which they are initially present in the sludge and to the transformation they undergo along the way they run in the environment [1]-[4]. Thus, the knowledge of the metal composition in a sludge is of primary importance.

A rough metal composition picture is generally obtained by evaluating their solubilities in different media of suitable physico-chemical properties. Thus, it would be of great interest to develop a technique allowing direct evaluation of the different species present in the matrix, without any perturbation of the system [5].

We have previously adopted and described a new approach based on direct electrophoretic measurements for solving the problem [6]. A preliminary analysis of the different zones of the carrot sludge showed that after electrophoresis it is possible to obtain useful information about the species basing on their electrical properties and electrophoretic mobility.

* Department of Chemistry, University of Rome La Sapienza, P. le Aldo Moro 5, Roma, Italy.

Here we propose a useful modification of the mentioned procedure and experimental apparatus. Particularly, the material of the cylinder containing the carrot sludge, the system of mounting and dismounting of the sludge and the analysis procedure involving different zones have been modified.

2. EXPERIMENTAL

The electrophoretic cell (fig. 1) made of perspex allows us to supply ~ 8 g of sludge during an experiment. The cell is filled step by step. Each fraction (~ 2 g) is inserted into the cylinder equipped with two separating disks and then imbibed ($1-2$ cm³) before introduction of a new fraction. The system scheme is shown below; each vertical line indicates a filter paper disk.

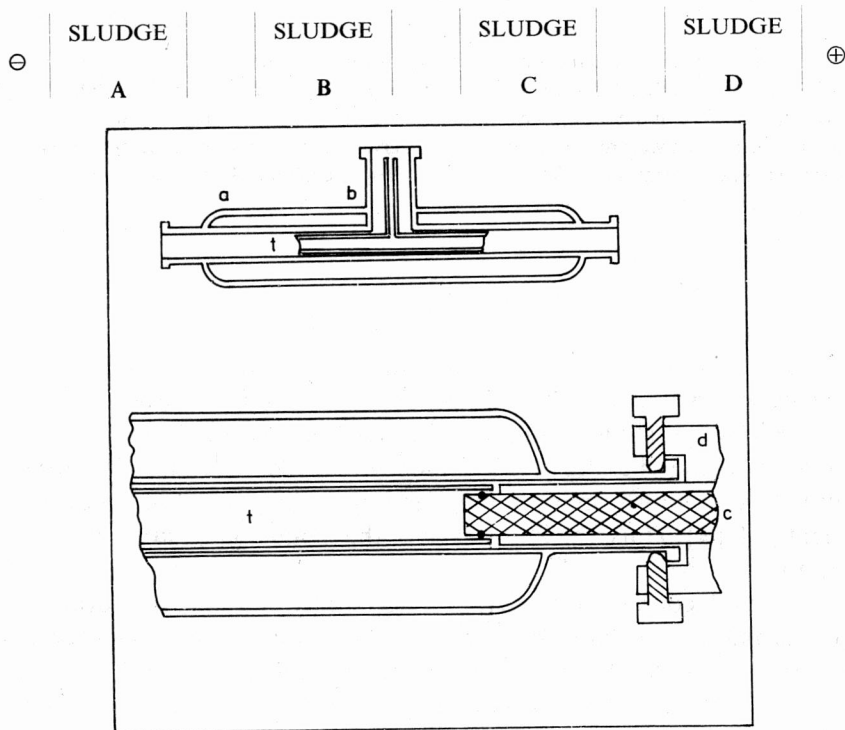

Fig. 1. Electrophoretic cell assembly

a — glass cell with thermostatic jacket, b — drain for gas produced at the electrodes, t — perspex tube containing carrot sludge, c — sintered graphite electrode, d — O-ring and support of electrode made of teflon and PVC, respectively

The new material (perspex in place of glass) used for constructing a cell has been adopted because the previous one gave rise to cementation phenomena. The cell is connected to an e.m.f. supply and a tension of 200 V is applied for 2 h. After

disconnecting of the power supply, the cell is placed in an oven at 105°C. After drying, each fraction, included delimiting zone disks, is collected, and 1 g of dry electrophoresized sludge (homogenized in a mortar) is placed in a centrifuge tube with two paper disks for dissolving treatment.

At first, the sample is treated with 10 cm³ of concentrated HNO₃ until the NO₂ fuming ends, and this treatment is repeated twice. Then 10 cm³ of 35% H₂O₂ are added in small aliquots and the solution is heated for removing nitrogen oxides, then cooled and centrifuged.

The supernatant is siphoned into a 250 cm³ volumetric flask. The residue is washed five times with 30 cm³ of distilled water; the washing fractions after every centrifugation are added to the supernatant solution.

The concentrations of the metals tested in the solution are determined by AAS, while the solid sample undergoes directly thermogravimetric analysis.

All the results are referred to a blank determination constituted by the same sample (the same components added) to which no electric field is applied.

3. RESULTS AND DISCUSSION

Figures 2–4 show the distribution of each metal in the carrot sludge (four zones) after electrophoresis carried out in two media (water and pyrophosphate). The values reported are referred to blank tests (see above).

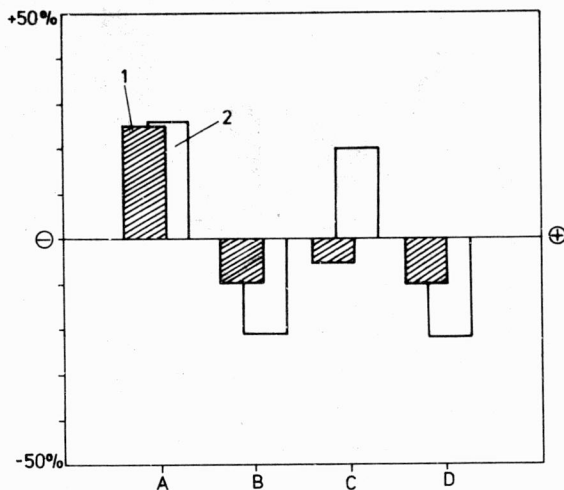

Fig. 2. Zinc content in different zones

The percentages are referred to the blank value. 1 — Na₄P₂O₇, 2 — water

As it can be seen, the behaviour patterns of the three metal ions investigated are markedly different: the cathodic zone is enriched with zinc, while the other ones are

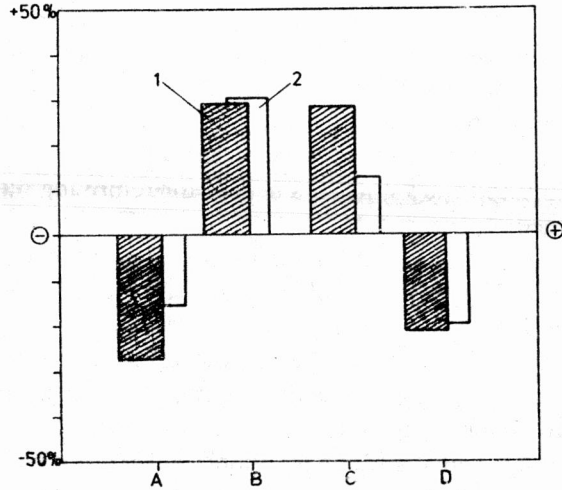

Fig. 3. Copper content in different zones

The percentages are referred to the blank value. 1 — $\text{Na}_4\text{P}_2\text{O}_7$, 2 — water

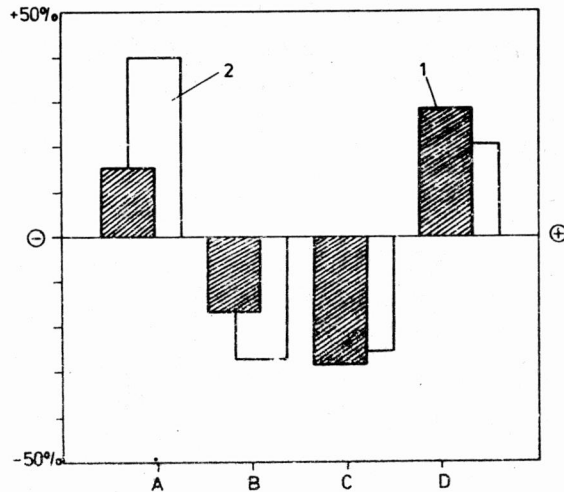

Fig. 4. Lead content in different zones

The percentages are referred to the blank value. 1 — $\text{Na}_4\text{P}_2\text{O}_7$, 2 — water

impoverished by it. The highest concentration of copper is achieved in the middle zones at the cost of the zones contacting electrodes, finally, lead presents an antagonistic behaviour to copper. In this case, contrarily to the batch experiments, the nature of media seems to have poor effect. It should be mentioned, however, that in the present experiments only a few milliliters of solutions (necessary for sludge imbibition) are used against a few hundred milliliters in batch experiments (under

stirred conditions for a long time). At the present time, no clear explanation of the electrophoretic results can be given, but only tentative hypothesis may be formulated. For instance, the behaviour of metal ions in the cathodic zone could be explained on the basis of red-ox properties of the three metals. In fact, while copper reduction may occur, reduction of both lead and zinc should be prevented by hydrogen discharge. In consequence of electrophoresis, the cathodic zone (A) would be poorer in copper and richer in lead and zinc.

As regards the whole trend (all zones), the results obtained seem to be in a general agreement with previous ones. Particularly, an electrophoretic behaviour of zinc is in agreement with large availability of its free form present in the sludge in higher percentage than the other ones. Thus, while zinc electrophoretic behaviour seems to be clear enough, that statement is not true for copper and lead. However, their behaviour patterns should be related to the chemical forms in which they are present in the sludge.

In our opinion, in order to improve the comprehension of the electrophoretic trends, in future experimental work organic matter characteristics should be also taken into account as it plays an important role both in liquid and solid phases.

REFERENCES

- [1] CAMPANELLA L., CARDARELLI E., FERRI T., PETRONIO B. M., PUPPELLA A., *Sci. Total Environ.*, 61 (1987), 217-228.
- [2] PETRONIO B. M., CAMPANELLA L., CARDARELLI E., FERRI T., PUPPELLA A., *Ann. Chim.*, 77 (1987), 721-733.
- [3] CAMPANELLA L., FERRI T., PETRONIO B. M., PUPPELLA A., *Ann. Chim.*, 1989 (in press).
- [4] CAMPANELLA L., CARDARELLI E., FERRI T., PETRONIO B. M., PUPPELLA A., *Sci. Total Environ.*, 76 (1988), 41-48.
- [5] LALVANI S., PATA M., COUGHLIN R., *Fuel*, 65 (1986), 122-128.
- [6] PUPPELLA A., CAMPANELLA L., CARDARELLI E., FERRI T., PETRONIO B. M., *Sci. Total Environ.*, 64 (1987), 295-301.

NOWA METODA ANALIZY JAKOŚCIOWEJ W OSADACH Z PRZEROBU MARCHWI

Przedstawiono zmodyfikowane urządzenie elektroforetyczne do oznaczania składu metali w osadach. Proponowana metoda wydaje się bardzo obiecująca. Jest ona oparta na analizie różnych warstw osadu (pochodzącego z przerobu marchwi) przed i po wprowadzeniu pola elektrycznego. Wzbogacenie lub zubożenie składu poszczególnych warstw osadu w stosunku do składu układu odniesienia umożliwia otrzymanie informacji o obecności ujemnie lub dodatnio naładowanych jonów, co pozwala na określenie składu metali w osadzie.

НОВЫЙ МЕТОД КАЧЕСТВЕННОГО АНАЛИЗА В ОТЛОЖЕНИЯХ, БОЗНИКАЮЩИХ ПОСЛЕ ПЕРЕРАБОТКИ МАРКОВИ

Представлена новая электрофоретическая установка для определения состава металлов в отложениях. Предлагаемый метод кажется обещающим. Он базируется на анализе слоев

отложения (возникающего во время переработки марки) перед и после введения электрического поля. Обогащение или обеднение отдельных слоев отложения по отношению к составу системы отпесения дает возможность получить сведения на тему наличия отрицательно или положительно заряженных ионов, что позволяет определить состав металлов в отложении.