

## A contribution to the study of radiation-induced changes in some sorts of glass\*

STANISŁAW GĘBALA, IRENEUSZ WILK

Institute of Physics, Technical University of Wrocław, Wybrzeże Wyspiańskiego 27, 50-370 Wrocław, Poland.

### 1. Introduction

In this work some examples of radiation-induced modifications in internal structure of BK 101 and BK 107 glasses are examined and recorded in the setup presented in fig. 1. They result in respective phase and amplitude changes of the visible light beams used to examine these structural changes, which make them detectible. Also the respective treatment to erase the induced patterns have been examined. As a testing object some gratings of both constant and variable periodicity were used.

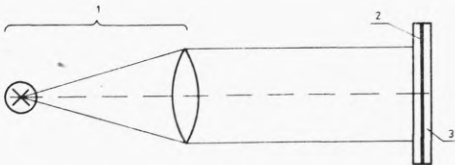

Fig. 1. The optical setup for glass plates irradiation: 1 - HBO-200 lamp, 2 - masking grating on a photographic plate, 3 - plate of glass to be tested

As it is well known multivalent ions present in the borium silicon glasses, such as BK 101 and BK 107, are subject to oxidizing-reducing changes when affected by near ultraviolet radiation. Cerium, arsenium, ferrum and other ions used as the material imperfections participate in these changes. At the elevated temperatures in the absorption band of  $Ce^{3+}$  the changes occurring in the glasses interacting with the radiation were due not only to cerium but also to all the other doping ions. After returning to the room temperature no

erasing processes are observed. The reverse changes may be evoked first at much higher temperatures. The changes in absorption are connected with the changes of oxidation degree the greatest of which occur in the charge transition bands between 200 nm and 300 nm. The absorption changes are accompanied by the changes in refractive index. An accurate description of this affect may be found in the works [1-5]. On the base of these properties different masks, modifying the inducing radiation structure, were used to stimulate the respective spatial changes in the glass structure. We have decided to use gratings (exploited also in [2]).

In order to maximally simplify the recording of grating structures a photo-detective system of quick recording on a sheet recorder was applied. This allows to observe many effects, for instance, the influence of the setup geometry on the induced variation in glass structure. On the other hand, this setup enables to record the desired effects not only before and after the thermal treatment but also during this process.

### 2. Experimental results

As the material under test the BK 101 and BK 107 glasses were used, which belong to the catalog of optical glasses produced by Optical Works in Jelenia Góra (Poland). The glass samples being cut out of the glass blocks in the form of glass plates of thickness  $d = 1.5$  mm polished, were on both sides.

\* This work was carried out under the Research Project M.R. I.5.

The mercury HBO-200 lamp of Zeiss make was used as the irradiating beam source. An attempt has been made to achieve the best possible collimated inducing radiation beam. Beside the single sample plates also the plates piles were irradiated by using the divergent beams.

The photographic gratings of changing frequency  $f = 2 \frac{\text{line pairs}}{\text{mm}} - 20 \frac{\text{line pairs}}{\text{mm}}$  and of constant frequency  $f = 5 \frac{\text{line pairs}}{\text{mm}}$  recorded on photographic plates were used as the masks of inducing radiation.

In order to visualize the changes induced in glass plates by the masked irradiation a setup shown in fig. 2 was applied. It was composed of halogen 100 W lamp

### 3. Results of examinations

The presentation of the results of examined examples will be started with showing the differences in the induced gratings in the BK 101 and BK 107 glass plates (see curves 1 and 2 in fig. 3). The gratings were induced by irradiation under identical conditions. During reconstruction (visualization) IF 400 filter was used, while the slit was of 0.05 mm width. When visualizing the induced changes with the help of the setup shown in fig. 2 in the BK 101 glass amplitudes observed are greater than those induced in BK 107 samples.

A fragment of the grating induced in the BK 107 glass plates and visualized in the observation plane is shown in fig. 4. This plate was next subject to successive

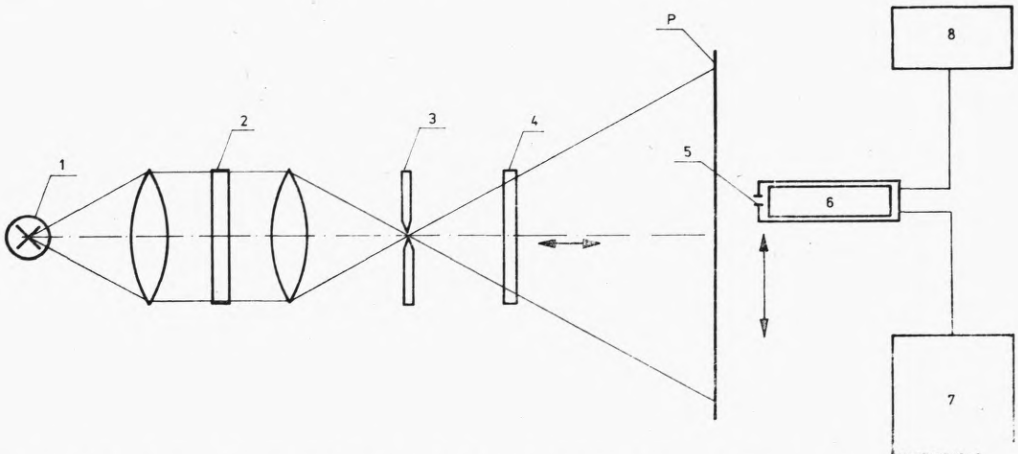

Fig. 2. Block scheme of the system visualizing the internal structural changes in irradiated glass plates: 1 - halogen lamp (100 W), 2 - interference filter, 3 - regulated slit, 4 - plate irradiated in setup from fig. 1, 5 - pinhole in observation plane, 6 - M10FQS29 photomultiplier, 7 - K-100 recorder, 8 - ZWN 25 supplier

of Zeiss production as a light source, interference filters, regulated slit and M10FQS29 photomultiplier with a pinhole at its input. The photomultiplier was shifted on the stage by a synchronic engine. The light intensity distribution at the observation plane was recorded on K-100 recorder of Zeiss make. The glass plates with irradiated grating were heated in a furnace at fixed temperature to examine their erasability. The same plates were subject to multiple irradiations and erasing.

thermal treatment at 823 K temperature for 0.5, 1 and 2 h, respectively, so that the total period of thermal treatment at this temperature was 3.5 h. As may be seen, the due erasing effect is very pronounced as the amplitude quickly falls down to zero. The BK 101 glass requires much less time to erase the induced structure which is illustrated in fig. 5. The reconstruction (visualization) in the observation plane was carried out with monochromatic light of  $\lambda = 400 \text{ nm}$  for the slit width equal to

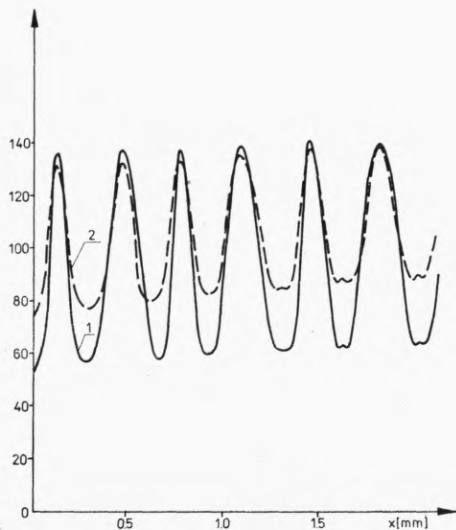

Fig. 3. Light intensity distribution ( $i$ ) in the observation plane setup shown in fig. 2 generated by the induced grating structures in BK 100 (1) and BK 107 (2) glass plates, respectively ( $\lambda = 400$  nm,  $d = 0.05$  mm);  $i$  - in conventional units

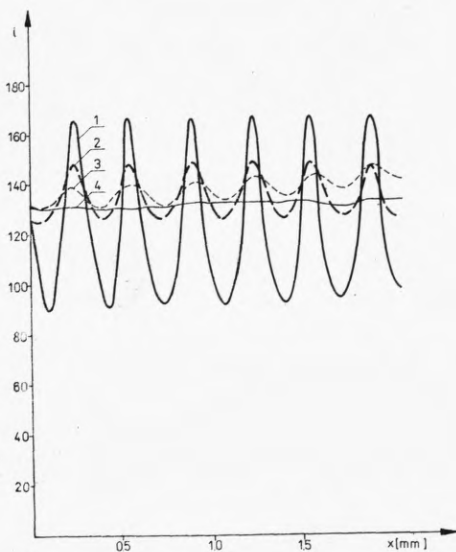

Fig. 4. Light intensity distribution ( $i$ ) in the observation plane of setup from fig. 2, induced grating structures in the BK 107 glass plates: 1 - initial state, 2 - after 0.5 h annealing at 823 K, 3 - after 1.5 h annealing at 823 K, 4 - after 3.5 h annealing at 823 K ( $\lambda = 400$  nm,  $d = 0.03$  mm);  $i$  - in conventional units

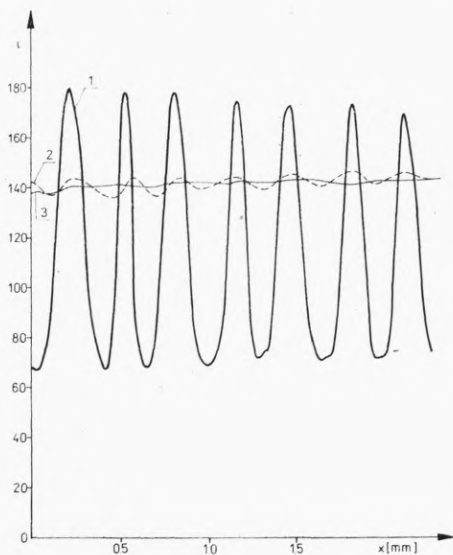

Fig. 5. Light intensity distribution ( $i$ ) in the observation plane of setup from fig. 2, induced grating structures in the BK 101 glass plates: 1 - initial state, 2 - after 0.5 h annealing at 823 K, 3 - after 1.5 h annealing at 823 K ( $\lambda = 400$  nm,  $d = 0.03$  mm);  $i$  - in conventional units

0.03 mm. In figure 6 the record of the light intensity distribution in the observed plane generated by the BK 101 glass plate after first irradiation (curve 1) is given. The induced structure was then twice erased and again irradiated (curve 2). The periodic light intensity distribution was produced this time also by using the light of  $\lambda = 400$  nm and for the slit width equal to 0.03 mm.

In figure 7 some fragments of the record of light intensity distribution generated in the observation plane of the setup from fig. 2 by each of four plates of thickness 1.5 mm and arranged in a pile during the irradiation are given. This time the light beam used for visualization is divergent. No immersion liquid was applied. As it may be seen in the first plate a "normal" grating has been induced, in the second plate the structure is much weaker, while in the third one the grating effect is a little more significant but shifted in phase with respect to the first two. In the fourth plate the grating effect is again weaker and slightly deformed. This may be explained by the geometry of the ir-

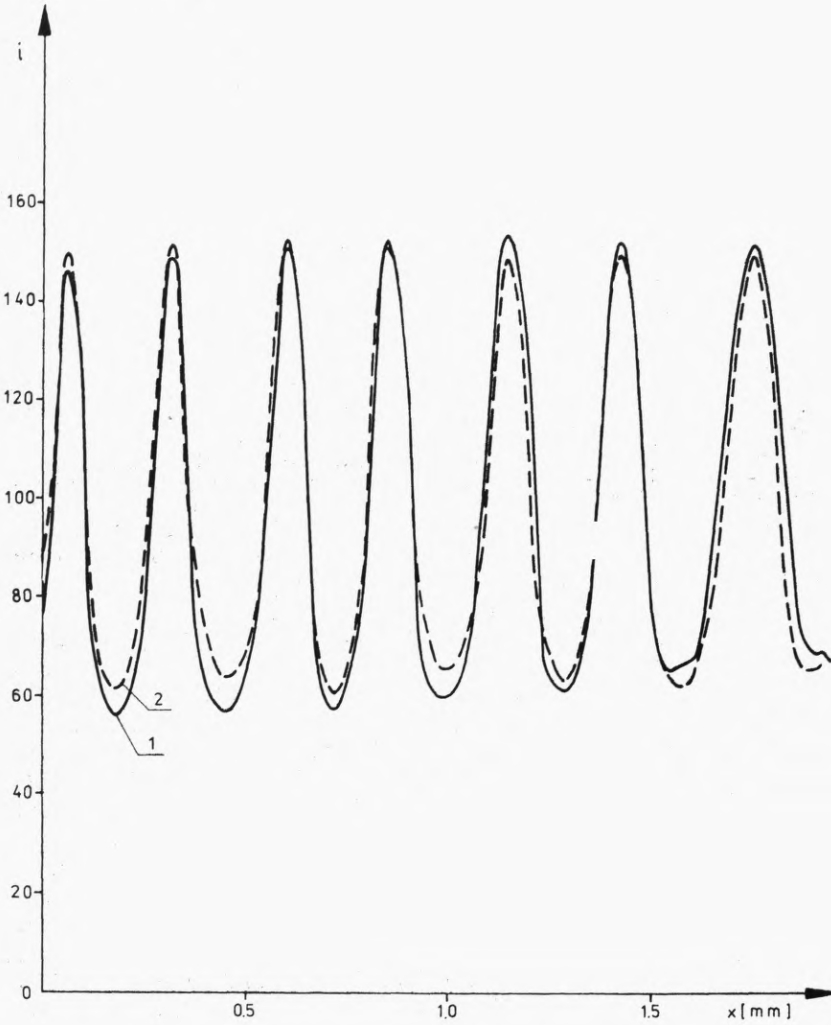

Fig. 6. Light intensity distribution ( $i$ ) in the observation plane of setup from fig. 2, induced grating structures in the BK 101 glass plate: 1 - initial state, 2 - after threefold erasing and inducing ( $\lambda = 400 \text{ nm}$ ,  $d = 0.03 \text{ mm}$ );  $i$  - in conventional units

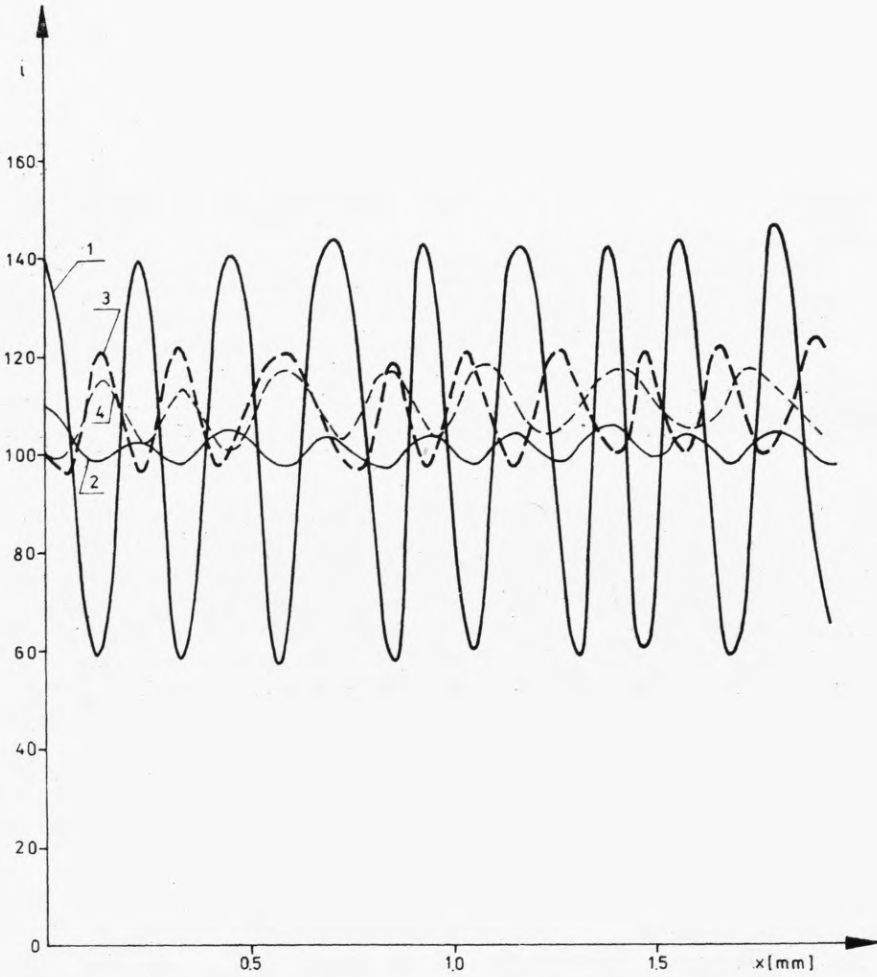

Fig. 7. Light intensity distribution ( $i$ ) in the observation plane of the setup from fig. 2 generated, respectively, by successive single BK 101 glass plates of thickness 1.5 mm from the plate pile described in the text ( $\lambda = 400$  nm,  $d = 0.06$  mm);  $i$  - in conventional units

radiating beam within the pile region. The grating effect was visualized via IF 400 filter and for slit width equal to 0.06 mm.

In figure 8 the upper curve represents the dependence of the ratio of light distribution amplitude  $a$  to the background level

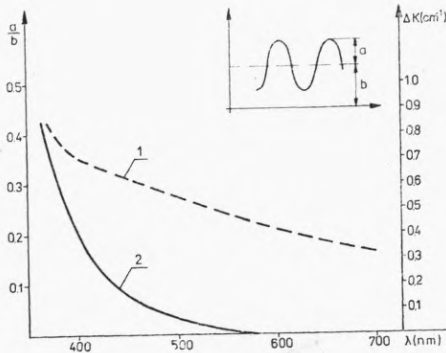

Fig. 8. Dependence of the amplitude-to-background ratio and the absorption coefficient upon the wavelength of the reconstructing beam for the BK 101 glass plates

$b$  on the wavelengths. In the same figure the total absorption coefficient induced in the glass due to the near ultraviolet irradiation is shown. The absorption was measured in the Specord UV VIS spectrometer for the samples positioned so that the induced grating lines be perpendicular to the spectrometer slit. The measurement results

were than normalized to the unit thickness of the sample ( $\text{cm}^{-1}$ ).

#### 4. Conclusions

Application of gratings as masks modifying the internal structure of glass when irradiated by the respective radiation allows to examine the influence of different conditions, starting from the setup geometry used for structural change stimulation to the influence of the thermal treatment. This allows to accelerate the examinations of the application of the oxidizing-reducing process in multivalent ions in glasses to information recording as well as to other purposes in applied optics.

At the room temperature the induced structural changes proved to be stable. The changes were completely erasable first at the temperature 823 K, i.e. at the transformation temperature. The glass plates may be used for multiple information recording.

The dependence of the grating amplitude to the background level ratio upon the wavelength of the visualizing beam seems to be very interesting though not quite clear since it bears some information about the local changes in optical glass structure. This problem requires some further examination.

#### References

- [1] GĘBALA S., *Szkło i Ceramika* **23**(1977), 201.
- [2] GĘBALA S., *ibidem*, p. 318.
- [3] GĘBALA S., RYSIAKIEWICZ E., *Optica Applicata* **VIII** (1978), 149.
- [4] GĘBALA S., PAWLIK E., *Optica Applicata* **VIII** (1978), 89.
- [5] GĘBALA S., RYSIAKIEWICZ E., *Szkło i Ceramika* **30** (1979), 65.

Received March 17, 1981

Dear Editor,

After having read the paper *Generalized Treatment of Fourier Transforming by Lenses*, *Optica Applicata*, Vol. X. No. 3, 1980, p. 237, by Eugeniusz Jagoszewski, I would like to make some comments. The aim of the author was – as it follows from the paper – to generalize the Fourier transform operation derived for thin lens to that for thick lens. The need of such generalization is unclear to me since when starting from the properties of the composed optical system it is possible to obtain immediately the conclusions for a single lens. The consideration of thin lens concept seems to have only a purely didactic meaning.

Besides, the discussion presented in the paper contains some essential mistakes. The treatment of the thick lens as a system composed of two thin lenses, one of which being responsible for the effects caused by the thickness of the original thick lens, may, perhaps, be an interesting formal manipulation, but is not based on a physical model. The further discussion in this paper referring to the analogy of summing the optical systems is incorrect, since the proposed formal model is incoherent with the physical one. Consequently, the fig. 3 is erroneous.

The estimation of the spatial frequency error (formula (20)) is unclear to me, since here we have to do with the object spectrum which is independent of the focal length of the system and only the localization of the particular harmonics of the spectrum is changed.

I would appreciate your publishing the above remarks.

Sincerely yours  
Romuald Józwicki

Warszawa, December 8, 1980

*Received December 12, 1980*

Dear Editor,

In reply to the letter of Doc. Dr. Romuald Józwicki of December 8, 1980 I feel obliged to make the following comments. My paper

*Generalized Treatment of Fourier Transforming by Lenses* was devoted to the problem of Fourier spectrum formation of complex amplitude in real optical elements. The implementation of Fourier transform with the help of real (thick) convergent lens was there discussed as compared to the commonly used formulations referred to the ideal (infinitesimally thin) lens of the same constructional parameters. The purpose of this paper was to show the difference in operation of those two types of lenses (of the same curvatures and made of the same glass, but differing in their thicknesses) as far as the Fourier transform of the same fixed object distribution is concerned. The other aim was to determine explicitly the influence of the lens thickness on the change in complex amplitude distribution in the image focal plane.

Due to the change of focussing properties of the lens when varying its thickness, the spatial frequency of spectrum distribution of a given object is focussed in two different image focal planes, i.e. in that of the infinitesimally thin lens and of the thick lens one. This situation is shown just in fig. 3, while its justification is provided by formulae (10)–(13). Therefore, I cannot grasp the sense of Dr. R. Józwicki's statement that ... "The further discussion in this paper ... is incorrect ... Consequently, the fig. 3 is erroneous". It is unclear what is incorrect here? On the other hand, these considerations are based on the formula (10) which has not been questioned yet. Hence, if this "interesting formal manipulation" has no physical model it should contain some errors or erroneous is the assumption (formula (10)) forming the basis of discussion.

For the obvious reasons the operation of a thin lens may not be identified with that of a real lens. Thus, I must say again that due to different focussing properties of the two examined lenses the spectrum distributions of the same object are different. It does not mean, however, that the spatial frequencies of a given object change depending on the focussing proper-

ties of the lens used. We simply measure the frequencies in two different planes (see fig. 3), in which the spectrum is focussed. If, for instance, a photoplate of sizes  $(2\xi_0 \times 2\eta_0)$ , is applied, then the range of recorded frequencies depends on the position of the recording plane and thus on the focal length of the lens. The maximal values of the spatial frequency of the spectrum created with the help of an infinitesimally thin lens are defined by the formulae

$$\omega_{0x} = \frac{2\pi}{f_0} \xi_0, \quad \omega_{0y} = \frac{2\pi}{\lambda f_0} \eta_0,$$

while the maximal values of the spatial frequencies components of the spectrum

formed with the help of the thick lens are defined by the formula (19). If we calculate the spatial frequencies of the spectrum on the base of the commonly used Fourier transform by a thin lens, the latter will differ from spatial frequency spectrum of the same object produced by the respective thick lens. This error is determined by formula (20) and illustrated with the graph in fig. 4 for three different pairs of lenses.

Sincerely yours

*Eugeniusz Jagoszewski*

Wrocław, December 16, 1980

*Received December 18, 1980*