

A multifunctional optical system for laser technique

A. DROBNIK, K. ROŻNIAKOWSKI

Institute of Physics, Technical University of Łódź, Łódź, Poland.

R. KAZANA

Polish Optical Plant, Warsaw, Poland.

In this paper both the design and principles of operation of a UTM device constructed at our Institute are presented. The device may be used to transport laser radiation energy to a definite place of the irradiated substance, to adjust the radiation parameters like the power density, to form the beam cross-section, as well as to control and estimate the results of irradiation.

Such optical systems may be used as an accessory of technological laser arrangements and, to the knowledge of the authors, have not been produced in Poland yet. The UTM device has been built mainly of the mass production elements produced in Poland.

The UTM device designed and constructed by us is an original technical solution. The photo of the device and the respective optical systems are shown in Figs. 1 and 2.

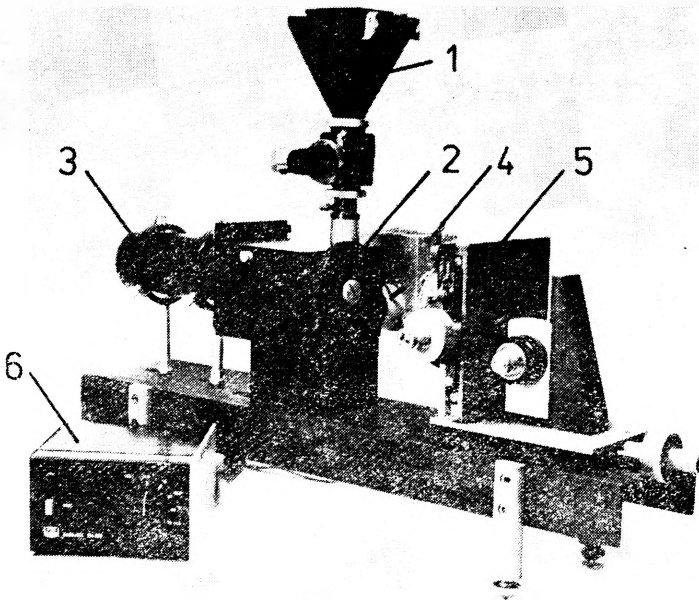

Fig. 1. Photography of telescope-microscope system: 1 – MNF attachment device with micrometric ocular, 2 – reflecting microscope, 3 – telescope, 4 – illuminator, 5 – multifunctional optical table, 6 – feeder of illuminator

When the laser light source is located close to the entrance pupil of the optical system then the least diameter of the concentrated radiation is positioned at the focal plane of the system used [1-4]. The diameter of the light spot at the focal plane may be then calculated from the formula

$$d = f\theta, \tag{1}$$

where f – focal length of convergent lens,
 θ – divergent of beam.

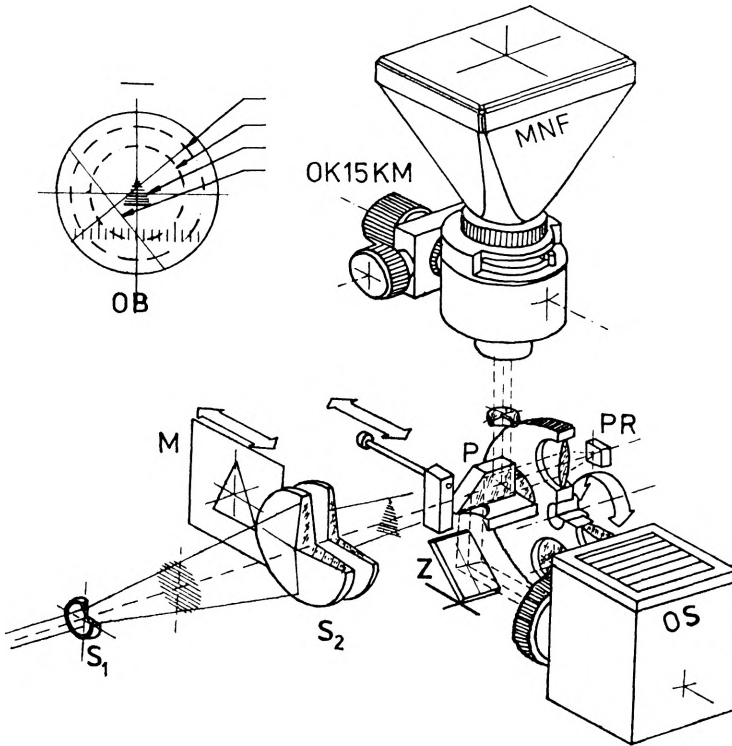

Fig. 2. An optical scheme of the telescopic-microscope system: S_1, S_2 – lenses of the telescopic system, M – mask, OS – illuminator, P – prism set (enabling to the observation of the sample and removed from the beam trajectory during the irradiation), Z – mirror, PR – irradiated sample, OB – image observed in the OK15KM ocular, MNF – photographic attachment

It results from the formula (1) that in order to reduce the diameter of the light spot with a given divergence of the light beam it is absolutely necessary to shorten the focal length of the system which, in turn, leads to the shortening of its working distance. This shortening is disadvantageous, as the chips (of e.g. metal) being formed during irradiation may damage or destroy the last lens of the system. Therefore, the possibility of focussing the radiation on a light spot, having the diameter of several micrometers with a big enough working distance, is ensured by placing a telescope system in front of a long-focal object glass. The diameter of a light spot will in this case be determined by formula

$$d = \frac{f\theta}{F}, \tag{2}$$

where F – magnification of the telescope.

In UTM 6-fold magnifying telescope (3 in Fig. 1) consisting of iris diaphragm P , divergent lens S_1 , convergent lens S_2 , mask M has been applied. The above mentioned elements have been fixed in a metal (blackened) housing enabling to change the distance between S_1 and S_2 lenses.

As an optical system used for the observation of the irradiated area, a microscope magnifying 5–200 times is usually applied. The simplest solution of this type is the application of a typical microscope which can be placed at an angle with respect to the optical focussing axis of the object-glass. In this case the focussing object-glass and the control microscope make two independent systems. However, by placing the microscope at a certain angle it becomes difficult to irradiate the inaccessible spots of the sample examined, since then a part of a field of vision is not sharp, and this, in turn, makes it difficult to carry out the control and measurements in the irradiation areas. These faults do not occur in the optical devices whose focussing and controlling system have a common object-glass.

Such a solution has been applied in UTM, where the focussing and observation systems (reflecting microscope 2, Fig. 1) have common replaceable object-glasses with focal distance of 57, 96 and 137 mm.

In such optical systems the beam of laser light can achieve accurately the determined spots on the sample due to the use of micrometric oculars and optical tables, which ensure a high accuracy of steering the radiation and the sample. In UTM this function is performed by the application of micrometric ocular OK 15 KM and multifunctional optical table 5 (Fig. 1) the latter being composed of subsystems of Fedorov's table and toolmaker's microscope table.

The system constructed performs the functions listed in the Introduction due to possibility of:

- changing the geometry of the sample being irradiated, at a constant radiation energy level,
- changing the radiation energy at a constant irradiation geometry,
- shaping the light-beam cross-section (diaphragm, mask),
- observing and recording the irradiation results by means of a microscope.

It should be mentioned that the system presented has been built of the elements produced by Polish Optical Plant, Warsaw.

The described UTM system proved useful in many investigations carried out in the Institute of Physics, Technical University of Łódź, in which the quantity and functionality of the system were checked. The usefulness of the device was especially remarkable in the following activities:

- the boring of small calibrated orifices in metals by means of laser light beam [5],
- the capillary wave formation in metals by means of laser light beam [6–9].

Acknowledgements – The authors are indebted to Mr. W. Fiedeń, M.Sc., for the discussion and assistance in performing nontypical elements of UTM.

References

- [1] RYKALIN N. N., UGLOV A. A., KOKORA A. N., *Lazernaya obrabotka materialov*, Izd. Mashinostroenie, Moskva 1975.
- [2] STELMACH M. F., (Ed.), *Lazery v tekhnologii*, Izd. Energiya, Moskva 1975.
- [3] MIRKIN L. J., *Fizicheskie osnovy obrabotki materialov luchami lazera*, Izd. Moskovskogo Universiteta, Moskva 1975.
- [4] KOVALENKO V. S., *Obrabotka materialov impulsnym izluceniem lazerov*, Kiev 1977.
- [5] DROBNIK A., (ed.), *Badania nad możliwością drążenia małych kalibrowanych otworów w metalach wiązką światła lasera*. Politechnika Łódzka, Instytut Fizyki, Cz. I, 1975/76, Cz. II 1976, Cz. III 1978 (in Polish).
- [6] DROBNIK A., JABŁOŃSKI W., ROŻNIAKOWSKI K., *Mat. Res. Bull.* **13** (1978), 731–735.
- [7] DROBNIK A., ROŻNIAKOWSKI K., JABŁOŃSKI W., *Mat. Res. Bull.* **14** (1979), 1049–1052.
- [8] DROBNIK A., ROŻNIAKOWSKI K., ROŻNIAKOWSKA E., *Mat. Res. Bull.* **15** (1980), 1457–1460.
- [9] ROŻNIAKOWSKI K., Doctor's Thesis, Technical University of Łódź, Łódź 1979.

Received May 10, 1981