

JACEK JEŻOWSKI*, GRZEGORZ POPLEWSKI*, ALINA JEŻOWSKA*

OPTIMIZATION OF WATER USAGE IN CHEMICAL INDUSTRY

The paper deals with the problem of designing optimal water networks in chemical and related branches of industry. Water networks consist of water-using system and wastewater-treatment system. The objective is to design the network that uses the minimal amount of freshwater. The problem is of a great industrial and environmental importance, especially in the process system engineering. We aim at formulating the problem and overviewing the approaches developed till the present day. Also, a novel method is presented. This method is based on stochastic optimization strategy commonly referred to as adaptive random search. The paper gives the example of the method application.

SYMBOLS

$C_{s,in}^{max}$	– maximum concentration of the contaminant s in inlet stream directed to the j -th process,
$C_{s,out}^{max}$	– maximum concentration of the contaminant s in the outlet stream from the j -th process,
$C_{j,s,in}$	– concentration of the contaminant s in the inlet stream directed to the j -th process,
$C_{j,s,out}$	– concentration of the contaminant s in the outlet stream from the j -th process,
$C_{s,in}^{proc} / C_{s,out}^{proc}$	– concentration of the contaminant s in the inlet/outlet stream,
$F_{i,j}$	– flow rate of water stream from the process i to the process j ,
F_j^w	– flow rate of freshwater stream to the process j ,
$F_{j,out}$	– flow rate of water stream from the process j to central treatment station,
F_j	– flow rate of water stream in the process j ,
F^{proc}	– flow rate of process stream,
$L_{j,s}$	– mass load of the contaminant s removed in the process j ,
M	– number of water-consuming processes,
MILP	– mixed-integer linear programming,
MINLP	– mixed-integer nonlinear programming,
NLP	– nonlinear programming,
i, j, k	– subscripts,
s	– contaminant type,
T	– number of contaminants removed by water in the system.

* Rzeszów University of Technology, Department of Chemical Engineering and Process Control, al. Powstańców Warszawy 6, 35-959 Rzeszów, Poland, tel. (48)(17) 8651380, fax. 48178543655, e-mail: ichjj@prz.rzeszow.pl.

1. INTRODUCTION

Water is applied in many processes of various branches of industry. However, the problems of minimal use of freshwater and also minimal generation of wastewater that needs treatment seem to be of the greatest importance in chemical industry and relative branches such as food processing, pharmaceutical industry, etc. This results from the fact that many substances harmful to environment are used in such industries. The substances, called contaminants in the following, are transferred to wastewater and then have to be removed before discharging to the environment. The treatment process is expensive in terms of both investment and operation costs.

Water is indispensable to typical "chemical" processes such as extraction, stripping or distillation with steam. These are mass-exchange processes of the MSA (mass separating agent) type in which water serves as separating agent. Additionally water is necessary for washing the tanks, for various equipment, cyclones and filtration. Great volumes of make-up water are used in steam boilers and in cooling towers, the components of utility subsystem, which is, in turn, a part of chemical plant.

Independently of treatment efficiency, the quality of water deteriorates before its discharge to environment. Hence, minimizing the water usage in process systems is of great environmental and economic importance.

The core of modern "philosophy" of clean, environmental-friendly industrial production is to replace the end-of-pipe processing with elimination of waste at its source, i.e. during technological processes. In the case of water, our basic aim should be the minimization of water usage in industrial system. More precisely, the main goal is to minimize the freshwater usage (by freshwater we mean the water taken from natural resources such as rivers, lakes). This allows us to reduce the production of wastewater (i.e. water subjected to final treatment before its discharge to natural sources) and the cost of water treatment, which usually is proportional to the flow rate of wastewater to be treated.

A proper design and application of water-consuming processes and treatment apparatuses are of a prime importance. However, advanced technologies and modern equipment are far from being perfect and it is rather difficult to achieve the goals presented above. Some noticeable improvement of wastewater treatment can be made by optimization of water network structure, i.e. network involving both water-consuming processes and treatment units. Ultimately, zero discharge, i.e. closed water cycle, can be reached.

In order to reach a substantial reduction in freshwater consumption, the following measures should be implemented:

- water re-use in water-consuming processes,
- redistribution of water-treatment units.

In the majority of industrial plants, the process water is used in parallel arrangement, i.e. it is supplied to each unit that requires water. Next, the used water from each unit is directed to a central treatment station shown schematically in figure 1.

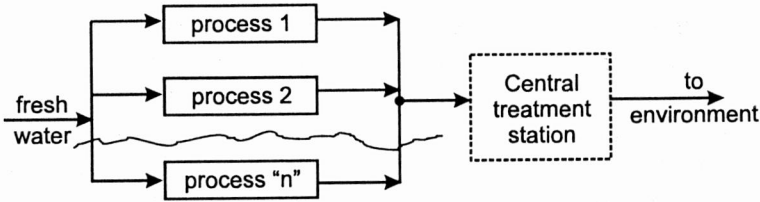

Fig. 1. Water network with parallel arrangement of process and central water station

The water-consuming processes, pipe network (i.e. mixers and splitters) and treatment processes are called the water network (WN), or the water treatment network (WTN). The water network shown in figure 1 consists of a treatment station and the parallel pipes supplying units of equipment with freshwater. It is clear that such a network requires large amounts of freshwater and generates large amounts of wastewater for treatment. In order to reduce the volume of freshwater, it can be reused, i.e. applied for the second time in another process. This is the water network with reuse (WN-R) shown schematically in figure 2. The WN-R also has a centralized water-treatment station.

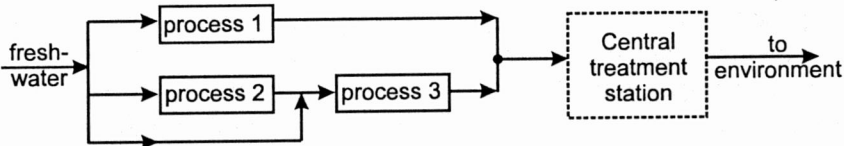

Fig. 2. Water network with reuse and central treatment station

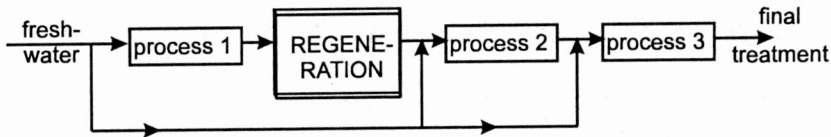

Fig. 3. Water network with distributed treatment processes – regenerators without recycling

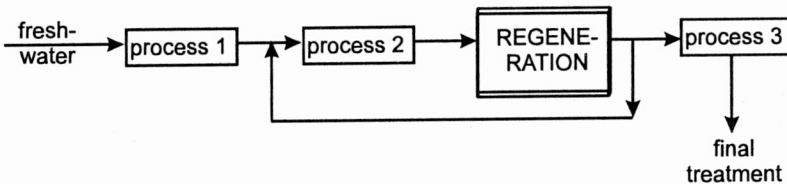

Fig. 4. Water network with distributed treatment processes – regenerators with recycling

Further improvement of the efficiency of treatment central station can be achieved by its decentralization, which is illustrated by figures 3 and 4. Treatment units in the network

are commonly termed "regenerators" to discriminate between them and the units in final treatment station. Some authors present two cases of regeneration: regeneration without recycles (figure 3) and regeneration with recycles (figure 4). In the former, the water after regeneration cannot be applied in the processes, where it was used before.

In the decentralized water treatment processes and in the case of water reuse, a closed cycle of process water is possible. This enables elimination of water discharge into environment. Freshwater is necessary only for supplementing the loss of water in the system. It is very difficult to reach a zero discharge of water. It also seems to be an expensive solution or even uneconomic because of, e.g., cumulation of solid deposits. However, zero discharge is the best solution in terms of environmental protection.

Independently of the application of closed cycles of water it is necessary to minimize the freshwater usage by water reuse and implementation of regenerators. The problem, considered recently in the literature on chemical and process engineering, is profound, hence researchers try to solve it by minimization of total cost of water and treatment network. The costs of water transportation and treatment as well as the costs of apparatus and piping should also be taken into account.

In this paper, we describe the methods of designing water networks with reuse and centralized treatment station, i.e. WN-R, with a special attention being paid to minimum freshwater usage. In the following sections, we present mathematical model of water-using processes and methods of designing an optimal WN-R proposed in the literature. The method developed by us based on stochastic optimization as well as an example are given.

2. MATHEMATICAL MODEL OF WATER-USING PROCESSES

In order to develop a general optimization model for water network design, we assume that all water-consuming processes are treated as counter-current mass exchangers. The scheme of an exchanger is shown in figure 5. It is supposed that in the process there is a stream (process stream) from which water removes some substances, called "contaminants", and that we know:

- total mass flow-rate (F^{proc}) of the stream,
- contaminants to be removed ($s \in T$) from the stream,
- initial concentration (mass fraction) of contaminants ($C_{s,\text{in}}^{\text{proc}}$) in the stream for $s \in T$,
- required final concentrations (mass fraction) of contaminants ($C_{s,\text{out}}^{\text{proc}}$) for $s \in T$.

Based on the above data we can calculate from equation (1) mass loads of contaminants that have to be removed from process stream:

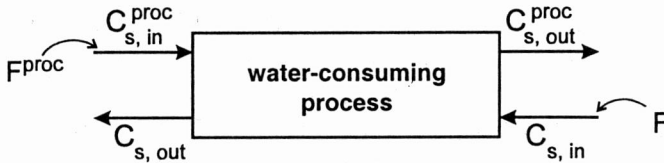

Fig. 5. Scheme of mass exchange process – model of water-consuming process

$$L_s = F^{\text{proc}} (C_{s,\text{in}}^{\text{proc}} - c_{s,\text{out}}^{\text{proc}}), \quad s \in T. \quad (1)$$

Since mass loads of contaminants are very small, a constant flow-rate of the process stream in equation (1) can be accepted.

Besides mass loads of contaminants ($L_s; s \in T$) we have to know the boundary, maximal concentrations of contaminants in water at the inlet to and outlet from each process unit. In the process with typical mass exchanger, the maximal concentrations of contaminants can be estimated from thermodynamic equilibrium conditions, in this case, however, some correction that takes account of the process dynamics is necessary. For instance, if the concentration in the equilibrium is C^* , we assume that $C = C^* - \varepsilon$, where ε is a small value. It is worth noting that such a way of modelling mass exchangers is applied in designing typical mass exchanger networks such as networks enabling extraction, stripping and so on, see [1]. In the case of other types of water-consuming processes, the maximum concentrations of contaminants can be estimated on the basis of:

- boundary value of contaminant solubility in the water,
- corrosion limitation,
- other technological conditions such as fouling.

If the mass loads of contaminants and maximum concentrations of contaminants in water streams at inlet and exit of process units are known, the mathematical model of water-consuming process is defined as:

$$L_s = F(C_{s,\text{out}} - C_{s,\text{in}}), \quad s \in T, \quad (2)$$

$$C_{s,\text{in}} \leq C_{s,\text{in}}^{\text{max}}, \quad s \in T, \quad (3)$$

$$C_{s,\text{out}} \leq C_{s,\text{out}}^{\text{max}}, \quad s \in T. \quad (4)$$

In the above case, we assume a constant water flow rate, which is acceptable because of low concentration of contaminants.

Summing up, to formulate and to solve the mathematical model of water-consuming process, we have to know the mass loads of contaminants being removed ($L_s; s \in T$) as well as the maximal contaminants concentrations in the water at inlet to and outlet from a process unit ($C_{s,\text{in}}^{\text{max}}, C_{s,\text{out}}^{\text{max}}$ for all $s \in T$).

It is clear that the assumptions commonly accepted in mathematical model of water network are restrictive. A possibility of estimating exact values of necessary data, especially the maximum concentrations, can be discussed in some cases. However, one should take into account that the integration of water network has to be made at initial stage of its design. The integrated network is modified in the following stages of process design using simulation calculations for more rigorous models of processes. However, for the simulation calculations, the structure of the water network calculated on the integration level should be known.

3. PINCH METHOD

The model of water-consuming process is sufficient to integrate the water network using the methods that are based on the pinch concept. The pinch concept was first applied to the analysis of heat-energy integration in chemical systems and to the design of optimal heat exchanger networks (HEN). Then, it was also used for the synthesis of mass exchanger network (the networks consisting of typical mass exchangers such as extractors, stripping towers and so on). Pinch-based methods are widely applied in the industry and can be found in numerous papers and monographs, for instance [1]–[4]. It should be stressed that both heat and mass integration yield waste reduction in chemical industry. In this work, we describe briefly the pinch method application to integration of water network. A problem of minimization of freshwater consumption in the water network with central treatment station (figure 2) will be considered. Additionally, we assume that only one contaminant is removed. Pinch method can also be applied in the removal of numerous contaminants, but in such a case computations are rather complex. Graphical representation of the method considered as its important advantage is not useful for the latter case.

The pinch method will be described based on a simple example given in [5]. In an industrial system, four water-consuming processes take place. For each process the mass loads of a contaminant and the maximal values of its inlet and outlet concentrations in water streams are given in table 1.

Table 1

Data in the example of pinch method (after [5])

Process	m [kg/h]	C_{in}^{max} [ppm]	C_{out}^{max} [ppm]
1	2	0	100
2	5	50	100
3	30	50	800
4	4	400	800

On the basis of these data the curve representing the concentration of contaminant vs. its mass load (i.e. concentration profile) (figure 6) is plotted for each process. We assume a linear character of this dependence because of low contaminant concentrations in majority of processes.

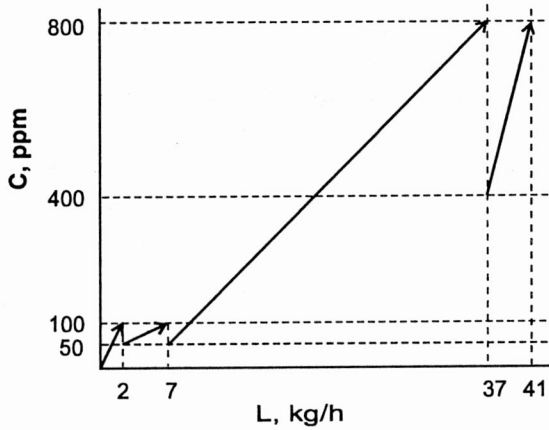

Fig. 6. Concentration profiles for the processes in the example of pinch method

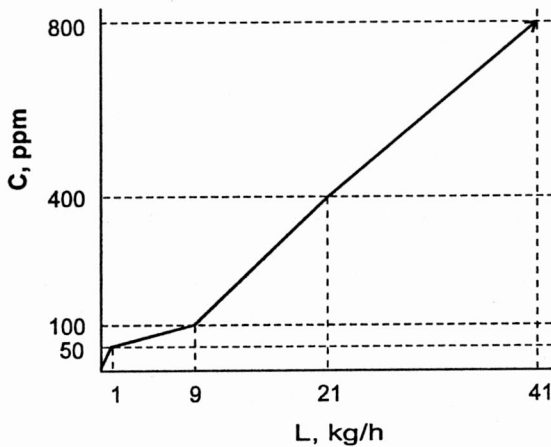

Fig. 7. Composite curve for the example of pinch method

It is worth noting that the tangent of an angle of inclination of each concentration profile defines mass flow-rate of water in each process (see formula (2)). Then, the so-called “composite curve” is constructed from the concentration profiles of the processes. The composite curve shows the dependence of contaminant concentration on mass load for all the processes combined together (figure 7). This curve consists of segments of various slopes. The slope of the segment, i.e. the tangent of the angle of

inclination of the segment, defines a minimum freshwater requirement in an appropriate range of contaminant concentration. However, these minimum values have no practical meaning, since we are not able to obtain them in real water networks. All water-consuming processes have to be designed so as to follow concentration ranges from the composite curve.

A straight line of the same slope with the whole concentration range of all processes (it starts at the point of an initial contaminant concentration in the freshwater set at 0.0 in the example) defines the minimum mass flow-rate of freshwater that can be reached in practice. The line has to be tangent to the composite curve in at least a single point, which ensures the minimum freshwater consumption. This line is termed as a freshwater supply line (WSL). The construction of WSL is illustrated in figure 8.

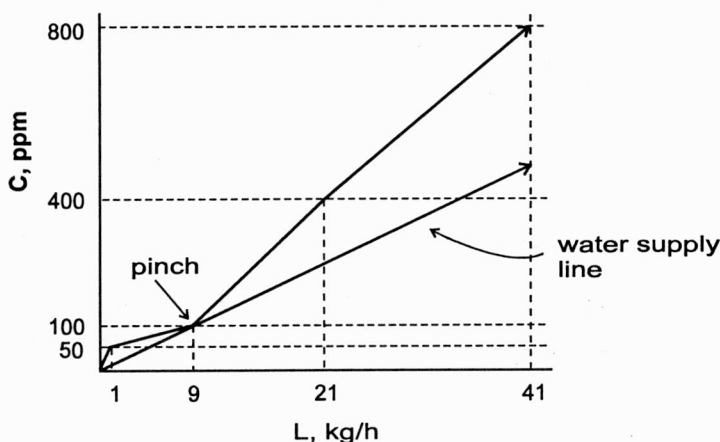

Fig. 8. Water supply straight line for the example of pinch method

Due to such a construction of WSL the following conditions are fulfilled:

1. The concentrations of contaminants in water in each process do not exceed the maximum values of C_{in}^{max} and C_{out}^{max} .

2. Rate of flow of total freshwater is minimum because of maximization of angle of inclination of WSL at constraints (3), (4).

The point of contact of WSL with the composite curve is called the *pinch*, since it limits further decrease in the freshwater consumption (the value of the tangent of an angle of inclination of WSL cannot be higher, because otherwise WSL intersects the composite curve, and the conditions (3), (4) will not be valid any longer).

In the example, the value of the minimum mass flow-rate of freshwater calculated from the WSL is 90 t/h. It is worth noting that in the case of the parallel arrangement of processes without water reuse, the value of freshwater consumption is 112.5 t/h (see [5]). Hence, the reuse of water makes the reduction of the freshwater by 22.5 t/h possible.

In order to decrease a further freshwater consumption, one has to apply a decentralized treatment scheme, i.e. regenerators within water network. Authors [6] showed that due to water reuse and regenerators (without recycles) the freshwater consumption in the example can be as low as 46.2 t/h (see also figure 9).

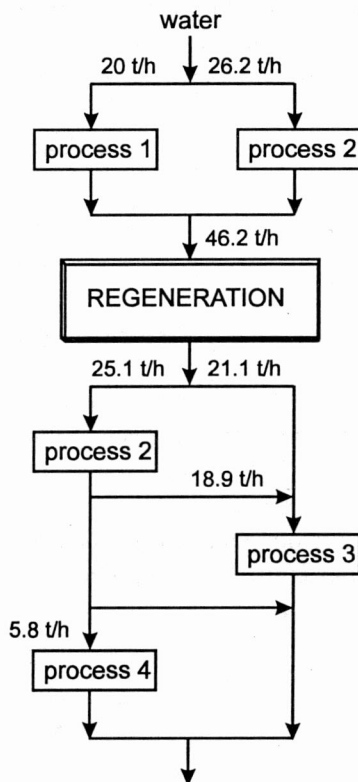

Fig. 9. Water network with the minimum freshwater consumption designed by authors [6]

The pinch method allows designing a water network with minimum water consumption. This problem, however, will not be considered in our paper. Moreover, the pinch method does not guarantee the optimum network. The optimum water network with water reuse and regenerators for the above example designed by [5] is shown in figure 9.

The pinch method is simple and can be easily understood by industrial practitioners, hence, it is applied in practice, see, e.g., [7], [8]. Commercial program of Water Pinch of Linnhoff March based on the pinch method is available and allows engineers to design water networks.

4. OPTIMUM DESIGN OF WATER NETWORK WITH REUSE BY MEANS OF OPTIMIZATION METHODS – BASIC CONCEPTS

The water network design by means of optimization methods, on the assumption that the network contains central treatment station, is presented. However, water reuse is accounted for. In order to optimize the methods, we ought to optimize a superstructure, i.e. the structure that comprises all potential connections of water-consuming processes. Hence, the superstructure contains also an optimal structure that has to be found.

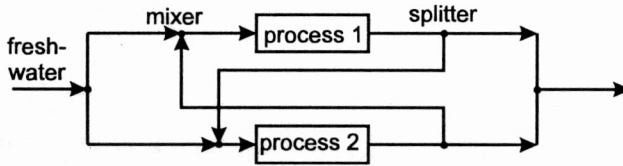

Fig. 10. Example of the superstructure with two water-consuming processes

The water network consists of mixers and splitters. The superstructure is a series connection of mixer–water-consuming process $j \in M$ –splitter (compare figure 11). Each mixer assigned to the process j is supplied with the freshwater and with water streams from splitters connected to the processes $i \neq j, j \in M$. Additionally, one water stream from each splitter is directed to the processes $i \neq j, j \in M$. The example of the superstructure for two processes is shown in figure 10.

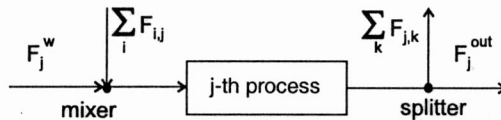

Fig. 11. Arrangement of mixer–process splitter in the superstructure – illustration of balances A in the optimization model

It is assumed that the designer is able to estimate the data for all water-consuming processes in a chemical complex. For each process the loads of contaminants and the maximum values of concentrations at inlet and outlet have to be given.

The mathematical model of the superstructure has to involve models of water-consuming processes, mixers and splitters. The optimization model for water network with reuse (WN-R) synthesis has been built on the basis of papers [9]–[14] whose authors assumed that:

- there is a single source of freshwater,
- concentrations of all contaminants in the freshwater are equal to zero,
- there is no loss nor generation of water in any process.

5. DEFINING THE PROBLEM OF WATER NETWORK INTEGRATION. BASIC MODEL

Data:

$$L_{j,s} \text{ for } j \in M, s \in T,$$

$$C_{j,s,in}^{\max} \text{ for } j \in M, s \in T,$$

$$C_{j,s,out}^{\max} \text{ for } j \in M, s \in T.$$

Goal function

$$\min \sum_{j \in M} F_j^w \tag{5}$$

is subject to

A) mass balances for the arrangements: mixer-process-splitter (see figure 11)

$$F_j^w + \sum_i F_{i,j} - \sum_k F_{j,k} - F_{j,out} = 0, \quad j \in M; \tag{6}$$

B) mass balances of contaminants for processes (see figure 12)

$$L_{j,s} - \left(F_j^w + \sum_i F_{i,j} \right) \cdot C_{j,s,out} + \sum_i F_{i,j} \cdot C_{i,s,out} = 0, \quad j \in M, s \in T; \tag{7}$$

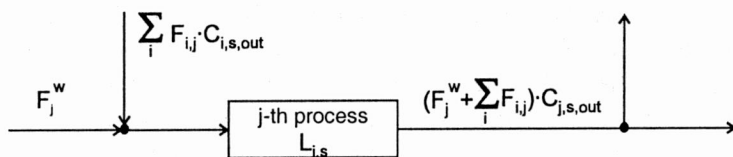

Fig. 12. Illustration for mass balances B in the optimization model

C) mass balances of contaminants in mixers (see figure 13)

$$\sum_i F_{i,j} \cdot C_{i,s,out} - \left(F_j^w + \sum_i F_{i,j} \right) \cdot C_{j,s,in} = 0, \quad j \in M, s \in T. \tag{8}$$

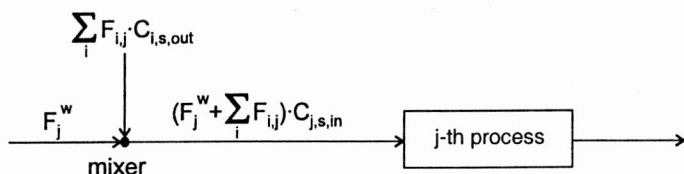

Fig. 13. Illustration for mass balances C of mixers in the optimization model

Besides the above mass balances, the admissible maximum inlet and outlet concentrations of contaminants in each process have to be assessed:

$$C_{j,s,in} \leq C_{j,s,in}^{\max}, \quad (9a)$$

$$C_{j,s,out} \leq C_{j,s,out}^{\max}. \quad (9b)$$

6. ANALYSIS OF THE OPTIMIZATION PROBLEM AND METHODS OF ITS SOLUTION

Optimization of the water network integration is a nonlinear problem (NLP) with continuous variables. For T contaminants and M water-consuming processes the number of variables is given by equation (10). The number of constraints is given by equation (11):

$$LZ = M \cdot (2 + 2 \cdot T + (M - 1)), \quad (10)$$

$$LO = M \cdot (2T + 1). \quad (11)$$

To show the dimensionality of the optimization problem let us consider the case with $M = 10$ and $T = 3$. The number of parameters is equal to 170 and the number of constraints – to 70.

It can be concluded that the problem of water network integration is complex because of a large number of variables. Also a large number of the constraints imposed on equations is the source of difficulties with solving the optimization problem. The NLP (nonlinear programming) problems, independently of the number of variables and constraints in equation, are difficult to solve, especially if a global optimum has to be found.

The optimization approaches to water network integration described in literature are classified as follows:

- methods applying directly mathematical programming without any simplifications of nonlinear problem and with no sequential calculations – direct optimization methods,
- methods applying optimization but in an indirect way, i.e. by simplifications of nonlinear optimization problem and by means of some sequential procedure – indirect optimization methods.

We present here only a brief review of optimization methods developed for the WN-R synthesis. The “direct” optimization approaches were described among others in [15]–[18]. They were mainly based on deterministic mathematical programming methods. The authors of [15], [16] presented the solution of exemplary problems by means of GAMS [19]. In paper [18], a stochastic optimization strategy, namely genetic algorithm, was adopted. The method allowed solving industrial, large-scale problem.

Indirect approaches to WN synthesis were developed mainly by Professor BAGAJEWICZ and his coworkers, see [9]–[14]. Their major concept arises from such a simplification of nonlinear optimization problem as to arrive at linear one. This transformation was possible, because they proved (see [11]) that it was the maximum outlet concentrations of contaminant in water streams that was responsible for minimizing the freshwater consumption. With the outlet concentrations fixed at the maximum values, the nonlinear optimization problem of freshwater minimization can be rigorously formulated as a linear one, see [9], [12], [14]. However, it is necessary to stress that

1. In the case of more than one contaminant, the condition of maximum outlet concentration is fulfilled only for a single contaminant referred to as “key contaminant”. Outlet concentrations of other contaminants can be lower than maximum values. Since the key contaminant is not known *a priori*, one has to solve a sequence of linear optimization problems (see [12], [14]).

2. Water networks with the outlet concentration of key contaminant set at the maximum are not the only means of optimizing the freshwater consumption. There are also water networks with the minimum freshwater consumption that feature lower concentrations, called degenerate solutions in [9], [12], [14]. Such networks can be optimal in regards to more general functions such as, e.g., total cost.

3. If minimization of freshwater consumption is the only performance criterion (which is necessary for the indirect method of Bagajewicz and coworkers), a sequential procedure for water network designing should be adopted, with some additional criteria being included. For instance, if the minimum freshwater consumption and the minimum of interconnections in the WN are sought, one has to solve first the problem of freshwater minimization and then the problem of minimization of interconnection number. The latter is of MILP type, i.e., involves both continuous and binary variables and requires optimization.

This short review of WN synthesis approaches developed until now showed that in spite of a significant progress the optimization approaches still suffer from drawbacks. The direct optimization methods do not ensure a global optimum and require sophisticated solutions. The indirect approaches do not guarantee the global optimum either. Hence, further development and improvement of WN design methods are necessary.

In the next section, we describe a new approach to the integration of water network by means of stochastic optimization.

7. INTEGRATION OF WATER NETWORK BY ADAPTIVE RANDOM SEARCH

Adaptive random search (ARS) is one of the oldest stochastic optimization strategies. The authors of this paper have for several years applied one of modifications of ARS, called LJ algorithm (LJ stand for the names of Luus and Jaakola who developed it [20]). Our investigations proved a high reliability of the algorithm in calculating the

global optimum, especially in the cases of small- and medium-size NLP problems. Examples of LJ algorithm applications in the problems of chemical and process engineering optimization can be found in papers [21]–[24]. The LJ algorithm is presented in detail in [20], [21], [23] and, hence, we describe its basic concepts.

In order to calculate the independent variables, the generators of pseudorandom variables of uniform distribution are applied. Hence, the first crude modifications of ARS approach were commonly called Monte Carlo methods. In ARS approaches, the value of each decision variable is calculated in such a way as to ensure an increased probability of its sampling in some neighbourhood of the point $X^* \in R^n$, where X^* is the best current solution. In the LJ algorithm, this is mainly achieved by a successive limiting the regions, where variables are sampled.

ARS methods are easy to apply in the case of optimization problems without constraints imposed on equations. If such constraints exist, e.g. in WN synthesis problem, the most efficient solution is to divide variables into dependent (state) variables and independent (decision) ones. The former variables are calculated from the constraints. Such a way of dealing with the constraints allows reducing dimensionality of optimization problem. The choice of decision variables is a key factor, since it influences a possibility of solving constrained optimization problem. The basic condition is to obtain linear equations in regards to dependent variables. Such equations can have the form of set of equations being solved either simultaneously or sequentially.

In the case of WN optimization problem, non-linearities are in mass balances of contaminants (7), (8) and are caused by products of mass flow-rates and concentrations – bilinear terms. Based on the analysis of WN optimization problem, mass flow rates of water streams were chosen as the decision variables. Hence, the rest of parameters in the model become dependent variables that are calculated from linear constraints. The linear constraints were arranged in blocks of equations being solved in sequential manner and set of simultaneous linear equations. The detailed description of the solution procedure will be addressed in a separate paper.

Summing up, the above choice of decision variables reduces the dimensionality of WN optimization problem to the number of degrees of freedom. Furthermore, the dependent variables are calculated from linear equations.

The solution procedure was coded in the simulation system of optimization program of OPTI-STO described in [23]. We developed this program as the tool for solving general NLP/MINLP optimization problems. ARS optimization approach is one of optimization procedures besides simulated annealing method, which is available in OPTI-STO.

Several examples of the problem of water network integration found in literature have been solved until now. The examples showed up to six water-consuming processes with a one or more contaminants. In all cases, we obtained the solutions that are considered optimal in the literature.

In the following, we present in detail one of the examples.

8. EXAMPLE

The example found in [5] is presented because of its vital practical importance. It deals with water network in a typical chemical plant. The flow sheet in figure 14 shows processes of interest in chemical and utility subsystems. The single block called "chemical processes" shows only symbolically chemical processes. They are shown in more detail in figure 15. In the utility subsystem, water is used as make-up water in boiler and in cooling tower.

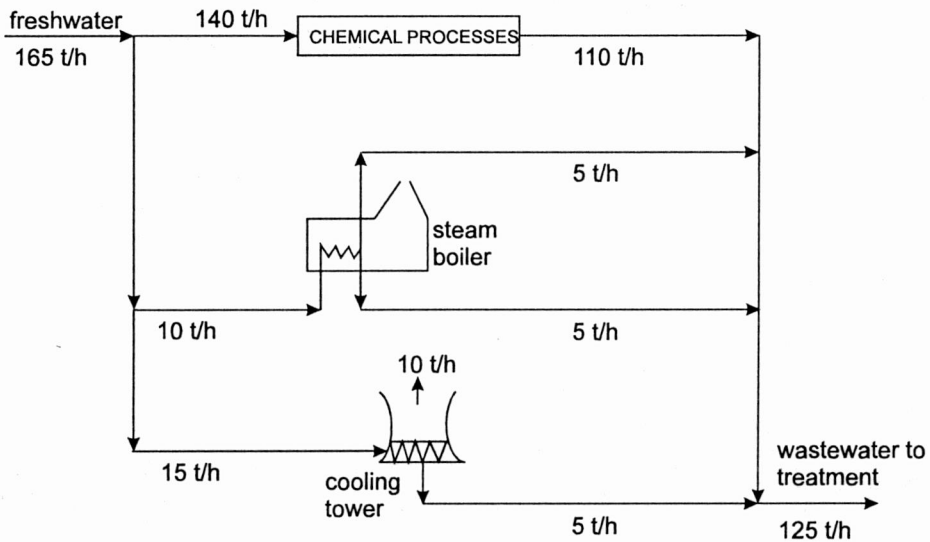

Fig. 14. General flow-sheet of chemical plant for the example considered

Chemical using-water processes of interest are as follows:

- chemical reaction in water environment,
- sedimentation process, where solid phase is separated,
- cyclone, where solid phase formed due to sedimentation is concentrated and washed with water,
- filtration, where water is used to wash filtration cake.

In this factory, water network of parallel structure with central water treatment station is applied. The freshwater consumption amounts to 165 t/h, while the flow rate of wastewater used for treatment processes is equal to 125 t/h. The major contaminant that limits reuse of water in all processes is suspension of solids. Hence, this suspension is treated as the only contaminant of water streams.

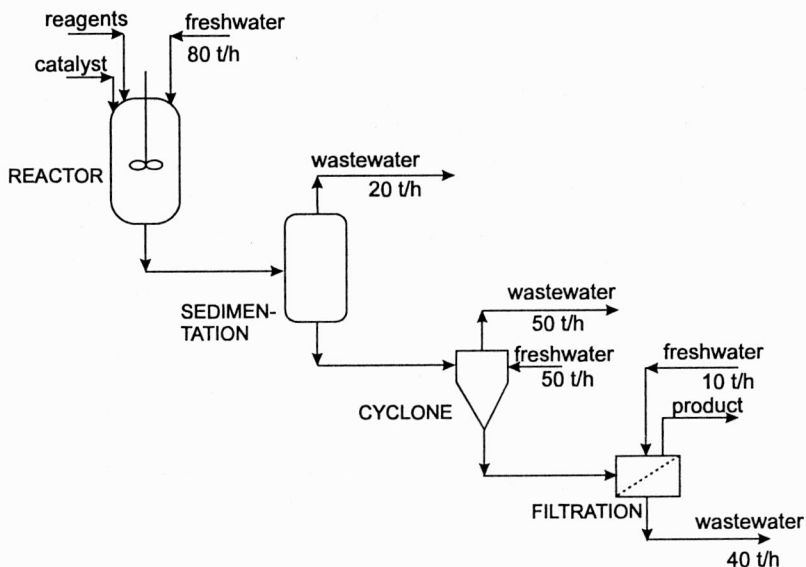

Fig. 15. Chemical processes in chemical plant from figure 14

Table 2

Data for water-consuming processes in real process system (after [5])

Process/apparatus	Inlet water stream (t/h)	Outlet water stream (t/h)	C_{in} (ppm)	C_{out} (ppm)
Reactor	80	20	0	900
Hydro-cyclone	50	50	0	500
Filtration	10	40	0	100
Steam boiler	10	10	0	10
Cooling system	15	5	0	90

In table 2, the results that are important for water-using processes are gathered. It is worth noting that in certain processes we deal with water loss or water, i.e.

- water loss of 60 t/h in chemical reaction,
- water loss of 10 t/h in cooling tower,
- 30 t/h of water is generated in filtration.

Because of the operating conditions in all processes the flow rates of water streams have to be the same as in existing system (see table 2 and table 3). Water can be reused repeatedly, provided that the maximum values of contaminant concentration in water at the inlet will be appropriately chosen. Based on process analysis authors of [5] proposed the values given in table 3. The maximum values of the outlet concentrations were calculated so as to meet mass balances for the processes. The final data for the example is gathered in table 3.

Table 3

Data for water network design (after [5])

Process/apparatus	Inlet water stream (t/h)	Outlet water stream (t/h)	C_{in} (ppm)	C_{out} (ppm)
Reactor	80	20	100	1000
Hydro-cyclone	50	50	200	700
Filtration	10	40	0	100
Steam boiler	10	10	0	10
Cooling system	15	5	10	100

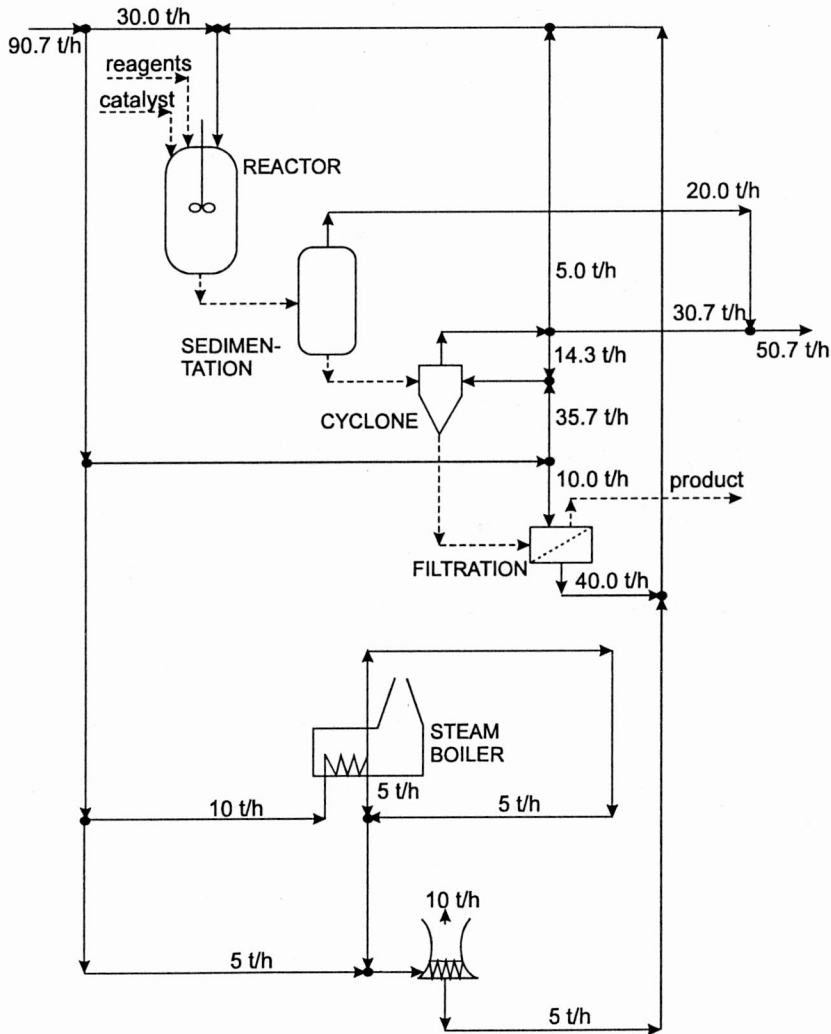

Fig. 16. Water network for the example according to authors [5]

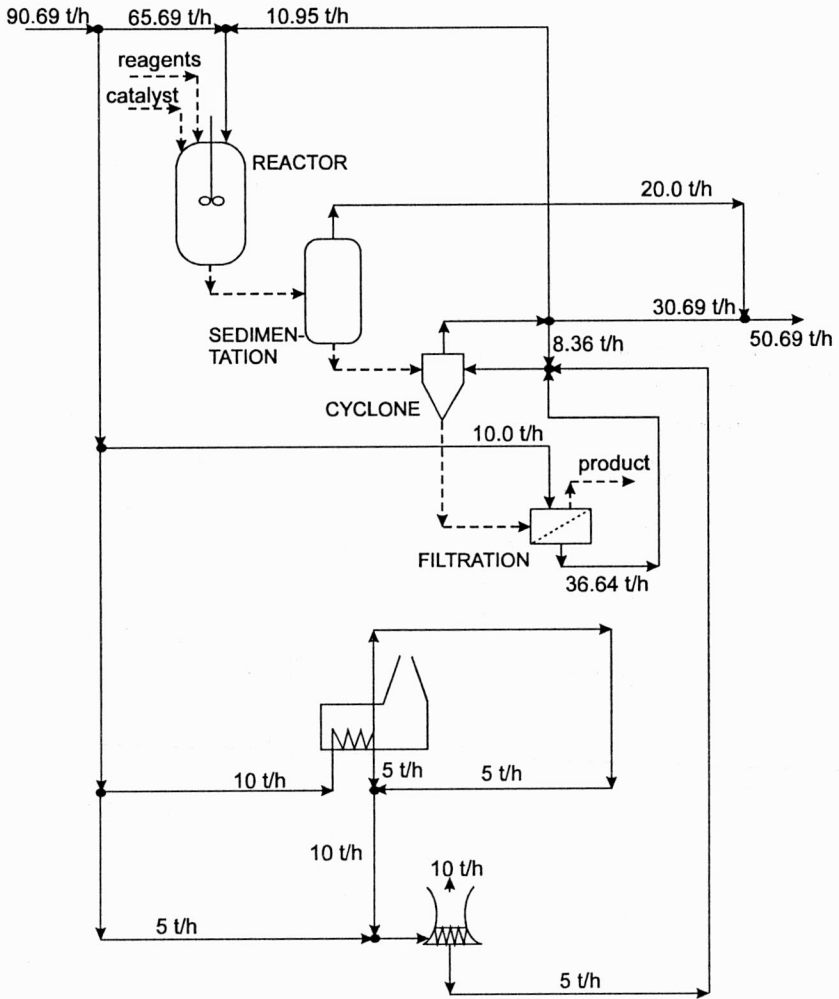

Fig. 17. Water network for the example calculated by means of ARS approach

The integration problem in the example requires certain changes in basic optimization model presented in section 5. We have to take into account the conditions that determine the water flow rates in the processes. Also mass balances were modified to account for water losses and water generation. It should be stressed that the modified optimization model can be developed according to the procedure which was used for designing the basic model by means of ARS method. This is a significant advantage of direct optimization approaches and our ARS method as well. In the case of other optimization methods such as indirect approaches or pinch method, some changes in the basic optimization model call for additional, often difficult to perform, changes in a solution procedure.

Figure 16 shows the water network calculated by pinch method in paper [5]. Dashed lines represent the process streams that do not exist in the optimization model, while solid lines – the water streams of interest. The concentration of the freshwater in comparison to parallel scheme is reduced from 165 t/h to 90.7 t/h. It is important to note that the network contains 12 interconnections. The number of interconnections influences both operation cost and control properties. Authors of [5] reported that the freshwater consumption could be increased by 5 t/h if the water from cooling tower, which likely contained some corrosion products, was not fit for use in reactor.

The above example was also solved by ARS optimization method developed by us. The freshwater consumption was accepted as an optimality criterion. Additionally we eliminated the interconnections with water flow rates lower than 2 t/h. Such interconnections are expensive in regards to investment and operation cost as well. The network calculated using ARS approach allows the freshwater consumption similar to that calculated by authors of [5], i.e. 90.69 t/h. The networks involve also 12 interconnections, but the structure of the water is different as shown in figure 17. It is worth noting that the water from a cooling tower is not directed to the reactor, hence there are no corrosion products in the reactor water. Thus, the minimum freshwater consumption in our system cannot increase if corrosion products are not allowed in reaction.

9. SUMMARY AND CONCLUSIONS

Minimization of water consumption in process systems is of a great environmental and economical importance. Apart from improvements in water-consuming processes and in water-treatment processes, the structural optimization of water networks in industrial complex should be applied to reach a minimum freshwater consumption.

The problem of optimal water network design is formulated in the paper. Brief overview of the solution methods developed so far prove that there is a need for developing a general approach that will allow us to deal with complex large-scale industrial problems. The authors developed a direct optimization method based on adaptive random search optimization. The approach applied to several problems known from literature allowed reaching an optimum freshwater consumption. The solution of an industrial case study from [5] is described in this paper.

The optimization approach developed can be considered as an efficient, easy to use technique for water network integration with extended economical goal function. The example presented in the paper proves that the adaptive random search optimization is flexible enough to allow us to overcome certain limitations often met in industrial practice. The investigations are continued in order to take into account total cost of water networks and more rigorous models of processes.

REFERENCES

- [1] EL-HALWAGI M.M., *Pollution prevention through process integration*, Academic Press, San Diego, 1997.
- [2] SMITH R., *Chemical process design*, McGraw-Hill, New York, 1995.
- [3] SHENOY U.V., *Heat exchanger network synthesis*, Gulf Publishing Company, Houston, 1995.
- [4] JEŻOWSKI J., *Projektowanie podsystemów odzysku ciepła w warunkach pewnych danych*, Oficyna Wydawnicza Politechniki Rzeszowskiej, Rzeszów, 1995.
- [5] WANG Y.P., SMITH R., *Wastewater minimization with flow rate constraints*, Trans. I. Chem. E., 1995, 73, Part A, 889–904.
- [6] WANG Y.P., SMITH R., *Wastewater minimization*, Chem. Eng. Sci., 1994, 49(7), 981–1006.
- [7] DHOLE R.V., RAMCHANDANI N., TAINSH R.A., WASILEWSKI M., *Pinch technology can be harnessed to minimize raw-water demand and wastewater generation alike*, Chem. Engng., 1996, January, 100–103.
- [8] BAETENS D., TAINSH R.A., *Towards an efficient water management strategy: Vito's integrated approach*, Paper H2.8, International Congress of Chemical and Process Engineering CHISA 2000, Prague, Czech Republic.
- [9] SAVELSKI M.J., BAGAJEWICZ M.J., *A new algorithmic design procedure for the design of water utilization systems in refineries and process plants*, Proceedings of Press'99, May 31–June 2, 1999, Budapest, Hungary, 577–582.
- [10] SAVELSKI M.J., BAGAJEWICZ M.J., *Design of water utilization systems in process plants with a single contaminant*, Waste Management, 2000, 20, 659–664.
- [11] SAVELSKI M.J., BAGAJEWICZ M.J., *On the optimality conditions of water utilization systems in process plants with single contaminants*, Chem. Eng. Sci., 2000, 55, 5035–5048.
- [12] BAGAJEWICZ M.J., *A review of recent design procedures for water networks in refineries and process plants*, Comput. Chem. Engng, 2000, 24, 2093–2113.
- [13] BAGAJEWICZ M.J., RIVAS M., SAVELSKI M.J., *A robust method to obtain optimal and sub-optimal design and retrofit solutions of water utilization systems with multiple contaminants in process plants*, Comput. Chem. Engng, 2000, 24, 1461–1466.
- [14] SAVELSKI M.J., BAGAJEWICZ M.J., *On the use of linear models for the design of water utilization systems process plants with a single contaminant*, Trans. I. Chem. E., 2001, 79 Part A, 1–10.
- [15] BENKŐ N., RÉV E., SZITKAI Z., FONYÓ Z., *Optimal water use and treatment allocation*, Comput. Chem. Engng, 1999, 23 Suppl., S157–S160.
- [16] HUANG C.H., CHANG C.T., LING H.C., CHANG C.C.A., *Mathematical programming model for water usage and treatment network design*, Ind. Eng. Chem. Res., 1999, 38, 2666.
- [17] TEKAMA N., KURIYAMA T., SHIROKO K., UMEDA T., *Optimal water allocation in petroleum refinery*, Comput. Chem. Engng, 1980, 4, 251.
- [18] TSAI M.-J., CHANG C.-T., *Water usage and treatment network design using genetic algorithms*, Ind. Eng. Chem. Res., 2001, 40, 4874–4888.
- [19] BROOKE A., KENDRICK P., MEERAUS A., *GAMS. A users guide. Release 2.25*, The Scientific Press Series, 1992.
- [20] LUUS R., JAAKOLA T.H.I., *Optimization by direct search and systematic reduction of the size of search region*, AIChE Journal, 1973, 19(4), 760–766.
- [21] JEŻOWSKI J., BOCHENEK R., *Optymalizacja metodą adaptacyjnego przeszukiwania losowego w projektowaniu procesów. I. Opis metody optymalizacji*, Inżynieria Chemiczna i Procesowa, 2000, 21, 443–463.
- [22] BOCHENEK R., JEŻOWSKI J., *Optymalizacja metodą adaptacyjnego przeszukiwania losowego w projektowaniu procesów. II. Przykłady zastosowań w inżynierii procesowej*, Inżynieria Chemiczna i Procesowa, 2000, 21, 465–487.

- [23] JEZOWSKI J., BOCHENEK R., *Experiences with the use of the Luus–Jaakola algorithm and its modifications in optimization of process engineering problems*, chapter [in:] R. Luus (ed.), *Recent Developments in Optimization and Optimal Control in Chemical Engineering*, to be published by Research Signpost.
- [24] BOCHENEK R., JEZOWSKI J., *Adaptive random search approach for retrofitting flexible heat exchanger networks with fixed topology*, Hung. J. Ind. Chem., 1999, 27(2), 89–97.

OPTYMALIZACJA ZUŻYCIA WODY W INSTALACJACH PRZEMYSŁU CHEMICZNEGO

Opisano projektowanie sieci wody procesowej w przemyśle chemicznym i gałęziach pokrewnych. Sieć wody procesowej składa się z systemów zużywających wodę oraz z systemów jej oczyszczania. Celem projektanta jest stworzenie takiej sieci, która zużywałaby minimalną ilość świeżej wody. Ma to wielkie znaczenie zarówno ekonomiczne, jak i ekologiczne. Podstawowe cele pracy są następujące: sformułowanie problemu i krótki przegląd metod jego rozwiązania. Opisano także nową metodę projektowania sieci wody użytkowej. Metoda opiera się na optymalizacji stochastycznej, tzw. strategii adaptacyjnego przeszukiwania losowego. Podano przykład zastosowania tej metody.

