

# **Influence of stimulated Mandelstam–Brillouin scattering on the time parameters of Nd:YAG laser pulse**

J. MARCZAK, A. RYCYK, M. SZCZUREK

Kaliski Institute of Plasma Physics and Laser Microfusion, 00-908 Warszawa, P.O. box 49, Poland.

The paper describes a method of a laser pulse shaping, in which the stimulated Mandelstam–Brillouin scattering (SMBS) was used. This method when applied to a high power Nd:glass laser system yielded the pulse of a contrast ratio  $10^9$ .

## **1. Introduction**

One of the basic parameters of the laser pulse, generated by a high power laser system suitable for plasma investigation, is the contrast, i.e., the ratio of the power (or energy) of the laser pulse to that of the prepulse. The magnitude of the prepulse recorder at the output of the laser system consists of superluminescence of the amplifying stages, parasitic generation on the optical element surfaces (free generation), and the prepulse appearing due to the application of the nonperfect systems shaping the laser pulse (i.e., the cut-off systems).

The actually used cut-off systems of laser pulses of duration ranging from  $10^{-11}$  to  $10^{-8}$  s, working on the base of Pockels cells located outside the generator, assure the power contrast ratio of order of  $10^3$ – $10^4$  [1]. A simultaneous application of the high quality electrooptic switches and nonlinear absorbers allows us to obtain the contrast ratio of order of  $10^8$  [2].

The work [3] presents the experimental results of the Nd laser pulse contrast investigation in the system of one amplifier (on the neodymium glass) with the application of the SMBS mirror.  $\text{CCl}_4$  has been used as an active medium and a laser pulse contrast ratio  $4 \times 10^7$  has been obtained.

In the work [4] to enhance the contrast ratio of high power iodine laser pulse  $\text{SF}_6$  has been used as the active medium and the recorded contrast was of order of  $10^7$ . From the theoretical [5], [6] estimations it follows that the application of SMBS may give the contrast of order of  $10^9$ . In the papers [7–9] it has been pointed out that the SMBS mirror, located between the generator and the amplifiers of the high power laser, protects the system against the autoexcitation. The SMBS assures also a correction of the phase distortions due to reversal of the wave-front [10], [11].

## 2. Experiment

In the up-to-now plasma investigation the high power laser system has been applied, the generator of which together with the pulse forming system is shown in Fig. 1. From the pulse of duration  $\tau_{1/2} = 20$  ns produced in a YAG Q-switched generator with the help of the Pockels cell PC-1 a pulse of duration  $\tau_{1/2} = 3$  ns has been cut off with the help of two electrooptic switches PC-2 and PC-3 synchronized in time and space. The application of this additional Pockels cell PC-3 located in the system of double crossed dielectric polarizers DP and a nonlinear absorber NA assured the contrast ratio  $5 \times 10^5$  at the output of the high power laser system.

The preliminary experimental investigation of the stimulated Mandelstam-Brillouin scattering has been carried out in the system presented schematically in Fig. 2. The purpose of these investigations was to determine both the experimental conditions in which scattered backwards radiation may be utilized in the high power laser system and the measurement of the time-energy parameters of both incident and scattered backward pulses in the system of SMBS mirror.

The time shape of the input laser pulse after being reflected from the beam splitter BS2 was recorded by a photodiode PH2 and an oscilloscope. Next, the radiation polarized linearly in the plane of the figure passed through the dielectric polarizer DP and a quarter-wave plate  $\lambda/4$  changing the polarization to a circular one. After having passed the beam splitter BS1 the radiation was focused by the lens L in the cuvette filled with an active medium. The time shape of the pulse scattered backwards was recorded by using the photodiode PH1. Since, due to backscattering in the SMBS process, the polarization of laser radiation changes its

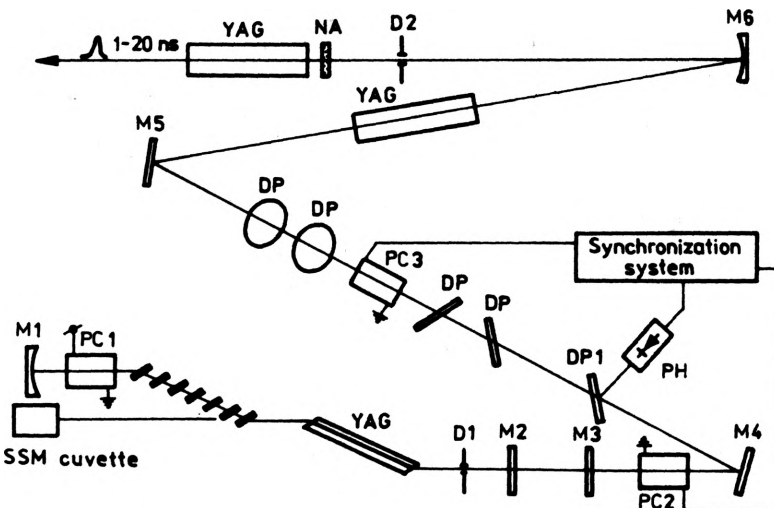

Fig. 1. Scheme of the laser generator. M1-M6 - dielectric mirrors, PC1-PC3 - Pockels cells, D1, D2 - diaphragms, PH - photodiode, YAG - laser head with an active medium YAG:Nd<sup>3+</sup>, DP - dielectric polarizer, NA - nonlinear absorber, (SSM - selfsynchronization of modes)

sign to the opposite one, then after the second passage through the quarter-wave plate  $\lambda/4$  the radiation is polarized perpendicularly to the polarization plane of the input pulse. The laser pulse polarized in such a way was subject to total reflection from the surface of the dielectric polarizer DP, and next the transverse distribution of its power density was recorded by using photographic camera.

The measurements have been carried out for two active media  $\text{CS}_2$  and  $\text{CCl}_4$  for the pulse duration ranging from 3 to 20 ns and the energy from 1 to 150 mJ for different focal length of the lens L. Since, due to the propagation of the laser pulse in the Nd:glass amplifier system, the value of the contrast ratio decreases, its value at the output of the whole high power laser system is essential. Therefore, before starting the contrast ratio measurement, the laser pulse formed in the system shown in Fig. 2 was amplified in the sequence of main amplifiers to the energy value  $E = 15 \text{ J}$ .

The contrast ratio measurement was realized in the contrast ratio measuring system (CMS) shown schematically in Fig. 3. The principle of contrast ratio measurements consists in determining the peak laser pulse power ratio to the prepulse power. The contrast ratio magnitude  $K$  was determined by using the

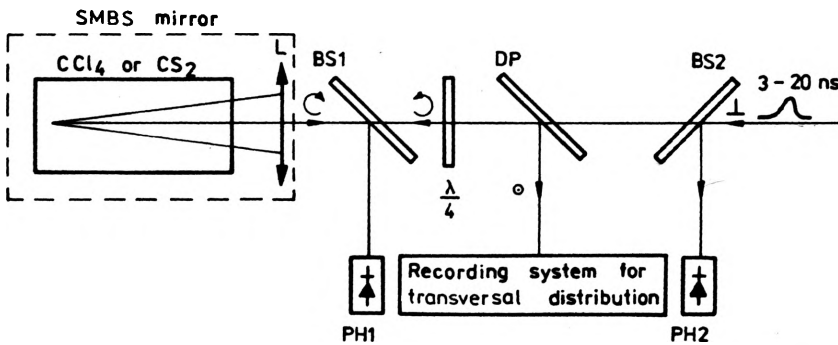

Fig. 2. Scheme of the system to SMBS mirror investigation. L – lens, BS1, BS2 – beam splitters, DP – dielectric polarizer,  $\lambda/4$  – quarter-wave plate, PH1, PH2 – photodiodes

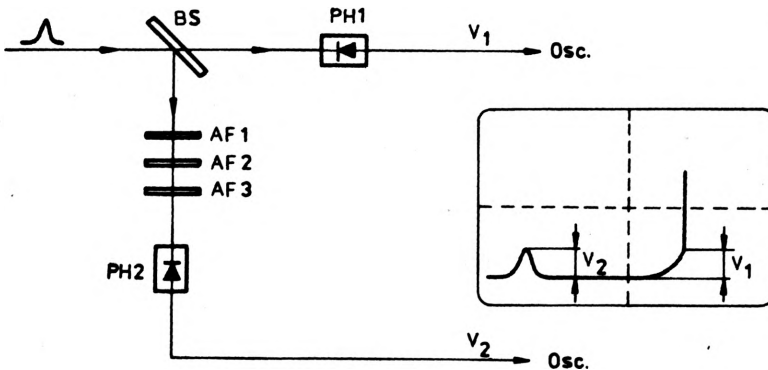

Fig. 3. Scheme of the system to measure the laser pulse contrast ratio. BS – beam splitter, AF1–AF3 – attenuating filters, PH1, PH2 – photodiodes, Osc. – oscillator input (for  $V_1$  and  $V_2$  see the text)

dependence  $K = k(V_2/V_1)$ , where:  $V_1, V_2$  – prepulse and pulse amplitude, respectively,  $K$  – coefficient of correction taking account of the transmission differences on the measuring line.

In the further investigations a nonlinear absorber has been additionally applied in the regenerative amplifier system [14], [15], the scheme of which is presented in Fig. 4. In order to assure the double passage of the pulse through the nonlinear absorber NA the latter was located at the distance  $l > (1/2)c\tau_{1/2}$  from the totally reflecting mirror M1. Next, the pulse formed in this way was amplified, similarly as before, in a sequence of Nd:glass amplifiers to the energy value  $E = 15$  J and the contrast ratio measurement was realized. The scheme of the whole high power laser system, in which the SMBS mirror is applied, is shown in Fig. 5.

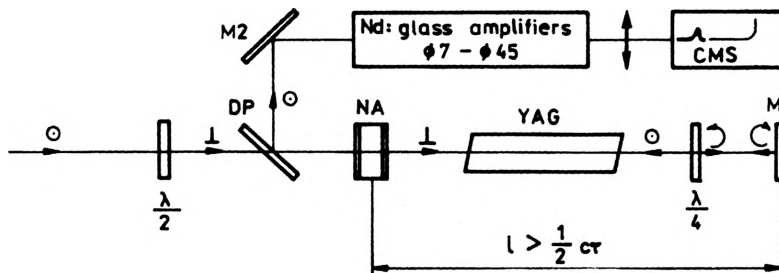

Fig. 4. Scheme of the regenerative amplifier. M1, M2 – dielectric mirrors,  $\lambda/2$ - $\lambda/4$  – phase plate, DP – dielectric polarizer, NA – nonlinear absorber, YAG – amplifier, CMS – contrast measuring system

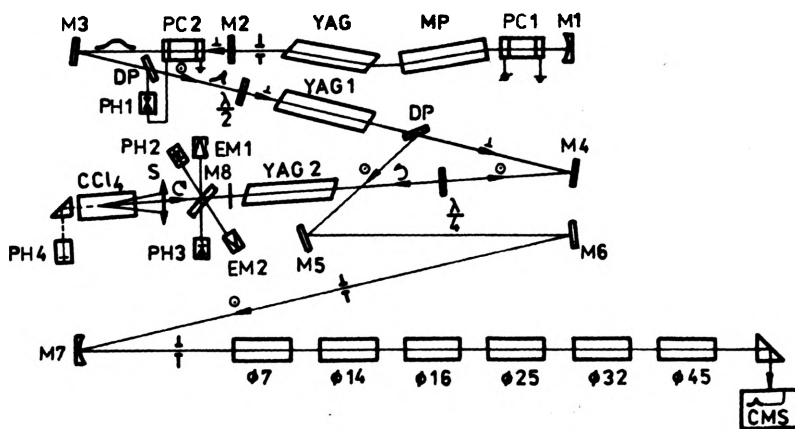

Fig. 5. Nd:glass high power laser system with SMBS mirror. M1–M8 – dielectric mirrors, PC1, PC2 – Pockels cells, DP – dielectric polarizer, MP – multiplate polarizer, YAG – laser head, YAG1, YAG2 – amplifiers, PH1–PH4 – photodiodes, EM1, EM2 – energy meters,  $\lambda/2$ ,  $\lambda/4$  – phase plates, L – lens,  $\phi 7$ - $\phi 45$  – Nd:glass amplifier, CMS – contrast measuring system

### 3. Results

In the system of SMBS mirror (Fig. 2) the carbon disulphide was used as an active medium. The stationary conditions of scattering ( $\tau_{1/2} \gg \tau_f$ , where:  $\tau_{1/2}$  – duration of the laser pulse (FWHM),  $\tau_f$  – life time of photons) [12], [13] for laser pulses of duration 5–20 ns being assumed a regular distribution of spatial power density of radiation reflected and diffraction divergence of the beam were recorded. For laser pulses of duration comparable with the phonon life time (for  $\text{CS}_2$ ,  $\tau_f = 2.2$  ns) a strongly nonhomogenous spatial power density distribution recorded in the beam reflected radiation was due to non-stationary scattering conditions. The time shapes of incident pulse and that reflected from the SMBS mirror are shown in Fig. 6a,b, respectively, for pulse duration  $\tau_{1/2} = 20$  ns and  $\tau_{1/2} = 5$  ns.

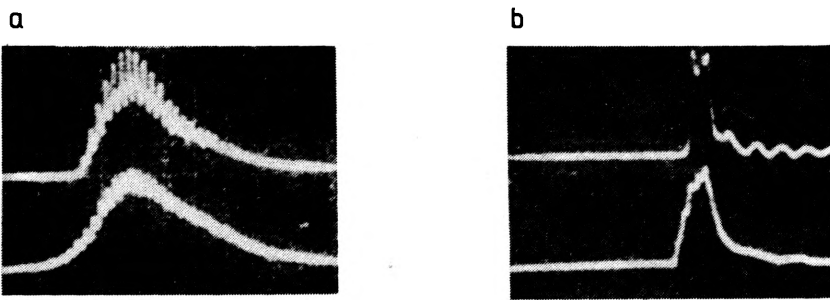

Fig. 6. Laser pulse oscillogram (input pulse at the bottom, pulse reflected from the SMBS mirror at the top). **a** – long pulse oscillogram (10 ns/div), **b** – short pulse oscillogram (5 ns/div)

As it follows from the oscillograms presented, the scattering in the system of SMBS mirror, due to its threshold character, brings about some sharpening of the foremost pulse front, and an increase of the modulation depth caused by the nonlinearity of the active medium. Further examinations of the SMBS mirror were carried out for the laser pulses of duration  $\tau_{1/2} = 3$  ns. In order to assure the stationary scattering conditions as the active medium the carbon tetrachloride was used, for which the phonon life time  $\tau_f = 86$  ps [13]. The oscillograms of the laser pulses obtained in the SMBS mirror system with the carbon tetrachloride are presented in Fig. 7. From the comparison of oscillograms **a** and **b** it follows that

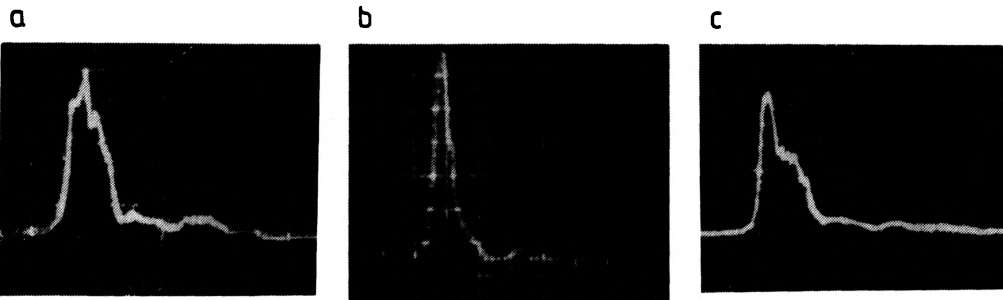

Fig. 7. Laser oscillograms obtained in the system with SMBS mirror. **a** – input pulse (1 V/div, 2 ns/div), **b** – reflected pulse (100 mV/div, 2 ns/div), **c** – passing pulse (1 V/div, 2 ns/div)

an abbreviation of the pulse duration to its halfvalue as well as some sharpening of the forehead pulse have been achieved. The shape of the passing pulse results from the mechanism of SMBS phenomenon [13].

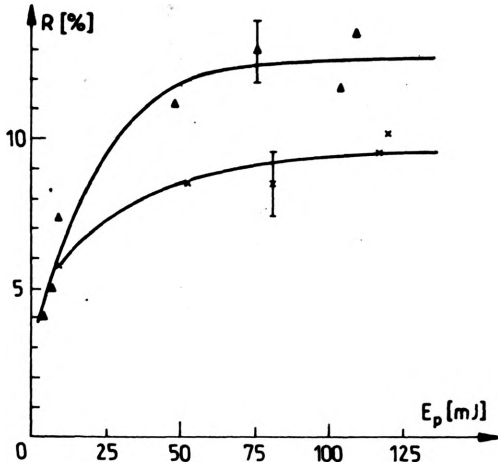

Fig. 8. Plot of the reflection coefficient  $R$  from the SMBS mirror as a function of input energy  $E_p$  for two lenses ( $\blacktriangle - f_1 = 10$  cm,  $\times - f_2 = 38$  cm)

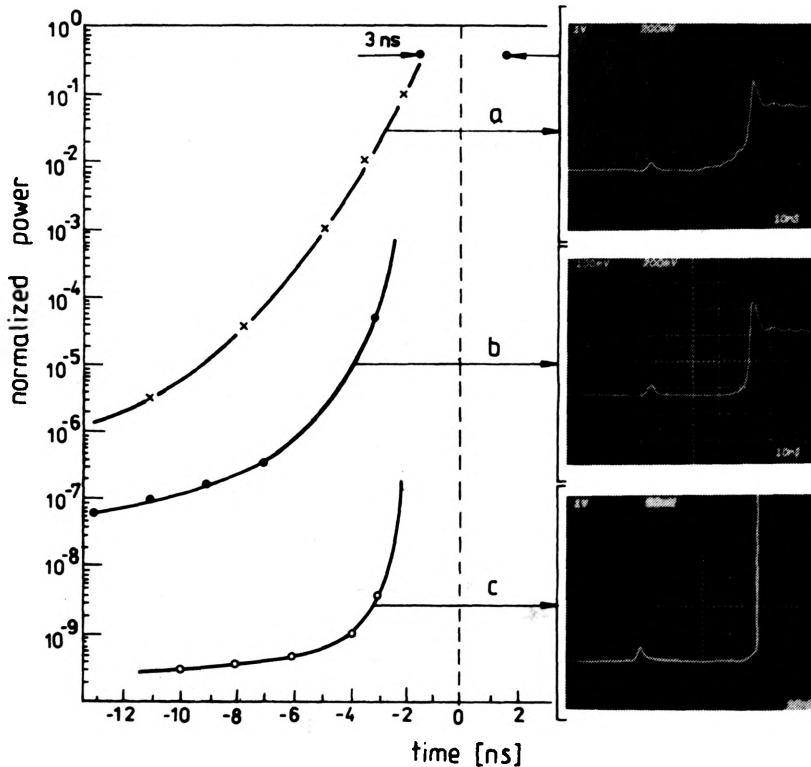

Fig. 9. Time shape of the laser prepulse and the corresponding oscillograms obtained by application: a – electrooptic system with Pockels cell and nonlinear absorber, b – SMBS mirror, c – SMBS mirror and a nonlinear absorber

The experimental results of the measurement of reflected energy as a function of incident energy  $E_p$  are shown in Fig. 8 for two values of lenses focal lengths  $f_1 = 10$  cm and  $f_2 = 38$  cm. As it follows from this figure a rapid increase of the reflection coefficient  $R$  is observed within the energy range up to 50 mJ, while for the further increase of input energy up to 150 mJ the reflection coefficient stabilized at the levels of 9 and 14% for the focal lengths  $f_2$  and  $f_1$ , respectively. For the pulse duration  $\tau_{1/2} = 3$  ns contrast ratio measured in the system without the SMBS mirrors (to enhance the contrast ratio an electrooptical system, shown in Fig. 1, and a nonlinear absorber were used) amounted to  $10^6$  \*. The oscillogram obtained for this case is shown in Fig. 9a. Next, an SMBS mirror has been applied and the measured contrast ratio increased to the value of  $10^7$ . The oscillogram for this measurement is shown in Fig. 9b.

In order to further increase the contrast ratio a nonlinear absorber was applied to the system presented in Fig. 4, and a contrast ratio of order of  $10^9$  was recorded. The corresponding oscillogram is shown in Fig. 9c. The time shape of the laser prepulse for the three cases discussed above is shown in Fig. 9.

#### 4. Conclusions

It has been shown experimentally that SMBS is a very effective method for increasing the laser pulse contrast ratio and combined with a nonlinear absorber in the two-pass regenerative amplifier system it assures both the contrast ratio of  $10^9$  at the output of the laser system and the shortening of the pulse duration. It has been observed that this method allows us to obtain the diffraction-limited divergence of the laser beam and a homogeneous transversal distribution of the power density, provided that the stationary scattering conditions are preserved. An application of the SMBS mirror allows us to eliminate the up-to-now enhancing contrast system which was composed of Pockels cell and four dielectric polarizers (Fig. 1).

In our experiment a phase conjugation of the laser pulse was also observed [14], however, this phenomenon was not analysed since it was not the subject of the study.

*Acknowledgements* – the authors wish to thank J. Kostecki, MSc., for his help in measurement of contrast ratio.

#### References

- [1] PENZKOFER A., HÄRTINGER F., WIEDMAN J., *Appl. Phys.* **B26** (1981), 239.
- [2] SPECK D. R., BLISS E. S., GLAZE J. A., HERRIS J. W., HOLLOWAY F. W., HUNT J. T., JOHNSON B. C., KUIZENGA D. J., OZARSKI R. G., PATTON H. G., RUPERT P. R., SUSKI G. J., SWIFT C. D., THOMPSON C. E., *IEEE J. Quant. Electron.* **QE-17** (1981), 1599.

---

\* The values of contrast ratio given in the paper correspond to the distance of 10 ns from the pulse peak.

- [3] GULEVICH V. M., ILYUKHIN A. A., MASLYANKIN V. A., SHELOBOLIN A. V., *Kvantovaya Elektronika* **9** (1982), 537 (in Russian).
- [4] KORMER S. B., KOCHEMASOV G. G., KULIKOV S. M., NIKOLAEV V. D., SUKHAREV S. A., *Zh. Eksp. Teor. Fiz.* **82** (1982), 1079 (in Russian).
- [5] KORMER S. B., KOCHEMASOV G. G., KULIKOV S. M., NIKOLAEV V. D., SUKHAREV S. A., *Zh. Tech. Fiz.* **50** (1980), 1319 (in Russian).
- [6] EROSHENKO V. A., KIRYANOV Yu. F., KORMER S. B., KOCHEMASOV G. G., NIKOLAEV V. D., *Kvantovaya Elektronika* **7** (1980), 2536 (in Russian).
- [7] ILYUKHIN A. A., PEREGUBOV G. V., PLOTKIN M. E., RAGOZIN E. N., CHIRKOV V. A., *Papers in Zh. Eksp. Teor. Fiz.* **29** (1979), 364 (in Russian).
- [8] DOLGOPOLOV Yu. V., KOMAREVSKII V. A., KORMER S. B., KOCHEMASOV G. G., KULIKOV S. M., MURUGOV V. M., NIKOLAEV V. D., SUKHAREV S. A., *Zh. Eksp. Teor. Fiz.* **76** (1979), 908 (in Russian).
- [9] RAGOZIN E. N., PLOTKIN M. E., *Kvantovaya Elektronika* **7** (1980), 1583 (in Russian).
- [10] ZELDOVICH B. Ya., POPOVICHEV V. I., RAGULSKII V. V., FAIZULLOV F. S., *Papers in Zh. Eksp. Teor. Fiz.* **15** (1972), 160 (in Russian).
- [11] WANG V., GIULIANO S., *Opt. Lett.* **2** (1979), 4.
- [12] TANG C. L., *J. Appl. Phys.* **37** (1966), 2945.
- [13] STARUNOV V. S., FABELINSKII P. L., *Usp. Fiz. Nauk* **98** (1969), 441 (in Russian).
- [14] ZELDOVICH B. Ya., PILIPETSKII N. F., SHKUNOV V. V., *Usp. Fiz. Nauk* **138** (1982), 249 (in Russian).

*Received October 4, 1985*

*in revised form December 17, 1985*

### **Исследование влияния вынужденного рассеяния Мандельштама–Бриллюэна на временные параметры импульса лазера Nd:YAG**

В настоящей работе представлен метод формирования лазерного импульса, в котором использовано вынужденное рассеяние Мандельштама–Бриллюэна. Использование этого метода в лазерной установке большой мощности на неодимовом стекле позволило получить контраст импульса  $10^9$ .