

Harmonic analysis of time-dependent polarizing systems for Jones calculus

W. URBAŃCZYK

Institute of Physics, Technical University of Wrocław, Wybrzeże Wyspiańskiego 27, 50-370 Wrocław, Poland.

The modulation of polarization state is now widely applied in optical measuring systems. Every measuring system consists of a number of individual polarizing elements which can be represented in Mueller or Jones notation, respectively. In the present paper, the harmonic analysis, undertaken earlier for the Mueller notation, will be extended also for the Jones representation. The harmonic equivalents of the Jones matrix, the coherency matrix and the Jones vector will be defined and their basic properties described. The harmonic matrices of the most commonly used modulators will be determined. Furthermore, the analytical formulas for the amplitudes and the phase shifts of particular harmonic components of the total intensity emergent from any measuring system with a single modulator will be derived. The usability of the harmonic representation to the systematic error analysis will be demonstrated on the example of birefringence measuring system with the linear phase modulation. The differential Jones matrices enabling the first order error analysis will also be determined.

1. Introduction

The modulation of polarization state is applied to the variety of measuring systems as ellipsometers, polarimeters, birefringence measuring systems and to some types of polarizaton interferometers. In principle, every measuring system consists of a single periodical modulator and a sequence of polarizing elements properly made and adjusted. The output intensity is time-dependent and usually the phase shifts or the amplitudes of harmonic components of the output intensity are measured. We should realize that every individual polarizing element being a function of five parameters (i.e., the transmission of the faster k_f and slower k_s eigenwaves, the azimuth α and the ellipticity ϑ of the faster eigenwaves, the phase retardation γ between faster and slower eigenwaves) is manufactured and aligned with certain error. So, a difficult question arises, how errors of particular elements of measuring system influence the final measurement results. A lot of efforts have been made [1]–[9] to determine the systematic measurement errors for variety of measuring systems with different modulation and detection techniques. In all those papers, the analysis of errors was carried out in the time-domain. At first, the analytical formula for the total intensity of beam emergent from measuring system is determined, and next, this formula is developed into a series of harmonic components. As a result, the influence of the errors of individual elements of the system on the measurement accuracy can be analysed.

In the recent paper [10], the Fourier formalism has been proposed (for Mueller notation, only), enabling one to determine, how particular harmonic components of intensity are propagated through the measuring systems. Furthermore, it was possible to express the phase shifts and the amplitudes of the harmonic components of the output intensity as the analytical function of the Mueller matrices representing individual elements of the system. It was also demonstrated that these formulas are very useful for the systematic errors analysis. So, the final conclusion of the recent paper was that the systematic error analysis should be carried out with the help of the proposed Fourier formalism rather than directly in the time-domain.

In the present paper, the harmonic representation will be extended also on the Jones notation. The usability of the proposed Fourier formalism to the systematic error analysis will be demonstrated on the example of birefringence measuring system with the linear phase modulation.

2. Fundamental definitions in a frequency-domain

Let us initially assume that a polarizing system consists of only one time-dependent element (Fig. 1). The polarization state of the input beam can be represented by

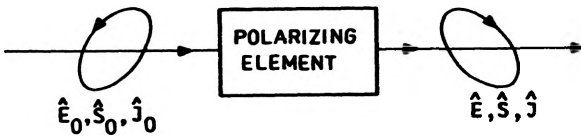

Fig. 1. Transformation of the polarization state by the polarizing element

Jones vector \hat{E}_0 , Stokes vector \hat{S}_0 or coherency matrix \hat{J}_0 . The output polarization state can therefore be determined in one of the following three ways:

$$\begin{aligned}\hat{E}(t) &= \hat{T}(t)\hat{E}_0, \\ \hat{S}(t) &= \hat{M}(t)\hat{S}_0, \\ \hat{J}(t) &= \hat{T}(t)\hat{J}_0\hat{T}^\dagger(t)\end{aligned}\quad (1)$$

where $\hat{T}(t)$ and $\hat{M}(t)$ are Jones and Mueller matrices, respectively, and symbol \dagger denotes Hermitian adjoint of matrix. The final state of polarization which depends on time can be represented in the form of Fourier integrals:

$$\begin{aligned}\hat{E}(t) &= \int_{-\infty}^{\infty} \hat{e}(\omega)\exp(2\pi j\omega t)d\omega, \\ \hat{S}(t) &= \int_{-\infty}^{\infty} \hat{s}(\omega)\exp(2\pi j\omega t)d\omega, \\ \hat{J}(t) &= \int_{-\infty}^{\infty} \hat{j}(\omega)\exp(2\pi j\omega t)d\omega,\end{aligned}\quad (2)$$

where the integration refers to all the elements of matrix $\hat{j}(\omega)$ and vectors $\hat{e}(\omega)$, $\hat{s}(\omega)$. Harmonic components of the Jones and Stokes vectors as well as the coherency matrix are defined with the help of inverse Fourier integrals:

$$\begin{aligned}\hat{e}(\omega) &= \int_{-\infty}^{\infty} \hat{E}(t) \exp(-2\pi j\omega t) dt, \\ \hat{s}(\omega) &= \int_{-\infty}^{\infty} \hat{S}(t) \exp(-2\pi j\omega t) dt, \\ \hat{j}(\omega) &= \int_{-\infty}^{\infty} \hat{J}(t) \exp(-2\pi j\omega t) dt.\end{aligned}\tag{3}$$

Substituting to the above equations, the expressions for the final polarization state (Eqs. (1)), we obtain:

$$\begin{aligned}\hat{e}(\omega) &= \hat{i}(\omega) \hat{E}_0, \\ \hat{s}(\omega) &= \hat{m}(\omega) \hat{S}_0, \\ \hat{j}(\omega) &= \hat{i}(\omega) \hat{J}_0 \star \hat{i}(\omega),\end{aligned}\tag{4}$$

where $\hat{i}(\omega)$ and $\hat{m}(\omega)$ are harmonic components of Jones and Mueller matrices:

$$\begin{aligned}\hat{i}(\omega) &= \int_{-\infty}^{\infty} \hat{T}(t) \exp(-2\pi j\omega t) dt, \\ \hat{m}(\omega) &= \int_{-\infty}^{\infty} \hat{M}(t) \exp(-2\pi j\omega t) dt,\end{aligned}\tag{5}$$

and the symbol \star denotes correlation of two matrices, see Appendix. Equations (4) make it possible to determine harmonic components of Jones and Stokes vectors and coherency matrix of the output beam if the input polarization state and the harmonic components of the matrix that represents modulator are known.

3. Basic properties of harmonic components

In this Section, basic properties of the Fourier components of the Jones vector $\hat{e}(\omega)$, the coherency matrix $\hat{j}(\omega)$ as well as the Jones matrix $\hat{i}(\omega)$ will be discussed.

3.1. Cascade of polarizing elements

If a polarizing system consists of two or more time-dependent elements, the output polarization state can be determined in one of the following ways:

$$\begin{aligned}\hat{E}(t) &= \hat{T}_B(t) \hat{T}_A(t) \hat{E}_0, \\ \hat{J}(t) &= \hat{T}_B(t) \hat{T}_A(t) \hat{J}_0 \hat{T}_A^\dagger(t) \hat{T}_B^\dagger(t).\end{aligned}\tag{6}$$

Applying the inverse Fourier transform to the above equations we can readily give the adequate relations for harmonic components:

$$\begin{aligned}\hat{e}(\omega) &= \hat{t}_B(\omega) \times \hat{t}_A(\omega) \hat{E}_0, \\ \hat{j}(\omega) &= \hat{t}_B(\omega) \times \hat{t}_A(\omega) \hat{J}_0 \star \hat{t}_A(\omega) \times \hat{t}_B(\omega).\end{aligned}\quad (7)$$

The structures of equations in the time- and frequency-domain are identical. The only difference is that in the frequency-domain the multiplication of matrices is substituted by their convolution (\times) or cross-correlation (\star), see Appendix. In the case where one of the elements (e.g., element A) is independent of time, Eqs. (7) take the form:

$$\begin{aligned}\hat{e}(\omega) &= \hat{t}_B(\omega) \hat{T}_A \hat{E}_0, \\ \hat{j}(\omega) &= \hat{t}_B(\omega) \hat{T}_A \hat{J}_0 \star \hat{T}_A \hat{t}_B(\omega).\end{aligned}\quad (8)$$

3.2. Transformation of the harmonic components under the effect of coordinate rotation or base vectors transformation

A rotation of coordinate axes with respect to which the polarization state or polarizing element is represented gives rise to the transformation of vector $\hat{E}(t)$ and matrices $\hat{J}(t)$, $\hat{T}(t)$. Let the index α denote vectors and matrices in a new coordinate system obtained from an old one by a rotation through an angle α . Adequate transformations of vectors and matrices in time-domain are given by:

$$\begin{aligned}\hat{E}_\alpha(t) &= \hat{R}(\alpha) \hat{E}(t), \\ \hat{J}_\alpha(t) &= \hat{R}(\alpha) \hat{J}(t) \hat{R}(-\alpha), \\ \hat{T}_\alpha(t) &= \hat{R}(\alpha) \hat{T}(t) \hat{R}(-\alpha)\end{aligned}\quad (9)$$

where $\hat{R}(\alpha)$ represents the rotation matrix

$$\hat{R}(\alpha) = \begin{bmatrix} \cos \alpha, & \sin \alpha \\ -\sin \alpha, & \cos \alpha \end{bmatrix}.\quad (10)$$

Since rotation matrices are independent of time, then identical equations describe also transformations of harmonic components:

$$\begin{aligned}\hat{e}_\alpha(\omega) &= \hat{R}(\alpha) \hat{e}(\omega), \\ \hat{j}_\alpha(\omega) &= \hat{R}(\alpha) \hat{j}(\omega) \hat{R}(-\alpha), \\ \hat{t}_\alpha(\omega) &= \hat{R}(\alpha) \hat{t}(\omega) \hat{R}(-\alpha).\end{aligned}\quad (11)$$

Rotation of a coordinate system is one of the simplest examples of transformations of base vectors according to which the matrices $\hat{J}(t)$, $\hat{T}(t)$, and vector $\hat{E}(t)$ are constructed. In certain problems, due to considerable simplification of the description, it is more suitable to replace the orthogonal base vectors representing two linear polarization states by orthonormal vectors corresponding to left- and right-circular polarization. This gives rise to the transformation (in time- and frequency-domain) of Jones vector, coherency and Jones matrices. The transformations are identical as in the case of coordinate system rotation, Eqs. (9) and (11). It

is required only to substitute the rotation matrix $\hat{R}(\alpha)$ for the matrix representing simple and inverse transformations of base vectors.

3.3. Interrelations between different representations of polarization state

It is known that the components of the Stokes vector are a simple linear combination of the elements of the coherency matrix [11]

$$\begin{aligned} [\hat{S}(t)]_1 &= [\hat{J}(t)]_{11} + [\hat{J}(t)]_{22}, \\ [\hat{S}(t)]_2 &= [\hat{J}(t)]_{11} - [\hat{J}(t)]_{22}, \\ [\hat{S}(t)]_3 &= [\hat{J}(t)]_{12} + [\hat{J}(t)]_{21}, \\ [\hat{S}(t)]_4 &= -j\{[\hat{J}(t)]_{12} - [\hat{J}(t)]_{21}\} \end{aligned} \quad (12)$$

where $[\hat{J}(t)]_{ik}$ indicates i, k element of the coherency matrix. Also the Mueller and Jones matrices are interrelated [11]

$$\hat{M}(t) = \hat{Q} \hat{T}(t) \circ \hat{T}^\dagger(t) \hat{Q}^{-1} \quad (13)$$

where \circ denotes the Kronecker product of two matrices, with \hat{Q} being the transformation matrix given by

$$\hat{Q} = \begin{bmatrix} 1, & 0, & 0, & 1, \\ 1, & 0, & 0, & -1, \\ 0, & 1, & 1, & 0, \\ 0, & -j, & j, & 0, \end{bmatrix}. \quad (14)$$

It can readily be shown that similar relations are also fulfilled for the harmonic components:

$$\begin{aligned} [\hat{s}(\omega)]_1 &= [\hat{j}(\omega)]_{11} + [\hat{j}(\omega)]_{22}, \\ [\hat{s}(\omega)]_2 &= [\hat{j}(\omega)]_{11} - [\hat{j}(\omega)]_{22}, \\ [\hat{s}(\omega)]_3 &= [\hat{j}(\omega)]_{12} + [\hat{j}(\omega)]_{21}, \\ [\hat{s}(\omega)]_4 &= -j\{[\hat{j}(\omega)]_{12} - [\hat{j}(\omega)]_{21}\}, \end{aligned} \quad (15)$$

and

$$\hat{m}(\omega) = \hat{Q} \hat{t}(\omega) \otimes \hat{t}(\omega) \hat{Q}^{-1} \quad (16)$$

where \otimes denotes the autocorrelation of two matrices in the Kronecker sense, see the Appendix.

3.4. Total beam intensity

The total intensity of polarized light beam is equal to a trace of a matrix [11]

$$\begin{aligned} \hat{I}(t) &= \text{tr}[\hat{E}(t) \hat{E}^\dagger(t)], \\ \hat{I}(t) &= \text{tr}[\hat{J}(t)]. \end{aligned} \quad (17)$$

Since the total intensity of modulated beam depends on time, it can be represented in the form of an integral of harmonic components

$$I(t) = \int_{-\infty}^{\infty} i(\omega) \exp(2\pi j\omega t) d\omega, \quad (18)$$

with the following relations between harmonic components of intensity and harmonic components of Jones vector and coherence matrix being fulfilled

$$\begin{aligned} i(\omega) &= \text{tr}[\hat{e}(\omega) \star \hat{e}(\omega)], \\ i(\omega) &= \text{tr}[\hat{j}(\omega)]. \end{aligned} \quad (19)$$

The above equations make it possible to determine, for any polarizing system, the amplitudes and phase shifts of each harmonic component of the total intensity of an output beam. However, the output harmonic components of the Jones vector and the coherency matrix should be known earlier. From the analysis presented in this section it appears that their determination is quite simple since the harmonic components $\hat{e}(\omega)$, $\hat{j}(\omega)$ are transmitted through the polarizing system in a very similar manner to their time-dependent equivalents $\hat{E}(t)$ and $\hat{J}(t)$.

3.5. Polarizing systems with periodical modulators

So far, we have not been assuming that the properties of polarizing systems vary in time periodically. Most measuring systems consist of a single modulator and a cascade of polarizing elements independent of time (Fig. 2). The modulators usually

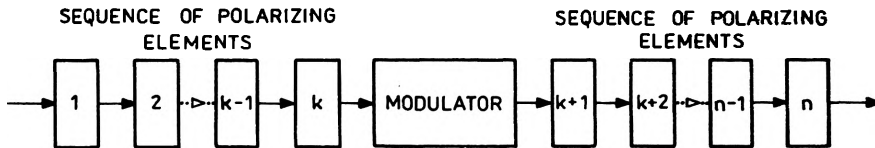

Fig. 2. Typical configuration of the measuring system

applied are periodical. This means that their harmonic spectrum is discrete, and their harmonic matrices can be represented as a sum

$$\hat{t}(\omega) = \sum_{k=-\infty}^{\infty} \hat{t}_k \delta(\omega - k\omega_0), \quad (20)$$

where $\delta(\omega - k\omega_0)$ indicates the Dirac delta, and ω_0 is the fundamental frequency of modulation. Harmonic components of the output polarization state can be represented in one of the following ways:

$$\begin{aligned} \hat{e}(\omega) &= \hat{T}_B \hat{t}(\omega) \hat{T}_A \hat{E}_0, \\ \hat{j}(\omega) &= \hat{T}_B \hat{t}(\omega) \hat{T}_A J_0 \star \hat{T}_A(\omega) \hat{T}_B \end{aligned} \quad (21)$$

where \hat{E}_0 and \hat{J}_0 are the input polarization states and the matrices \hat{T}_A and \hat{T}_B represent the combined effect of n polarizing elements placed in front of and behind the modulator

$$\hat{T}_A = \hat{T}_k \hat{T}_{k-1}, \dots, \hat{T}_2 \hat{T}_1, \quad \hat{T}_B = \hat{T}_n \hat{T}_{n-1}, \dots, \hat{T}_{k-2} \hat{T}_{k+1}, \quad (22)$$

respectively.

From the point of view of practical applications, it is more convenient to represent the periodic signals in the form of Fourier series. For the total output intensity, following equation can be written:

$$I(t) = \sum_{k=0}^{\infty} I_k \cos(k\omega_0 t - \varphi_k) \quad (23)$$

where I_k and φ_k represent the amplitudes and phase shifts of the harmonic components of frequency $k\omega_0$, respectively. After the elementary transformations, we can show that

$$I_k = 2|i(k\omega_0)| = 2|i(-k\omega_0)|, \quad (24a)$$

and

$$\varphi_k = \arctan \frac{\text{Im}\{i(k\omega_0)\}}{\text{Re}\{i(k\omega_0)\}}. \quad (24b)$$

Combining the formulae (24), (21), (20) and (19), the amplitudes and phase shifts of harmonic components of output intensity can be expressed as:

$$I_k = 2 \left| \sum_{l=-\infty}^{\infty} \text{tr}[\hat{T} \hat{t}_l \hat{J}_0 \hat{t}_{l-k}^{\dagger} \hat{T}^{\dagger}] \right|, \quad (25a)$$

$$\varphi_k = \arctan \frac{\sum_{l=-\infty}^{\infty} \text{Im}\{\text{tr} \hat{T} \hat{t}_l \hat{J}_0 \hat{t}_{l-k}^{\dagger} \hat{T}^{\dagger}\}}{\sum_{l=-\infty}^{\infty} \text{Re}\{\text{tr} \hat{T} \hat{t}_l \hat{J}_0 \hat{t}_{l-k}^{\dagger} \hat{T}^{\dagger}\}} \quad (25b)$$

where $\text{Im}\{\dots\}$ and $\text{Re}\{\dots\}$ is the imaginary and real part, respectively.

If the input polarization state is represented by Jones vector \hat{E}_0 , the coherency matrix in the above equations should be replaced by the product $\{\hat{E}_0 \hat{E}_0^{\dagger}\}$.

3.6. Harmonic matrices of the linear and the sinusoidal modulators

In the measuring practice, it is either the azimuth or the ellipticity of polarization state that is modulated. In general, two types of modulators, can be distinguished – sinusoidal and linear. In this subsection, as an example, the harmonic matrices of the sinusoidal and linear modulators of azimuth will be determined.

Applying the general form of the Jones matrix (see Appendix B), we will find the time-dependent representation of sinusoidal modulator of azimuth

$$\hat{T}(t) = \begin{bmatrix} \cos(\alpha_0 + \alpha_1 \sin \omega_0 t), & \sin(\alpha_0 + \alpha_1 \sin \omega_0 t) \\ -\sin(\alpha_0 + \alpha_1 \sin \omega_0 t), & \cos(\alpha_0 + \alpha_1 \sin \omega_0 t) \end{bmatrix} \quad (26)$$

where α_0 , α_1 , ω_0 indicate the initial azimuth, the depth of modulation and the fundamental frequency of modulation, respectively. The harmonic matrices \hat{t}_k can be determined if the Fourier spectrum of the functions $\cos(\alpha_0 + \alpha_1 \sin \omega_0 t)$ and $\sin(\alpha_0 + \alpha_1 \sin \omega_0 t)$ are known. Carrying out necessary calculations, we obtain

$$\hat{t}_0 = J_0(\alpha_1) \begin{bmatrix} \cos \alpha_0, & \sin \alpha_0 \\ -\sin \alpha_0, & \cos \alpha_0 \end{bmatrix} \quad (27a)$$

and, for $k \neq 0$, we have:

$$\hat{t}_{2k-1} = J_{2k-1}(\alpha_1) \begin{bmatrix} j \sin \alpha_0, & -j \cos \alpha_0 \\ j \cos \alpha_0, & j \sin \alpha_0 \end{bmatrix}, \quad (27b)$$

$$\hat{t}_{2k} = J_{2k}(\alpha_1) \begin{bmatrix} \cos \alpha_0, & \sin \alpha_0 \\ -\sin \alpha_0, & \cos \alpha_0 \end{bmatrix}$$

where $J_k(\alpha_1)$ is the k -th order of Bessel function. For the linear modulator of azimuth, the time-dependent Jones matrix takes the form

$$\hat{T}(t) = \begin{bmatrix} \cos(\alpha_0 + \omega_0 t), & \sin(\alpha_0 + \omega_0 t) \\ -\sin(\alpha_0 + \omega_0 t), & \cos(\alpha_0 + \omega_0 t) \end{bmatrix} \quad (28)$$

and its harmonic components equal

$$\begin{aligned} \hat{t}_0 &= \begin{bmatrix} 0, & 0 \\ 0, & 0 \end{bmatrix}, \\ \hat{t}_1 &= \frac{1}{2} \begin{bmatrix} \cos \alpha_0 + j \sin \alpha_0, & \sin \alpha_0 - j \cos \alpha_0 \\ j \cos \alpha_0 - \sin \alpha_0, & \cos \alpha_0 + j \sin \alpha_0 \end{bmatrix}, \\ \hat{t}_{-1} &= \hat{t}_1^*. \end{aligned} \quad (29)$$

The harmonic matrices representing higher frequencies are equal to zero for linear modulators.

In this subsection, as an example, only the harmonic matrices of the azimuth modulators were determined. However, by analogy, one could readily determine the harmonic matrices in the case of ellipticity modulation.

4. Exemplary analysis of systematic measurement error

The usability of the proposed Fourier representation to the systematic error

analysis will be demonstrated on the example of birefringence measuring system. The sequence of polarizing elements of the system and their azimuths are shown in Fig. 3.

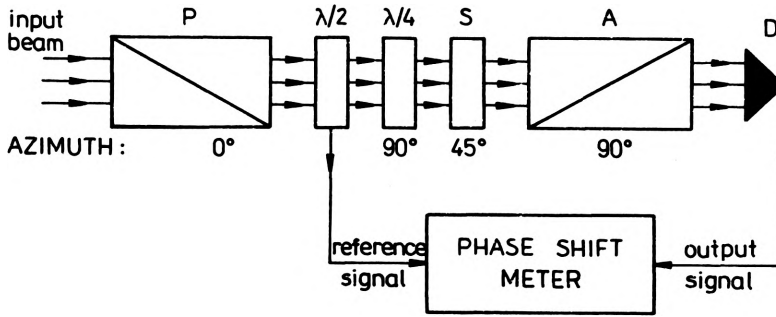

Fig. 3. Scheme of the birefringence measuring system with the linear modulation. P – polarizer, $\lambda/2$ – rotating halfwave plate, $\lambda/4$ – quarterwave plate, S – birefringent sample, A – analyser, D – intensity detector

It is a classical measuring system with the linear phase modulation [12]–[14], and such errors analysis has not been undertaken earlier. The linear modulator is composed of the $\lambda/2$ plate rotating with angular velocity ω_0 and the $\lambda/4$ plate with the azimuth 90° . Due to the modulation, the output intensity is time-dependent

$$I(t) = I_0 [1 + \cos(4\omega_0 t + \varphi_s)] \tag{30}$$

where φ_s is the phase shift introduced by the birefringent sample. Usually, the rotating $\lambda/2$ plate generates the reference signal of the frequency $4\omega_0$ and the zero initial phase shift. Thus, the phase shift φ_s introduced by the birefringent sample is directly equal to the phase retardation between reference and output signals. In accordance with Eq. (25b) φ_s can be expressed as

$$\varphi_s = \arctan \frac{\text{Im} \{ \text{tr} [\hat{T}_A \hat{T}_S \hat{T}_{\lambda/4} \hat{t}_2 \hat{T}_P \hat{J}_0 \hat{T}_P \hat{t}_{-2} \hat{T}_{\lambda/4} \hat{T}_S \hat{T}_A] \}}{\text{Re} \{ \text{tr} [\hat{T}_A \hat{T}_S \hat{T}_{\lambda/4} \hat{t}_2 \hat{T}_P \hat{J}_0 \hat{T}_P \hat{t}_{-2} \hat{T}_{\lambda/4} \hat{T}_S \hat{T}_A] \}} \tag{31}$$

The Jones matrices of ideal elements of the system are given by (see Appendix B):

$$\begin{aligned} \hat{T}_P &= \begin{bmatrix} 1, & 0 \\ 0, & 0 \end{bmatrix}, & \hat{T}_A &= \begin{bmatrix} 0, & 0 \\ 0, & 1 \end{bmatrix}, \\ \hat{T}_{\lambda/2}(t) &= \begin{bmatrix} \cos(2\omega_0 t), & \sin(2\omega_0 t) \\ -\sin(2\omega_0 t), & \cos(2\omega_0 t) \end{bmatrix}, & \hat{T}_{\lambda/4} &= \begin{bmatrix} 1, & 0 \\ 0, & j \end{bmatrix}, \\ \hat{T}_S &= \begin{bmatrix} \cos \varphi_s / 2, & j \sin \varphi_s / 2 \\ j \sin \varphi_s / 2, & \cos \varphi_s / 2 \end{bmatrix}, \end{aligned} \tag{32}$$

and the harmonic matrices of the rotating $\lambda/2$ plate equal

$$\hat{t}_0 = \begin{bmatrix} 0, & 0 \\ 0, & 0 \end{bmatrix}, \quad \hat{t}_2 = \begin{bmatrix} 1, & -j \\ j, & 1 \end{bmatrix}, \quad \hat{t}_{-2} = \begin{bmatrix} 1, & j \\ -j, & 1 \end{bmatrix}. \quad (33)$$

The formula (31) was derived under the assumption that all elements of measuring system are perfectly made and aligned. However, real elements are made and aligned with errors which means that the measured phase shift φ_M will not have to be equal to the phase shift introduced by the birefringent sample φ_S . The systematic measurement error $\Delta\varphi_{er} = \varphi_M - \varphi_S$ caused by the imperfections of any element of the system can be determined from Eq. (31). For example, the error caused by the polarizer is given by

$$\begin{aligned} \Delta\varphi_{er} = & \arctan \frac{\text{Im}\{\text{tr}[\hat{T}_A \hat{T}_S \hat{T}_{\lambda/4} \hat{t}_2 \hat{T}_P^{\text{er}} \hat{J}_0 \hat{T}_P^{\text{er} \dagger} \hat{t}_{-2} \hat{T}_{\lambda/4}^{\dagger} \hat{T}_S^{\dagger} \hat{T}_A^{\dagger}]\}}{\text{Re}\{\text{tr}[\hat{T}_A \hat{T}_S \hat{T}_{\lambda/4} \hat{t}_2 \hat{T}_P^{\text{er}} \hat{J}_0 \hat{T}_P^{\text{er} \dagger} \hat{t}_{-2} \hat{T}_{\lambda/4}^{\dagger} \hat{T}_S^{\dagger} \hat{T}_A^{\dagger}]\}} \\ & - \arctan \frac{\text{Im}\{\text{tr}[\hat{T}_A \hat{T}_S \hat{T}_{\lambda/4} \hat{t}_2 \hat{T}_P \hat{J}_0 \hat{T}_P^{\dagger} \hat{t}_{-2} \hat{T}_{\lambda/4}^{\dagger} \hat{T}_S^{\dagger} \hat{T}_A^{\dagger}]\}}{\text{Re}\{\text{tr}[\hat{T}_A \hat{T}_S \hat{T}_{\lambda/4} \hat{t}_2 \hat{T}_P \hat{J}_0 \hat{T}_P^{\dagger} \hat{t}_{-2} \hat{T}_{\lambda/4}^{\dagger} \hat{T}_S^{\dagger} \hat{T}_A^{\dagger}]\}} \end{aligned} \quad (34)$$

where \hat{T}_P^{er} is the Jones matrix of imperfect polarizer. It should be underlined that the above formula is valid for any polarizer (the same refers to the other elements) imperfections, i.e., there were not made any restrictions referring to the kind and value of imperfections.

If the errors of individual elements of the system are small, we can apply the so-called first order error analysis. It means that the first order coupling coefficients indicating how particular errors of elements influence the measurement result can be found. Differentiating Eq. (31), we get

$$\begin{aligned} \frac{\partial\varphi_S}{\partial x} = & 16 \{ \text{Re}\{\text{tr}[\hat{T}_A \hat{T}_S \hat{T}_{\lambda/4} \hat{t}_2 \hat{T}_P \hat{J}_0 \hat{T}_P^{\dagger} \hat{t}_{-2} \hat{T}_{\lambda/4}^{\dagger} \hat{T}_S^{\dagger} \hat{T}_A^{\dagger}]\} \\ & \times \text{Im}\left\{ \text{tr}\left[\frac{\partial\hat{T}_A}{\partial x} \hat{T}_S \hat{T}_{\lambda/4} \hat{t}_2 \hat{T}_P \hat{J}_0 \hat{T}_P^{\dagger} \hat{t}_{-2} \hat{T}_{\lambda/4}^{\dagger} \hat{T}_S^{\dagger} \hat{T}_A^{\dagger} \right. \right. \\ & \left. \left. + \hat{T}_A \hat{T}_S \hat{T}_{\lambda/4} \hat{t}_2 \hat{T}_P \hat{J}_0 \hat{T}_P^{\dagger} \hat{t}_{-2} \hat{T}_{\lambda/4}^{\dagger} \hat{T}_S^{\dagger} \frac{\partial\hat{T}_A^{\dagger}}{\partial x} \right] \right\} \\ & - \text{Im}\{\text{tr}[\hat{T}_A \hat{T}_S \hat{T}_{\lambda/4} \hat{t}_2 \hat{T}_P \hat{J}_0 \hat{T}_P^{\dagger} \hat{t}_{-2} \hat{T}_{\lambda/4}^{\dagger} \hat{T}_S^{\dagger} \hat{T}_A^{\dagger} \\ & \times \text{Re}\left\{ \text{tr}\left[\frac{\partial\hat{T}_A}{\partial x} \hat{T}_S \hat{T}_{\lambda/4} \hat{t}_2 \hat{T}_P \hat{J}_0 \hat{T}_P^{\dagger} \hat{t}_{-2} \hat{T}_{\lambda/4}^{\dagger} \hat{T}_S^{\dagger} \hat{T}_A^{\dagger} \right. \right. \\ & \left. \left. + \hat{T}_A \hat{T}_S \hat{T}_{\lambda/4} \hat{t}_2 \hat{T}_P \hat{J}_0 \hat{T}_P^{\dagger} \hat{t}_{-2} \hat{T}_{\lambda/4}^{\dagger} \hat{T}_S^{\dagger} \frac{\partial\hat{T}_A^{\dagger}}{\partial x} \right] \right\} \end{aligned} \quad (35)$$

where ∂x can formally indicate the extinction error (∂k), the residual ellipticity ($\partial\theta$), the azimuth error ($\partial\alpha$) or the retardation error ($\partial\gamma$), and $\partial\hat{T}_P/\partial x$ is the differential Jones matrix for the polarizer (see Appendix B).

The expressions (34) and (35) are convenient for both numerical and analytical error analysis. As an example, the first order coupling coefficients were found for the polarizer, the birefringent sample and the analyser, respectively. After the necessary calculations we get for the polarizer:

$$\frac{\partial \varphi_s}{\partial k} = 0, \quad \frac{\partial \varphi_s}{\partial \alpha} = 2, \quad \frac{\partial \varphi_s}{\partial \vartheta} = 0, \quad (36a)$$

for the birefringent sample:

$$\frac{\partial \varphi_s}{\partial k} = 0, \quad \frac{\partial \varphi_s}{\partial \alpha} = 0, \quad \frac{\partial \varphi_s}{\partial \vartheta} = 0, \quad (36b)$$

and for the analyser:

$$\frac{\partial \varphi_s}{\partial k} = 0, \quad \frac{\partial \varphi_s}{\partial \alpha} = 0, \quad \frac{\partial \varphi_s}{\partial \alpha} = -2, \quad (36c)$$

respectively.

In accordance with Equation (34), the exact error analysis was also carried out. The ellipticity, azimuth and extinction errors in all three cases were assumed to be $\Delta \vartheta = \pm 10^\circ$, $\Delta \alpha = \pm 10^\circ$, $\Delta k = 0-0.1$, respectively. The results of the analysis are as follows:

i) The polarizer extinction error and the polarizer residual ellipticity have no influence on the measurement accuracy. The polarizer misalignment gives the measurement error exactly equal to $\Delta \varphi_{er} = 2\Delta \alpha$ and $\Delta \varphi_{er}$ is not dependent on the measured phase shift φ_s .

ii) The measurement errors introduced by the misalignment and the residual ellipticity of the birefringent sample are shown in Fig. 4. The residual dichroism of the sample has no influence on the measurement accuracy.

iii) The analyser extinction error and the analyser misalignment have no influence on the measurement accuracy. The analyser residual ellipticity introduces the measurement error equal to $\Delta \varphi_{er} = -2$ and $\Delta \varphi_{er}$ is not dependent on the measurement phase shift φ_s .

It is now evident that critical for the measurement accuracy are the residual ellipticity of the analyser and the azimuth error (misalignment) of the polarizer. In the first order approximation, the misalignment and the residual ellipticity of the sample have no influence on the measurement accuracy. However, the exact analysis shows (Fig. 4) that these parameters can also affect the measurement results. It is interesting that the extinction errors of the polarizer and the analyser, the residual dichroism of the sample, residual ellipticity of the analyser and the misalignment of polarizer do not introduce any measurement errors, except for the increase of the S/N ratio.

5. Conclusions

The Fourier representation of time-dependent polarizing systems, proposed recently

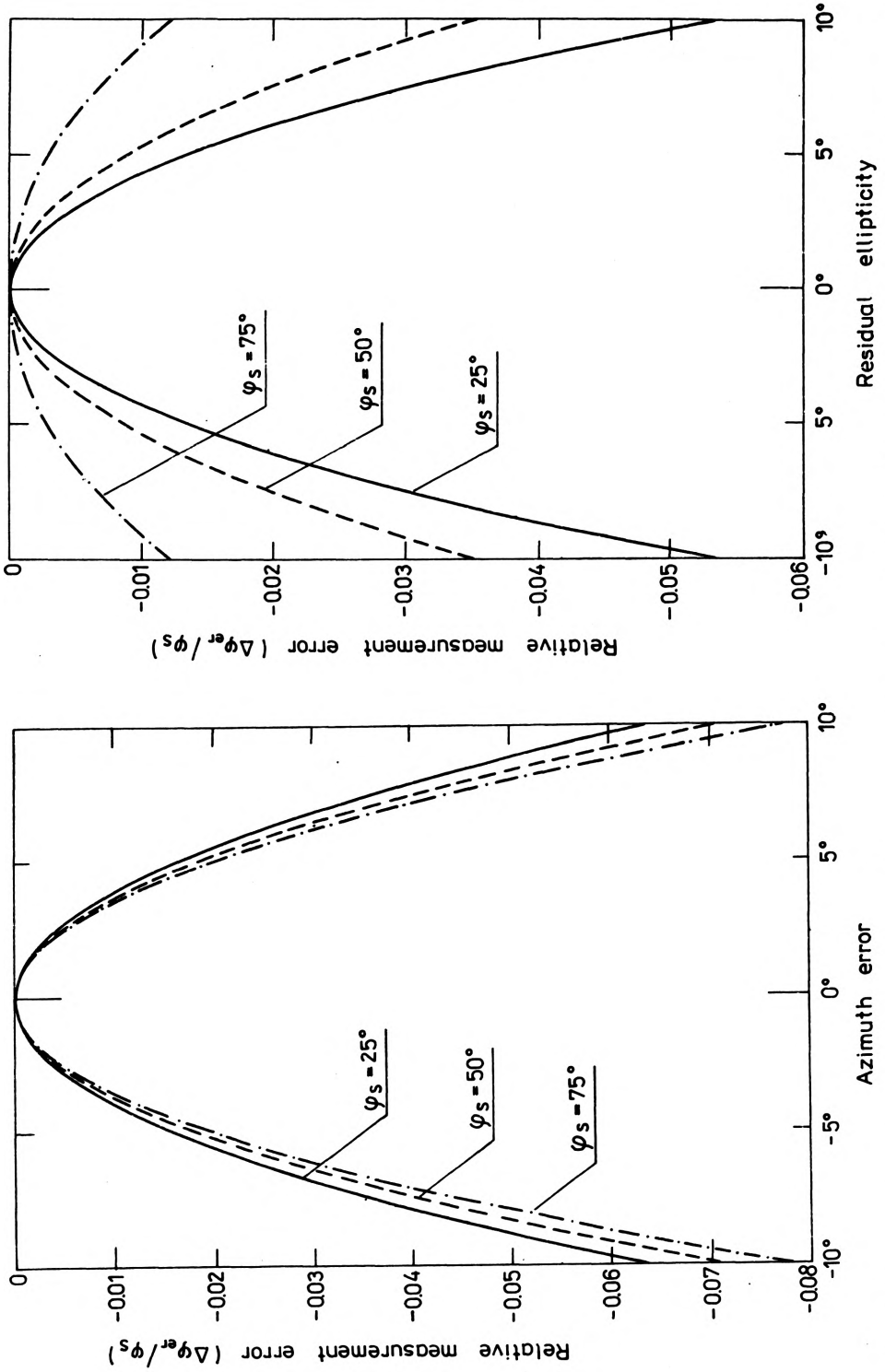

Fig. 4. Relative measurement error ($\Delta\varphi_{er}/\varphi_s$) vs. the misalignment (a) and the residual ellipticity (b) of the birefringent sample. Calculations were made for different values of the phase shift φ_s

for Mueller notation, has been extended also on the Jones notation. The harmonic components of the coherency matrix, the Jones vector as well as the Jones matrix have been defined and their basic properties described.

Particular attention has been paid to the case of measuring system with a single periodical modulator. It was possible to derive simple analytical expressions for the amplitudes I_k and phase shifts φ_k (Eqs. (25a, b)) of any harmonic components of the output intensity. These results are of major importance in practice, since I_k and φ_k are most often directly measured. Knowing the formulas (25), it is possible to estimate systematic errors of measurements caused by individual elements of measuring system. This was demonstrated by the example of the birefringence measuring system with linear phase modulation. The advantages of the error analysis using the proposed Fourier formalism are as follows:

i) The derived formulas (Eq. (34) and (35)) are general, i.e., they can be applied to the class of measuring systems with the same modulation and detection technique as for example polarimeters, interferometers, etc. Only the sequence of the Jones matrices in Eqs. (34) and (35) should be replaced in order to correspond to the measuring system being analysed.

ii) Since the differential Jones matrices have been defined, it is possible to determine the exact as well as the first order measurement errors.

iii) Since the errors are expressed by the Jones matrices representing individual elements of the measuring system, they can be easily calculated by means of matrix-oriented software.

It should be also underlined that the proposed Fourier representation for Jones notation has one important disadvantage. It is useful for error analysis of measuring system with the linear modulators (as in the example) rather than with sinusoidal ones. The Fourier spectrum of the linear modulators is finite (Eq. (29)) and due to this fact we avoid the infinite summation in Eqs. (25). For the measuring system with sinusoidal phase modulation, the Mueller notation should be recommended. It deals directly with intensity (not amplitudes) and in formulas (25) the infinite summation does not occur.

Appendix A

The properties of the Fourier transform of matrix functions will be discussed in this Appendix. First, a definition of convolution and the cross-correlation, generalized over the case of matrix functions, will be presented.

Convolution and cross-correlation defined as [15]

$$f(\omega) \times g(\omega) = \int_{-\infty}^{\infty} f(\omega') g(\omega - \omega') d\omega', \quad (\text{A1})$$

$$f(\omega) \star g(\omega) = \int_{-\infty}^{\infty} f(\omega') g^*(\omega' - \omega) d\omega', \quad (\text{A2})$$

is often used in the Fourier analysis of scalar signals. The above definitions can be generalized over the case of matrix functions used to represent the polarizing elements. A matrix convolution and cross-correlation will be defined as

$$\hat{f}(\omega) \times \hat{g}(\omega) = \int_{-\infty}^{\infty} \hat{f}(\omega') \hat{g}(\omega - \omega') d\omega', \quad (\text{A3})$$

$$\hat{f}(\omega) \star \hat{g}(\omega) = \int_{-\infty}^{\infty} \hat{f}(\omega') \hat{g}^\dagger(\omega' - \omega) d\omega', \quad (\text{A4})$$

where the dimensions of matrices \hat{f} and \hat{g} are equal to $l \times k$ and $k \times m$, respectively, and the symbol \dagger denotes the Hermitian adjoint of matrix. It can be easily proved that matrix convolution and matrix cross-correlation have the properties almost identical to their scalar equivalents.

The majority of theorems referring to the Fourier transform of scalar functions can be generalized over the case of matrix functions applied in the description of polarization phenomena. The Table presents a few of those theorems that are of major importance. Only some of them have been used in the present paper.

Theorems referring to the Fourier transformation of matrix functions

Theorems of:	Time-domain ($\hat{F}(t)$)	Frequency-domain ($\hat{f}(\omega)$)
1. Similarity	$\hat{F}(qt)$	$\frac{1}{q} \hat{f}\left(\frac{\omega}{q}\right)$
2. Addition	$\hat{F}(t) + \hat{G}(t)$	$\hat{f}(\omega) + \hat{g}(\omega)$
3. Translation	$\hat{F}(t - t_0)$	$e^{-i2\pi t_0 \omega} \hat{f}(\omega)$
4. Modulation	$\cos ut \hat{F}(t)$	$\frac{1}{2} \hat{f}\left(\omega - \frac{u}{2\pi}\right) + \frac{1}{2} \hat{f}\left(\omega + \frac{u}{2\pi}\right)$
5. Convolution	$\hat{F}(t) \hat{G}(t)$	$\hat{f}(\omega) \times \hat{g}(\omega)$
6. Correlation	$\hat{F}(t) \hat{G}^\dagger(t)$	$\hat{f}(\omega) \star \hat{g}(\omega)$
7. Derivative	$d\hat{F}(t)/dt$	$i2\pi\omega \hat{f}(\omega)$
8. Derivative of convolution	$\frac{d}{dt} [\hat{F}(t) \times \hat{G}(t)] = \frac{d\hat{F}(t)}{dt} \times \hat{G}(t) + \hat{F}(t) \times \frac{d\hat{G}(t)}{dt}$	

Proofs of the above theorems are analogous to the scalar case [15]. Generalization of the convolution and the cross-correlation over matrix functions can also be defined on the basis of Kronecker product (direct product) of matrices. In this paper, convolution and correlation in the sense of Kronecker, are understood as

$$\hat{f}(\omega) \otimes \hat{g}(\omega) = \int_{-\infty}^{\infty} \hat{f}(\omega') \circ \hat{g}(\omega - \omega') d\omega', \quad (\text{A5})$$

$$\hat{f}(\omega) \oplus \hat{g}(\omega) = \int_{-\infty}^{\infty} \hat{f}(\omega') \circ \hat{g}(\omega - \omega') d\omega', \quad (\text{A6})$$

where \circ denotes the Kronecker product of the matrices. It can be shown that theorems 5–7 hold true also when the convolution and matrix correlation understood in a conventional way (formulae (A1) and (A2)) have been substituted by the convolution and correlation in the Kronecker sense.

Appendix B

The Jones matrix of birefringent elliptic dichroic media can be found in [11] and [16]. For the zero azimuth of the faster eigenwave, we have

$$\hat{T}_0(k, \vartheta, \gamma) = \begin{bmatrix} k \exp(-j\gamma) \sin^2 \vartheta + \cos \gamma, & -0.5j \sin^2 \vartheta [1 - k \exp(-j\gamma)] \\ 0.5j \sin 2\vartheta [1 - k \exp(-j\gamma)], & \sin^2 \vartheta + k \cos^2 \vartheta \exp(-j\gamma) \end{bmatrix}, \quad (\text{B1})$$

and in the general case

$$\hat{T}(k, \vartheta, \gamma, \alpha) = \hat{R}(\alpha) \hat{T}_0 \hat{R}(-\alpha) \quad (\text{B2})$$

where

$$\hat{R}(\alpha) = \begin{bmatrix} \cos \alpha, & \sin \alpha \\ -\sin \alpha, & \cos \alpha \end{bmatrix}, \quad k = \frac{k_s}{k_f}, \quad (\text{B3})$$

and k_s, k_f indicate the amplitude transmission coefficients for slower and faster eigenwaves; γ is the phase retardation between faster and slower eigenwaves; α, ϑ is the azimuth and ellipticity of the faster eigenwave, respectively.

The Jones matrices of individual elements of measuring system can be found by substitution into Eq. (B1) respective values $k_i, \vartheta_i, \gamma_i, \alpha_i$, where the index i indicates ideal matrix. However, every real element of a measuring system is charged with the errors $dk, d\vartheta, d\gamma, d\alpha$. If they are small, we can apply the first order approximation to find the Jones matrix of the real element

$$\hat{T}^{\text{er}}(k, \vartheta, \gamma, \alpha) = \hat{T}(k_i, \vartheta_i, \gamma_i, \alpha_i) + \frac{\partial \hat{T}}{\partial k} dk + \frac{\partial \hat{T}}{\partial \vartheta} d\vartheta + \frac{\partial \hat{T}}{\partial \gamma} d\gamma + \frac{\partial \hat{T}}{\partial \alpha} d\alpha \quad (\text{B4})$$

where $\partial \hat{T} / \partial x$ for $x = (k, \vartheta, \gamma, \alpha)$ are the differential Jones matrices. In this Appendix, the analytical form of the differential Jones matrices in the most general case were found. After differentiating Eq. (B2) we get:

i) for the azimuth

$$\frac{\partial \hat{T}}{\partial \alpha} = \frac{\partial \hat{R}(\alpha)}{\partial \alpha} \hat{T}_0 \hat{R}(-\alpha) + \hat{R}(\alpha) \hat{T}_0 \frac{\partial \hat{R}(-\alpha)}{\partial \alpha} \quad (\text{B5})$$

where

$$\frac{\partial \hat{R}(\alpha)}{\partial \alpha} = \begin{bmatrix} -\sin \alpha, & \cos \alpha \\ -\cos \alpha, & -\sin \alpha \end{bmatrix}, \quad \frac{\partial \hat{R}(-\alpha)}{\partial \alpha} = \begin{bmatrix} -\sin \alpha, & -\cos \alpha \\ \cos \alpha, & -\sin \alpha \end{bmatrix};$$

ii) for the phase retardation

$$\frac{\partial \hat{T}}{\partial \gamma} = \hat{R}(\alpha) \frac{\partial \hat{T}_0}{\partial \gamma} \hat{R}(-\alpha) \quad (\text{B6})$$

where

$$\frac{\partial \hat{T}_0}{\partial \gamma} = k \exp(-j\gamma) \begin{bmatrix} -j \sin^2 \vartheta, & -0.5 \sin 2\vartheta \\ 0.5 \sin 2\vartheta, & -j \cos^2 \vartheta \end{bmatrix};$$

iii) for the ellipticity

$$\frac{\partial \hat{T}}{\partial \vartheta} = \hat{R}(\alpha) \frac{\partial \hat{T}_0}{\partial \vartheta} \hat{R}(-\alpha) \quad (\text{B7})$$

where

$$\frac{\partial \hat{T}_0}{\partial \vartheta} = (1 - \exp(-j\gamma)) \begin{bmatrix} -\sin 2\vartheta, & -j \cos 2\vartheta \\ j \cos 2\vartheta, & \sin 2\vartheta \end{bmatrix};$$

iv) for the extinction ratio

$$\frac{\partial \hat{T}}{\partial k} = \hat{R}(\alpha) \frac{\partial \hat{T}_0}{\partial k} \hat{R}(-\alpha) \quad (\text{B8})$$

where

$$\frac{\partial \hat{T}_0}{\partial k} = \exp(-j\gamma) \begin{bmatrix} \sin^2 \vartheta, & 0.5 j \sin 2\vartheta \\ -0.5 j \sin 2\vartheta, & \cos^2 \vartheta \end{bmatrix}.$$

Verified by Hanna Basarowa

References

- [1] URBAŃCZYK W., PIETRASZKIEWICZ K., *Opt. Appl.* **18** (1988), 237.
- [2] URBAŃCZYK W., *Appl. Opt.* **27** (1988), 973.
- [3] O'HANDLEY R. C., *J. Opt. Soc. Am.* **63** (1973), 523.
- [4] ASPNES D. E., *J. Opt. Soc. Am.* **64** (1974), 639.
- [5] ASPNES D. E., *J. Opt. Soc. Am.* **64** (1974), 812.
- [6] AZZAM R. M. A., BASHARA N. M., *J. Opt. Soc. Am.* **64** (1974), 1459.
- [7] STRAALIER A., HONEKAMP L. J., BOOTSMA G. A., *Surface Sci.* **96** (1980), 217.
- [8] KAWABE S., *J. Opt. Soc. Am.* **A4** (1987), 664.
- [9] KAWABE S., *J. Opt. Soc. Am.* **A1** (1984), 706.
- [10] URBAŃCZYK W., *Fourier representation of time-dependent polarizing system*, *J. Modern Optics* (submitted for publication).
- [11] AZZAM R. M. A., BASHARA N. M., *Ellipsometry and Polarized Light*, North-Holland Publ. Co., Amsterdam, New York, Oxford 1977.

- [12] WOOD I. G., GLAZER A. M., J. Appl. Crystallogr. 13 (1980), 217.
- [13] URBAŃCZYK W., Opt. Appl. 18 (1988), 253.
- [14] URBAŃCZYK W., PIETRASZKIEWICZ K., WOŹNIAK W. A., Opt. Appl. 18 (1988), 121.
- [15] BRACEWELL R., *The Fourier Transform and Its Applications*, McGraw-Hill, New York 1965.
- [16] ŚCIERSKI I., RATAJCZYK F., Optik 68 (1984), 121

Received March 15, 1991

Гармонический анализ временно зависимых поляризационных систем в нотации Джонса

Модуляция состояния поляризации в настоящее время широко применяется в оптических измерительных системах. Каждая измерительная система состоит из отдельных поляризационных элементов, которые можно описать при помощи матриц Мюллера или Джонса. Гармонический анализ, предложенный раньше для нотации Мюллера, расширен в настоящей статье также на нотацию Джонса. Определены гармонические ответы матрицы Джонса, матрицы когеренции, вектора Джонса и описаны их основные свойства. Определены также гармонические матрицы наиболее часто употребляемых модуляторов. Даны аналитические формулы, определяющие амплитуды, а также сдвиги по фазе для отдельных гармонических составных элементов конечного напряжения пучка, выходящего из измерительной системы с одиночным модулятором. Пригодность гармонического анализа для определения систематических погрешностей измерения была представлена на примере системы для измерения двойного лучепреломления с линейной модуляцией фазы. Определены дифференциальные матрицы Джонса, дающие возможность первичного анализа систематических погрешностей измерения.

Перевел Станислав Ганцаж