

Examination of air density fluctuations with the aid of laser beam

KATARZYNA KLEMM¹, KRZYSZTOF PIESZYŃSKI², KAZIMIERZ ROŻNIAKOWSKI²

¹Institute of Architecture and Urban Planning, Technical University of Łódź,
al. Politechniki 6, 90-924 Łódź, Poland

²Institute of Physics, Technical University of Łódź, ul. Wólczańska 219, 90-924 Łódź, Poland

The paper presents theoretical foundations and results of experimental verification of the possibility of laser beam application for registration of air density fluctuations caused either by mechanically forced air flow near obstacles which are not streamlined or by the presence of solid objects which produce thermal disturbance (temperature gradients).

Keywords: turbulence, density fluctuations, laser application.

1. Introduction

Measurements of density of matter, *i.e.*, the number of molecules in unit volume, are constantly developed and refined for different experimental situations. Air density fluctuations caused either by mechanically forced gas flow near non-streamlined obstacles or by the presence of solid objects (buildings) which produce thermal disturbance (temperature gradients) deserve special interest. There are many different, indirect methods of detection of gas density fluctuations. It can be realized, just to mention only a few possibilities, by monitoring the temperature of heated probes (thermo-anemometric sensors [1]) or by determination of whirls frequency near some specially shaped, non-streamlined, sharp edged elements [2]. Each of those methods has its special features which make it most suitable for specific applications. These features are connected with the obtained precision, time delay or spatial resolution. It must be remembered that all these methods make use of different probes which, to some extent, always introduce certain disturbance of temperature and flow conditions, just by their presence.

It seems that the technique which makes use of laser beam and its speckles as a probe, does not introduce any disturbance of the observed process [1, 3]. Moreover, the time

delay in this case is incomparably smaller than for other methods, which makes it especially useful for the examination of rapid changes of gas.

The authors of this paper wanted to examine the effect of air density fluctuations caused by forced air flow or by temperature gradients on the intensity of laser beam which propagates in such conditions.

2. Theoretical foundations

The fact that the refractive index of gas, especially of air, depends on the number of molecules in unit volume is confirmed by the results of many experiments. As an example one can discuss the experiments with Michaelson interferometer and a tube of gas (carbon dioxide) placed in one of its arms. The gas pressure is changed for constant temperature and consequently the concentration of gas molecules changes, too. The change in concentration of gas molecules is followed by translation of the interference fringes in one direction (or switching of bright and dark fringes), which proves that the increasing density of the gas results in bigger values of its refractive index [4].

Theoretical dependence of the refractive index value on the density of molecules is described by Lorenz–Lorentz formula [5]

$$\frac{n^2 - 1}{n^2 + 2} = c \text{const}(\alpha) \quad (1)$$

where: n – the refractive index of gas (air), c – density of gas molecules (the number of molecules per unit volume), $\text{const}(\alpha)$ – the coefficient dependent on the mean polarizability of isotropic molecule.

Because $(n^2 - 1) = (n - 1)(n + 1)$ and assuming $n = 1.0002929$ (for the air at 14.5 °C and for D line of sodium), after simple transformation of this formula, one obtains:

$$n \approx \frac{3}{2} c \text{const}(\alpha) + 1 \quad (2)$$

Equation (2) shows that there is a linear dependence of the refractive index n for air on the concentration of molecules c .

If there is no flow of gas, especially in conditions of thermal equilibrium, local fluctuations of density are relatively small. The situation changes when the gas flows, especially close to the objects obstructing its flow, or when heat is exchanged between the gas and these objects.

Clapeyron's equation can be used as a starting point to describe qualitatively the influence of the above-mentioned factors [6]:

$$pV = \frac{N}{N_A} RT \quad (3)$$

where: R – gas constant, p – pressure of the gas, V – volume of the gas, N – number of molecules in the gas, N_A – Avogadro's number, T – gas temperature in kelvins. Equation (3) transforms into:

$$\frac{N}{V} = \frac{N_A p}{RT} \quad (4)$$

having in mind that:

$$c = \frac{N}{V} \quad (5)$$

and making use of the relation between gas constant R , Avogadro's number N_A and Boltzmann constant $k = R/N_A$ one obtains the dependence of the concentration of molecules on pressure and temperature:

$$c = \frac{p}{kT} \quad (6)$$

To sum up the above derivations it can be stated that in any gaseous medium, even when as a whole it remains in thermal equilibrium, small fluctuations of density are always present as a result of random motions of molecules. Local disturbances caused by applying pressure difference or heating are the source of additional and much stronger stimuli generating new regions with changed density and (according to Eq. (6)) changed value of the refractive index. The local disturbance of pressure, mentioned above, can occur when, for instance, the air stream collides with an obstacle (or goes by). It is obvious that when the obstacle has different temperature than the gas, it can cause local density changes even without any gas movement.

The laser beam propagating in the medium with gradients of refractive index (connected with density fluctuations F – dark and bright regions in Fig. 1) undergoes

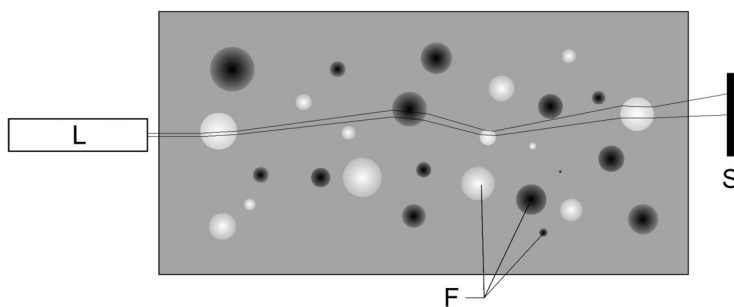

Fig. 1. Propagation of the laser beam (emitted by laser L) in the gaseous medium with local fluctuations of density F (bright and dark regions). In reality, deflection and defocusing of the laser beam are much more subtle effects than in this figure, where they are purposely rendered bigger, to make the picture more clear.

local distortions of its electric field strength vector amplitude and phase. It finally results in changes of light intensity distribution across the beam and temporal changes of light intensity at a chosen point of the beam's cross-section observed on the screen S. The effects described are schematically illustrated in Fig. 1.

Analysis of the data obtained must make use of statistical methods because of the random nature of time and spatial fluctuations of air density which influence the propagation of the laser beam. Statistical parameters [7], which best render the character of the obtained results are (X_M – mean value, X_{RMS} – standard deviation):

$$X_M = \frac{\sum_{i=1}^{N_t} x_i}{N_t} \quad (7)$$

$$X_{RMS} = \sqrt{\frac{\sum_{i=1}^{N_t} (x_i - X_M)^2}{N_t}} \quad (8)$$

where: x_i – a result of one measurement, N_t – total number of measurements in a series.

3. Experimental setup

As a source of light the authors used a diode laser of power 14 mW and a wavelength of 640 nm with additional lenses to make the beam quasi-parallel (along a distance of about 1.5 m). Two photodiodes, type BPYP17, were applied for the measurements of light intensity. One of them (PD1) monitored the intensity of the beam emitted by the laser. It was placed in one casing together with the laser L and the beam-splitter plate BS. The other one, positioned behind a diaphragm of 0.1 mm in diameter measured the intensity of light beam which went across the tunnel.

The laser and the photodiode were aligned on the same, heavy optic bench to minimize mechanical vibrations. There was no mechanical contact between the laser, the photodiode PD2 and the wind tunnel to avoid influence of vibrations on the intensity measurements.

The laser beam crossed a wind tunnel perpendicularly to the tunnel axis passing through two small holes made in the wall of the tunnel at a distance $h = 4$ cm from its base and $L = 150$ cm from four fans which forced air to flow. The electric signal from the photodiodes was connected to a computer controlled 16 bit A-C converter with memory (ADC). This system registered the intensity of light sampled with constant interval of 50 ms and the duration of the whole measurement was 5 μ s. A special program applied could store about 32 thousands of intensity values.

After the measurements data were sent via RS232 port to the computer. Figure 2 presents a diagram of the experimental system.

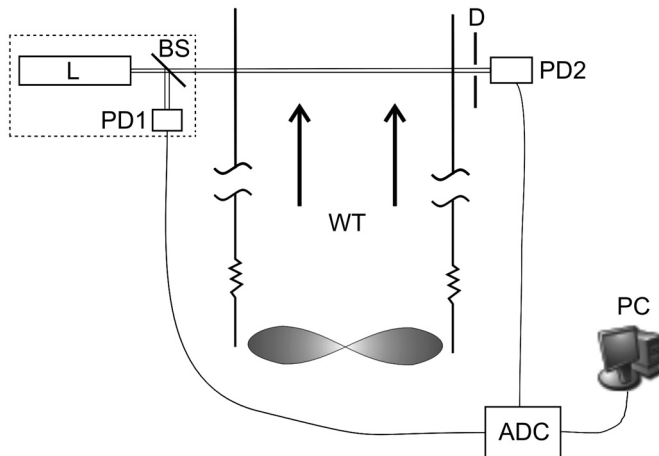

Fig. 2. The diagram of the experimental system: L – diode laser with additional lenses, PD1 – photodiode, BS – beam splitter, PD2 – photodiode with the diaphragm D, WT – axial-flow fan of the wind tunnel, ADC – analog-digital converter with memory, PC – computer. The figure does not render real proportions for obvious reasons.

The idea of applying laser beam for the detection of local density fluctuations near the obstacles which change the conditions of flow is based on the assumption that density fluctuations generated in this situation are big enough to cause a detectable change of propagation in comparison with the propagation in still air in conditions of thermal equilibrium between the gas and the solid objects.

4. Results of the experiment

4.1. Examinations of the measuring system stability

In real situations, the fluctuations of air density are very small even for turbulent flows, so the measuring system must be characterized by a very stable and low noise operation. This requirement applies especially to the laser and the detecting system.

The upper curve in Fig. 3 presents the registered signal from the photodiode PD1 (intensity of the laser beam before it enters the wind tunnel), while the lower one shows the signal from the photodiode PD2 illuminated with the beam after it goes across the tunnel. Both intensities fluctuate but the air in the wind tunnel is still and there are no heat sources in its neighbourhood.

The upper curve is for the case when the photodiode was placed close to the laser and the lower one for the detector placed 1 m (width of the tunnel) from the laser at the point where it remains during the experiment. The time interval between subsequent measurements was 0.1 s. The lack of clear differences between two curves from Fig. 3 indicates that the air density fluctuations were negligible or too small to be detected by this experimental system.

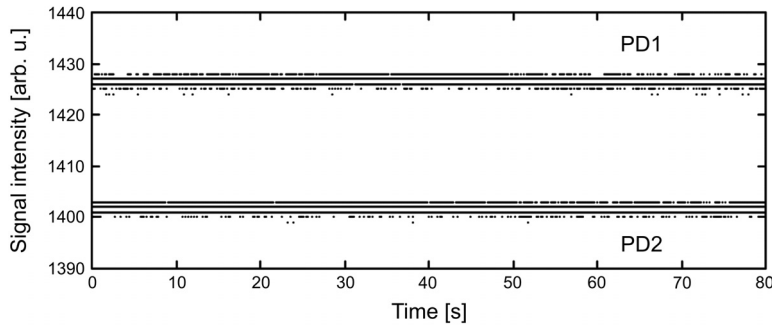

Fig. 3. The dependence of the signals from the photodiodes, PD1 (the upper curve) and PD2 (the lower curve), as a function of time when the air in the wind tunnel is still.

A discrete character of the results presented by the two curves is due to the properties of the applied A-C converter – its sampling time was 50 ms. This and the fact that the points for subsequent moments are not connected explains why there are apparent parallel lines on the diagram. Vertical spacing between these lines is determined by the A-C converter sensitivity (1 mV). This sensitivity proves to be adequate for the measurements described. Standard deviation X_{RMS} for signals from photodiodes PD1 and PD2 is 0.6209 and 0.6208, respectively.

All the measurements were conducted after the instruments reached the conditions of thermally stable operation.

4.2. Unobstructed flow of air

Then, similar measurements were conducted with moving air for the velocity of the wind in the tunnel equal to 2 m/s at the height $h = 4$ cm from its base and $L = 150$ cm from the fans, in the place where the light beam crosses the stream of flowing air.

Figure 4 presents the fluctuations of light intensity measured with the photodiode PD2 in this case. The value of standard deviation X_{RMS} is 6.8966.

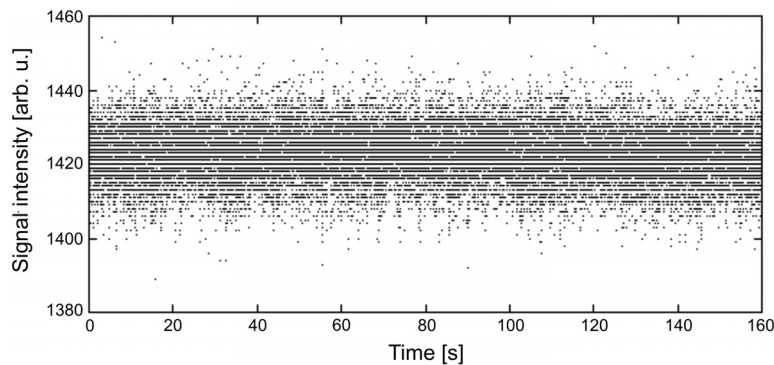

Fig. 4. The signal from PD2 photodiode versus time, for the velocity of air in the tunnel $v = 2$ m/s.

4.3. Flow of air in the presence of obstacles

The next measurement was conducted for the situation when 20 cm high obstacle ($h_p = 20$ cm) was placed at a distance $d = 0.5$ cm, perpendicularly to the tunnel axis and completely blocked the air flow in the lower part of the wind tunnel.

Intensity of the beam crossing the wind tunnel was measured every 50 ms. The results are presented in Fig. 5a. The value of standard deviation X_{RMS} is 8.128. The height of the laser beam above the tunnel's base was the same as in Sec. 4.2.

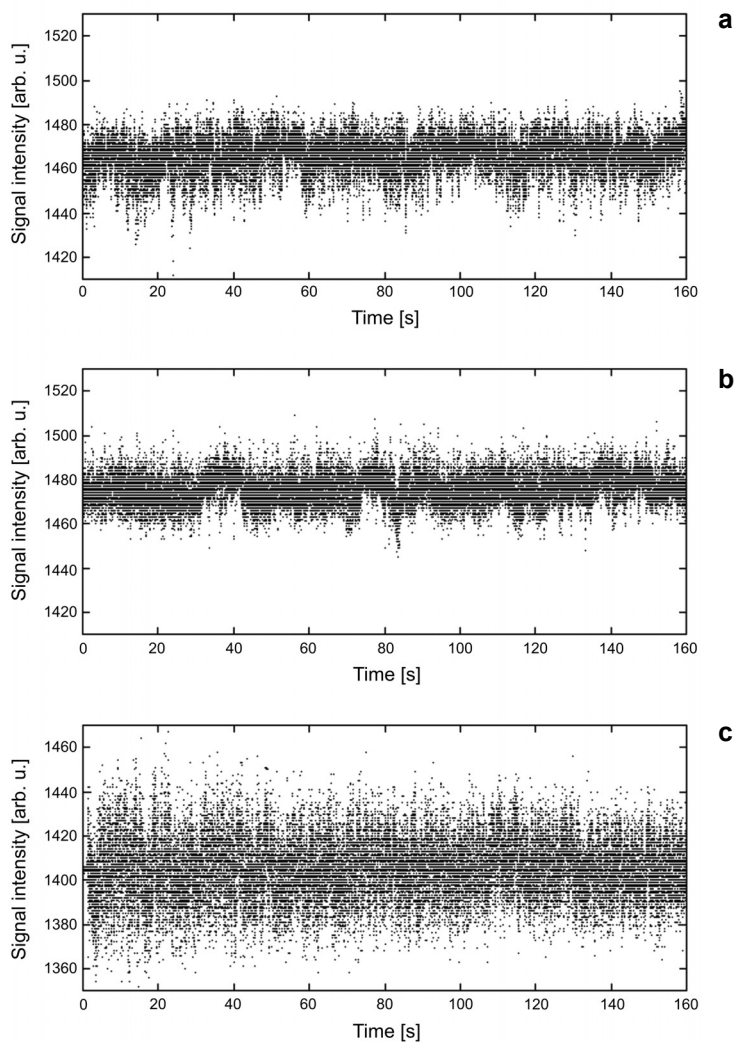

Fig. 5. The dependence of the PD2 photodiode signal as a function of time when the air in the wind tunnel moves with velocity 2 m/s and: a 20 cm high obstacle in the tunnel placed 0.5 cm from the laser beam (a), a 20 cm high obstacle in the tunnel placed 10 cm from the laser beam (b), and a 40 cm high obstacle in the tunnel placed 94 cm from the laser beam (c).

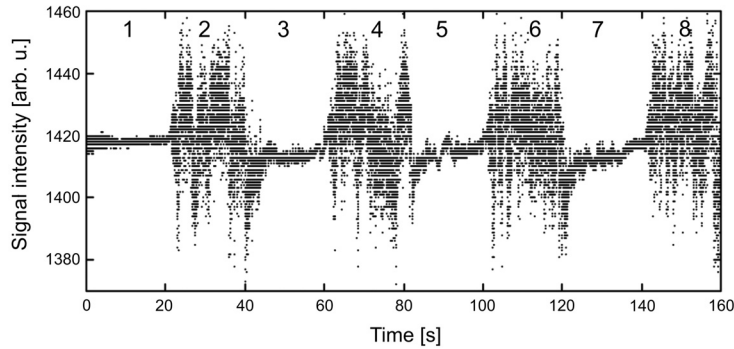

Fig. 6. The dependence of the PD2 photodiode signal as a function of time when the air in the wind tunnel moves with velocity 2 m/s with periodic operation of the fans (every 20 s) and there is a 40 cm high obstacle in the tunnel, placed 94 cm from the laser beam.

Then, for unchanged path of the beam across the tunnel, the obstacle ($h_p = 20$ cm, perpendicular to the tunnel axis and completely blocking the air flow in the lower part of the wind tunnel) was placed at $d = 10$ cm in front of the laser beam. The results of measurements are presented in Fig. 5b. The obtained value of standard deviation was $X_{\text{RMS}} = 6.822$.

In the third measurement, the obstacle was bigger ($h_p = 40$ cm) and was placed 94 cm from the beam, still completely blocking the flow of air in the lower part of the tunnel. The results are presented in Fig. 5c. This time standard deviation of registered fluctuations was $X_{\text{RMS}} = 14.036$.

In the next step, for the same geometrical conditions, the flow of air was switched on every 20 s. The fluctuations of light intensity were measured every 50 ms and the results are presented in Fig. 6. The values of standard deviation in subsequent

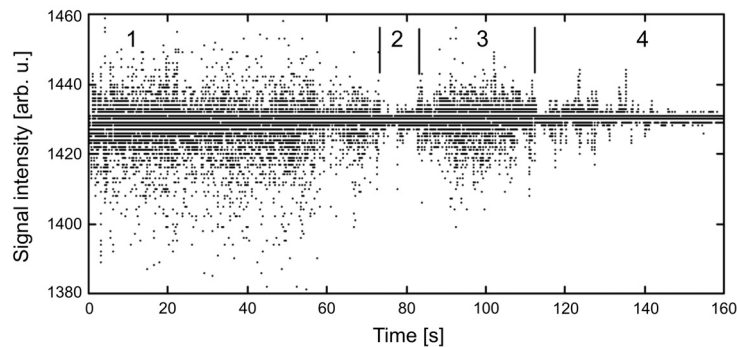

Fig. 7. The dependence of the PD2 photodiode signal as a function of time when the fans in the wind tunnel are switched off but a heater (36 °C) is placed near the laser beam.

time intervals (indicated in Fig. 6) are: 0.949 (1), 12.103 (2), 1.475 (3), 12.794 (4), 1.998 (5), 12.758 (6), 2.409 (7), 12.976 (8).

4.4. Heat source

The next measurements of light intensity fluctuations were conducted when the air in the wind tunnel was still but warm object (36 °C) was drawn near the laser beam and then removed. The temperature in the tunnel was 21 °C. The light intensity was measured every 50 ms. The values of standard deviation for the measured signal are: 6.023 (1) – the heat source close to the beam, 1.475 (2) – the heat source moved away from the beam, 4.212 (3) – the heat source close to the beam, 1.604 (4) – the heat source is moving away from the beam (Fig. 7).

5. Summary and conclusions

It is clearly seen from the measurements conducted with the air flowing in the wind tunnel that there are significant differences in the values of standard deviation for fluctuations of light intensity detected with PD1 and PD2 photodiodes.

Different values of standard deviation for the measurements presented on subsequent diagrams prove that X_{RMS} value can be used in examinations of air movements at certain points. This is most clear when they are compared for still air and when air movements are induced mechanically or thermally.

The authors described introductory investigation into the possibility of applying lasers in examination of air density fluctuations close to various objects which obstruct the flow.

Results of the measurements presented prove with no doubt that with this method parameters of air flow can be examined with a short time delay and without any additional disturbance of the processes observed. It makes this method especially suitable for the measurements of air fluctuations and dynamics for various phenomena in the close vicinity of different buildings and constructions (which cause temperature gradients and density fluctuations of air). This gives the basis for better understanding (and then application) of the complicated processes of air flow and heat exchange.

References

- [1] KLEMM P., ROŻNIAKOWSKI K., JABŁOŃSKI M., KLEMM K., [In] Materiały Konferencyjne IX Polskiej Konferencji Naukowo-Technicznej *Fizyka Budowli w teorii i praktyce*, Łódź 2003, p. 287 (in Polish).
- [2] SYDENHAM P., THORN R. [Eds.], *Handbook of Measurement Science*, Vol. 2, Wiley, 1983.
- [3] KLEMM P., ROŻNIAKOWSKI K., WOJTATOWICZ T. W., KLEMM K., [In] Materiały Konferencyjne VIII Polskiej Konferencji Naukowo-Technicznej *Fizyka Budowli w teorii i praktyce*, Łódź 2001, p. 278 (in Polish).

- [4] DROBNIK A., KEPSKI B., ROŻNIAKOWSKI K., *Application of Michelson type interferometer for the measurements of second virial coefficient of molecular refraction*, Acta Universitatis Lodzianis, Folia Physica 10, 1987, p. 135.
- [5] BORN M., WOLF E., *Principles of Optics*, Cambridge University Press, Cambridge 1999.
- [6] WEICHEL H., *Laser Beam Propagation in the Atmosphere*, Vol. TT3, SPIE Press Book, 1990.
- [7] BRANDT S., *Data Analysis, Statistical and Computational Methods for Scientists*, Springer-Verlag, New York 1999.

Received July 19, 2006