

Fine structure of heterogeneous vector field and its space averaged polarization characteristics

R. BRANDEL, A. MOKHUN, I. MOKHUN, Ju. VIKTOROVSKAYA

Chernivtsy National University, 2 Kotsybinsky Str., Chernivtsy 58012, Ukraine

Interrelation between the fine structure of the vector field and its averaged polarization characteristics is considered. It is shown that space averaged Stokes parameters are defined by dispersion of the phase difference (or dispersion of the polarization azimuth) at its saddle points. At the same time the dispersion of the phase difference is directly related to averaged space between the nearest adjacent component vortices of the same sign, which are associated with the different orthogonal linearly polarized components. The dependence between the dimensions of areas where considerable polarization changes occur and averaged space between the nearest adjacent component vortices of the same sign is obtained. The results of computer simulation and the experimental investigation are presented.

Keywords: vortex, polarization, polarization singularities, coherence matrix, Stokes parameters, phase dispersion, s -contour, C -point, phase difference, integral depolarization.

1. Introduction

Historically, conventional polarization parameters such as Stokes ones and coherence matrix [1, 2], which characterize a vector field were introduced for light beams, and in particular for incoherent light beams. Thus, a conventional approach to their determination requires integration of measured values by the space coordinates and time. The question arises of whether it is possible to introduce similar parameters for each field point of the space and for each time moment?

It is absolutely obvious that such an operation is rightful for completely coherent waves [1, 3, 4]. Naturally, the coherence of monochromatic beam, to a greater or lesser extent, decreases under the interaction with scattering object. But the large type of objects characterized by single scattering practically does not destruct the coherence. The beam coherence length after the scattering by such objects slightly diminishes the relative coherence length of the beam of modern laser. Thin polymer films [5], small parts of multimode fibers [6] are good examples of such objects. In other words, though the field behind single scattering objects is formed as speckle one it remains absolutely polarized due to the preservation of coherence. At the same time polarization parameters, such as Stokes ones and coherence matrix, measured for a full beam will

be similar to those of a completely or partially depolarized wave. This happens due to different polarizations at each field point.

Thus, the conclusion can be drawn about some analogy between the behavior of conventional parameters measured for partially coherent fields and similar space-averaged ones measured for heterogeneous polarization fields. This follows from the fact that exchanging the averaging-out by time for the averaging-out with respect to space coordinates is possible [7]. Due to the linearity of the averaging operation the averaged Stokes parameters, elements of coherence matrix, *etc.*, are integrals according to analyses square from corresponding local parameters.

The question arises of how such averaged parameters are related to the characteristics of special structures of vector field like polarization singularities, field areas with saddle points of polarization parameters, *etc.*, which form some skeleton of the field [4, 8–17] and define the field behavior at each point? In this paper, it has been attempted to establish such relationships.

2. Space averaged Stokes parameters

Let us consider Stokes parameters \bar{s}_i ($i = 0, 1, 2, 3$) obtained from experimental data. It is well known [1, 2] that every Stokes parameter \bar{s}_i may be obtained as some combination of the corresponding measured intensity parameters

$$\bar{s}_i = \bar{I}_{i1} + \bar{I}_{i2} \quad (1)$$

where \bar{I}_{ik} is a magnitude averaged over the photodetector square q_f :

$$\bar{I}_{ik} = \int_{q_f} I_{ik} dx dy \quad (2)$$

where I_{ik} is a local intensity at some field point. It can be assumed (at least for paraxial approximation) that averaging is carried out on infinitely large square, if the photodetector square q_f is much greater than speckle dimension ($q_f \gg l_{\text{coh}}^2$)

$$\bar{I}_{ik} = \int_{-\infty}^{\infty} \int_{-\infty}^{\infty} I_{ik}(x, y) dx dy \quad (3)$$

It follows from Eqs. (1)–(3) that:

$$\bar{s}_i = \int_{-\infty}^{\infty} \int_{-\infty}^{\infty} s_i(x, y) dx dy \quad (4)$$

where $s_i(x, y)$ is a local Stokes parameter.

3. Analysis of polarization parameters of the field decomposed into linearly polarized components

It is well known [1, 2] that $s_i(x, y)$ may be represented by components of coherence matrix:

$$\begin{cases} s_0 = J_{xx} + J_{yy} \\ s_1 = J_{xx} - J_{yy} \\ s_2 = J_{xy} + J_{yx} \\ s_3 = \frac{1}{j}(J_{xy} - J_{yx}) \end{cases} \quad (5)$$

Let us recall that $J_{xy} = J_{yx}^*$ (Hermitian matrix). It follows from Eqs. (4) and (5) that \bar{s}_i is represented by averaged components of coherence matrix:

$$\bar{J}_{lk} = \int_{-\infty}^{\infty} \int_{-\infty}^{\infty} J_{lk}(x, y) dx dy \quad (6)$$

where $k, l = 1, 2$ correspond to x, y . It is known [1, 2] that

$$J = \begin{vmatrix} \langle E_x E_x^* \rangle & \langle E_x E_y^* \rangle \\ \langle E_y E_x^* \rangle & \langle E_y E_y^* \rangle \end{vmatrix} = \begin{vmatrix} J_{xx} & J_{xy} \\ J_{yx} & J_{yy} \end{vmatrix} \quad (7)$$

where $\langle \rangle$ means averaging in time.

The averaging in time loses the sense if the vector field is coherent and completely polarized. In this case, $J_{kl} = u_k u_l^*$, (u_k is the complex amplitude of orthogonal component) and J_{xy} has the form:

$$J_{xy} = a_x a_y \exp(j\Delta\varphi) \quad (8)$$

where $a_x, a_y, \Delta\varphi$ are the amplitude modules and phase difference of the orthogonal components, correspondingly.

Zeroes of the J_{xy} coincide with those components which are unambiguously related to polarization singularities (s -contours and C -points) [11–13].

The averaged component of the coherence matrix \bar{J}_{xy} is described by the relation:

$$\bar{J}_{xy} = \int a_x a_y \exp(j\Delta\varphi) dx dy \quad (9)$$

which may be interpreted as maximum of the correlation function of the component complex amplitudes. Note that the $\exp(j\Delta\varphi)$ is the fast oscillating function. The maximal speed of the changes $\Delta\varphi$ is observed in the area of the zeroes of the J_{xy} (in the area of component vortices), where the phases of components changed from 0 to 2π over some small area including the vortex center. The $a = a_x a_y$ is also minimal in this area (either a_x or $a_y \rightarrow 0$). The contribution of such regions to the result of (9) is minimal. The areas of the stationary points of $\Delta\varphi$ (saddle points of the phase difference) make the main contribution to Eq. (9). Equation (9) may be approximated by the method of stationary phase [1].

The averaged component of the coherence matrix \bar{J}_{xy} may be represented in the form:

$$\bar{J}_{xy} = \sum_i^N \bar{J}_{ixy} \quad (10)$$

where $\bar{J}_{ixy} = \int_{q_i} J_{xy} dx dy$, q_i is the field region with one saddle point of the phase difference. \bar{J}_{ixy} may be transformed by stationary phase method to the relation:

$$J_{ixy} = \int_{q_i} a_x a_y \exp(j\Delta\varphi) dx dy \approx a_x a_y \exp j\Delta\varphi \Big|_{\substack{x = x_i \\ y = y_i}} \quad (11)$$

where x_i, y_i may be defined as solutions of the following system:

$$\begin{cases} \frac{d\Delta\varphi}{dx} = 0 \\ \frac{d\Delta\varphi}{dy} = 0 \end{cases} \quad (12)$$

These solutions $a_i = a_x a_y \Big|_{\substack{x = x_i \\ y = y_i}}$, $\Delta\varphi_i = \Delta\varphi \Big|_{\substack{x = x_i \\ y = y_i}}$ are the magnitude of the value at the saddle point of phase difference. Then, \bar{J}_{xy} may be approximated by the relation:

$$\bar{J}_{xy} \approx \sum_i^N a_i \exp(j\Delta\varphi_i) \quad (13)$$

where $a_i, \Delta\varphi_i$ are mostly the random Gaussian magnitudes and $\Delta\varphi_i$ may be centred:

$$\Delta\varphi_i = \Delta\varphi_0 + \Delta_i \quad (14)$$

where $\Delta\varphi_0$ is the primary phase difference of orthogonal components, Δ_i is distributed symmetrically about zero. The distribution density of Δ_i is of the Gaussian type:

$$\rho_{\Delta}(\Delta) = \frac{1}{\sqrt{2\pi}\sigma_{\Delta}} \exp\left(-\frac{\Delta^2}{2\sigma_{\Delta}^2}\right) \quad (15)$$

Correspondingly, the characteristic function has the form:

$$M_{\Delta}(\omega) = \exp\left(\frac{\sigma_{\Delta}^2\omega^2}{2}\right) \quad (16)$$

The sum (13) may be estimated as the sum of the random phasors [18].

Let us assume that the vector field is statistically isotropic and may be characterized by correlation radius l_{coh} . After that we will chose the decomposition basis in such a manner that

$$\bar{J}_{xx} = \bar{J}_{yy} \quad (17)$$

i.e., average intensities of the orthogonal components are the same.

Then, $\overline{a_{ix}a_{iy}} = \bar{a}_{ix}\bar{a}_{iy} = I_{\text{comp}}$ (\bar{a}_{ix} , \bar{a}_{iy} – average intensities of orthogonal components) due to the statistical independence of the components.

As follows from [18], $\rho_{\Delta}(\Delta)$ is defined for symmetrical distribution densities by the relation:

$$\begin{cases} \bar{r} = \bar{a}_i M_{\Delta}(1) \\ \bar{i} = 0 \end{cases} \quad (18)$$

where r and i are the real and imaginary parts of the sum:

$$S = \sum_i^N a_i \exp(j\Delta_i) \quad (19)$$

It follows from Eqs. (17)–(19), that:

$$r = I_{\text{comp}} \exp\left(-\frac{\sigma_{\Delta}^2}{2}\right) \quad (20)$$

Then,

$$\bar{J}_{xy} \approx \bar{J}_{xx} \exp(j\Delta\Phi_0) \exp\left(-\frac{\sigma_\Delta^2}{2}\right) \quad (21)$$

For the chosen decomposition basis, the Stokes parameters have the form:

$$\begin{aligned} \bar{s}_0 &= 2\bar{J}_{xx} \\ \bar{s}_1 &= 0 \\ \bar{s}_2 &= 2\bar{J}_{xx} \exp\left(-\frac{\sigma_\Delta^2}{2}\right) \cos(\Delta\Phi_0) \\ \bar{s}_3 &= 2\bar{J}_{xx} \exp\left(-\frac{\sigma_\Delta^2}{2}\right) \sin(\Delta\Phi_0) \end{aligned} \quad (22)$$

where σ_Δ^2 – phase dispersion at the saddle points of phase difference, $\Delta\Phi_0$ – the primary phase difference of orthogonal components, for decomposition basis chosen in such a manner that average intensities of the orthogonal components are the same.

The parameters, normalized to unit, have the form:

$$\begin{aligned} \bar{s}_0 &= 1 \\ \bar{s}_1 &= 0 \\ \bar{s}_2 &= \exp\left(-\frac{\sigma_\Delta^2}{2}\right) \cos(\Delta\Phi_0) \\ \bar{s}_3 &= \exp\left(-\frac{\sigma_\Delta^2}{2}\right) \sin(\Delta\Phi_0) \end{aligned} \quad (23)$$

Obviously, the inequality takes place, as it is true for the partly coherent illumination [1]:

$$\bar{s}_0^2 \geq \bar{s}_1^2 + \bar{s}_2^2 + \bar{s}_3^2 \quad (24)$$

The “integral depolarization” is observed

$$P = \frac{\sqrt{\bar{s}_1^2 + \bar{s}_2^2 + \bar{s}_3^2}}{\bar{s}_0} \quad (25)$$

The equality in Eq. (24) is fulfilled for $\sigma_{\Delta}^2 = 0$ in the case of completely homogeneously polarized field. As follows from (23), space averaged Stokes parameters are defined by dispersion of the phase difference at its saddle points.

Note that σ_{Δ}^2 is related with a magnitude of an averaged space between the nearest adjacent component vortices of the same sign l_{vor} . The σ_{Δ}^2 and l_{vor} are equal to zero for completely correlated components (completely homogeneously polarized field). If σ_{Δ}^2 increases, the l_{vor} increases, too. The limit case is $l_{\text{vor}} = l_{\text{cor}}$ for absolutely integrally depolarized field. Thus, one can state that σ_{Δ}^2 is some function of the l_{vor} . This dependence may be obtained using data from the corresponding computer simulation.

4. Computer simulation and experimental results

It is known that the field in the far zone \mathbf{U}_d (for heterogeneous vector field also) is a Furrier-transform of the field \mathbf{U}_{in} , which is formed immediately after the scattering object [19]. This statement is also satisfied for the orthogonal components of the field. As can be shown for the formation of \mathbf{U}_d field the \mathbf{U}_{in} may be represented as a set of point source with unit amplitude, random phase and positions

$$U_{\text{in}} = \sum_i^N \exp(j\Phi_i) \delta[(x - x_i), (y - y_i)] \quad (26)$$

where N is the number of the point sources, Φ_i, x_i, y_i are the phase and the coordinates of the i -th point source, respectively.

“Input” samples of point sources associated with different orthogonal components are formed by an equal total number of point sources, but they differ by phases and localizations of N_d sources. In this case, the components with equal intensities are formed in the far zone and their correlation coefficient is defined by simple relation

$$\gamma = \frac{N_d}{N} \quad (27)$$

The level of “integral depolarization” D was chosen as polarization parameter characterizing the averaged polarization characteristics of vector field. Note that the field remains completely polarized at each point. It is known that when the condition $\overline{J_{xx}} = \overline{J_{yy}}$ is fulfilled, the integral depolarization is directly related to the correlation coefficient γ of the orthogonal components [1]:

$$D = 1 - \gamma \quad (28)$$

Thus, in our case, γ characterizes the “integral” polarization of the field upon fulfilling the condition $\overline{J}_{xx} = \overline{J}_{yy}$.

The ratio l_V of the space between the nearest adjacent component vortices l_{vor} to correlation length l_{cor} , the maps of phase difference and averaged Stokes parameters were calculated for different levels of integral depolarization.

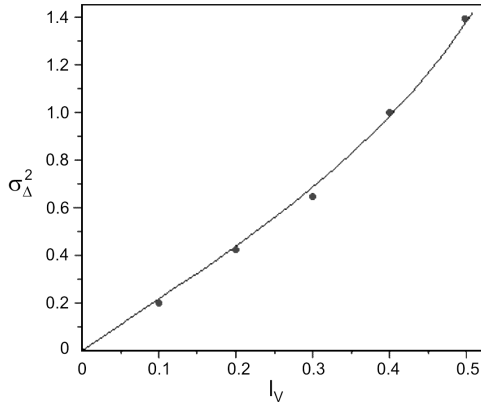

Fig. 1. Dependence of the dispersion of the phase difference σ_{Δ}^2 of linearly polarized orthogonal components on the ratio l_V of the space between adjacent component vortices of the same sign to the correlation length.

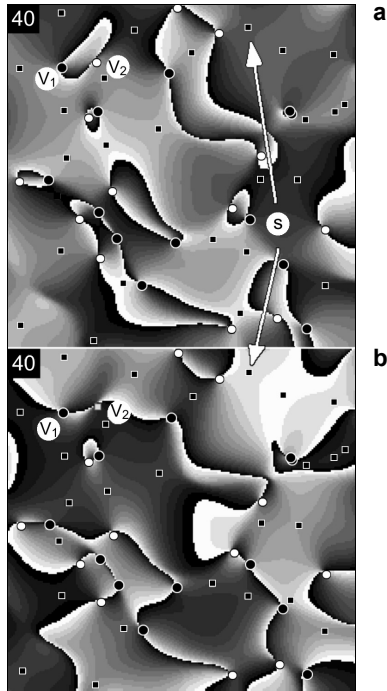

Fig. 2. Maps of phase difference between the linearly polarized orthogonal components for 40% of field “depolarization” for different primary phase differences: $\Delta\Phi_0 = \pi/2$ (a), $\Delta\Phi_0 = 0$ (b). For clarity, the phase difference is presented within π . Phase differences, which differ by $\pm\pi$ have the same color in the figure. Boundaries between white and black colors are s -contours. Points at which different color lines are converged correspond to the vortices of the phase difference. The centers of x -shaped areas are the saddle points of phase difference.

Figure 1 shows the dependence of the dispersion of the phase difference σ_{Δ}^2 of linearly polarized orthogonal components on the ratio l_V of the space between adjacent component vortices of the same sign to the correlation length. Figure 2 illustrates the maps of phase difference for the various primary phase differences $\Delta\Phi_0$ (0 and $\pi/2$). Let us note that the behavior of phase difference does not depend on the primary phase difference of orthogonal components, because the phase differences in both cases differ in the constant value. As a consequence, only the change of the shapes, dimensions and locations of s -contours is observed. At the same time the positions of the saddle points and vortices of phase difference are stationary. It can be seen that s -contours have smaller dimensions and they are practically all closed in the area of figure in the case where primary phase difference equals half the $\pm\pi$.

The results of computer simulation of the parameters of a vector field for different correlation coefficients of the orthogonal components (different levels of the field integral depolarization) are presented in Figs. 3 and 4. A circular primary polarization of the vector field was chosen. In this case, the areas with considerable polarization changes coincide with the areas bounded by s -contours [13].

There is a slight difference in the intensity distributions of the fields (see Fig. 3). As can be seen from Fig. 4, the dimension of s -contours and averaged space between

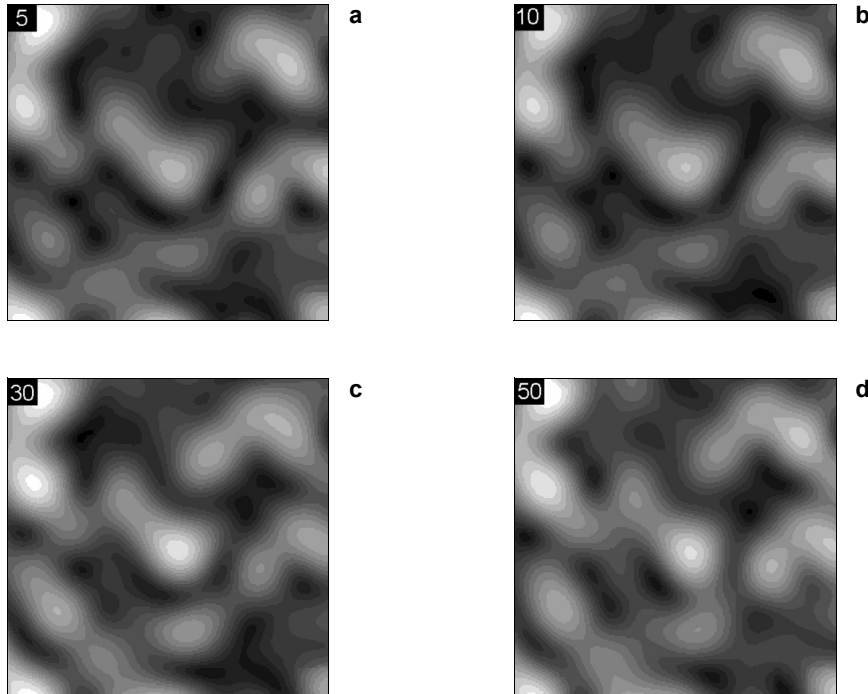

Fig. 3. Intensity distributions of heterogeneously polarized fields (computer simulation). Intensity distributions for 5% (a), 10% (b), 30% (c), 50% (d) depolarization of the field (correlation coefficients of orthogonal linearly polarized components are 0.95, 0.9, 0.7, 0.5, correspondingly).

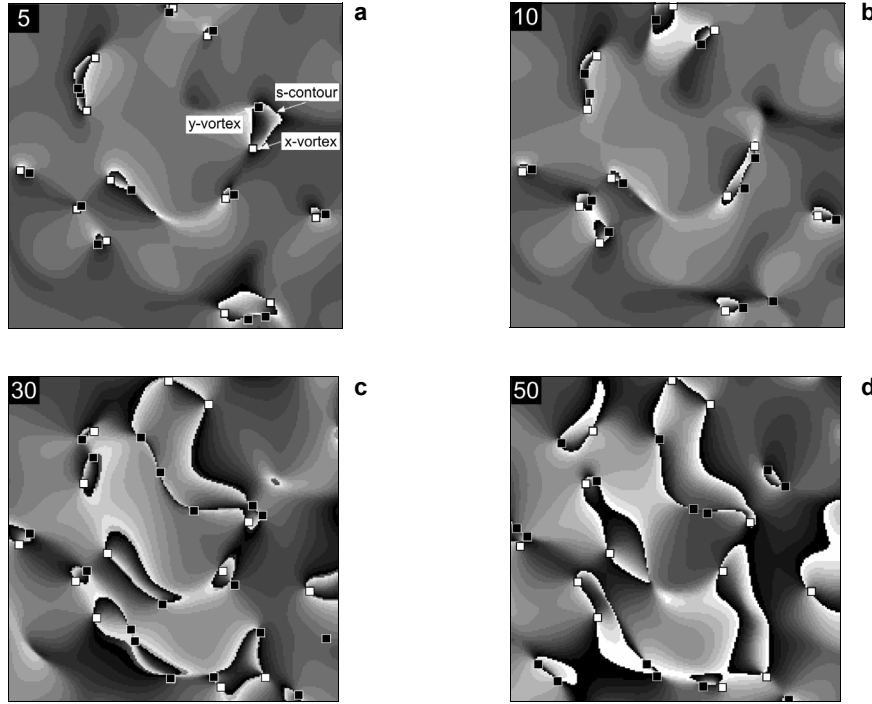

Fig. 4. Maps of the phase difference between the orthogonal linearly polarized components (computer simulation). Phase difference between the components calculated for 5% (a), 10% (b), 30% (c), 50% (d) depolarization of the field (correlation coefficients of orthogonal components are 0.95, 0.9, 0.7, 0.5, correspondingly); \square – x -component vortices, \blacksquare – y -component vortices.

the nearest adjacent component vortices of the same sign increase if the integral depolarization increases. The s -contours are small (relative to the average speckle dimension) simply connected areas of one kind (right-hand or left-hand) polarization, when component correlation coefficient is greater than 0.5. These zones are concentrated close to the component vortices. The dimension of s -contours significantly increases and location of areas with considerable polarization changes becomes random for the magnitude of the component correlation coefficient smaller than 0.5.

5. Analysis of polarization parameters of the field decomposed into circularly polarized components

As is well known, the structure of x, y -components of the field depends on the orientation of decomposition basis. In particular, in our case, the binding requirement is the equivalence of the orthogonal component intensities. On the other hand, it is known that the structure of the field orthogonal components does not depend

on the orientation of basis, when the field is represented as a superposition of circularly polarized components. In this case, the component phase difference is directly related to the azimuth of polarization (see, for example, ref. [8]):

$$\alpha = \frac{\Phi_L - \Phi_R}{2} \quad (29)$$

and the saddle points of phase difference are the saddle points of polarization azimuth.

The coherence matrix obtained by decomposition of the field to the circularly polarized components has the form [2]:

$$J_{\text{circular}} = \begin{vmatrix} J_{RR} & J_{RL} \\ J_{LR} & J_{LL} \end{vmatrix} \quad (30)$$

where $J_{RL}(x, y) = A_R A_L \exp(j2\alpha)$, while A_R and A_L are the amplitude modulo of the circularly polarized components. Matrix components are the random spatially distributed values. In this decomposition basis localization of the phase difference vortices coincides with the positions of C -points.

The Stokes parameters expressed by the elements of the coherence matrix have the form:

$$\begin{cases} s_0 = J_{LL} + J_{RR} \\ s_1 = J_{RL} + J_{LR} \\ s_2 = \frac{1}{j}(J_{RL} - J_{LR}) \\ s_3 = J_{LL} - J_{RR} \end{cases} \quad (31)$$

The operation similar to algebra to the “linear” basis case leads to the following relations of Stokes parameters:

$$\begin{aligned} \bar{s}_0 &= \bar{I}_{LL} + \bar{I}_{RR} \\ \bar{s}_1 &= 2\sqrt{\bar{I}_{RR}\bar{I}_{LL}} \cos(2\alpha_0) \exp(-2\sigma_\alpha^2) \\ \bar{s}_2 &= 2\sqrt{\bar{I}_{RR}\bar{I}_{LL}} \sin(2\alpha_0) \exp(-2\sigma_\alpha^2) \\ \bar{s}_3 &= \bar{I}_{LL} - \bar{I}_{RR} \end{aligned} \quad (32)$$

where \bar{I}_{LL} , \bar{I}_{RR} – averaged intensities of the left- and right-polarized components, correspondingly, α_0 – primary polarization azimuth, σ_α^2 – azimuth dispersion at saddle points of polarization azimuth.

As for the linear decomposition basis, for the circular one the inequality follows:

$$\bar{s}_0^2 \geq \bar{s}_1^2 + \bar{s}_2^2 + \bar{s}_3^2 \quad (33)$$

The so-called “integral depolarization” is observed. The equality in (33) is fulfilled for $\sigma_A^2 = 0$ in the case of completely homogeneously polarized field. It is seen from relation (32) (which is similar to (23)) that the average Stokes parameters can be defined on the basis of the measurement results of azimuth dispersion at its saddle points. Oppositely, the azimuth dispersion may be obtained by simple calculations using the measured Stokes parameters. Note that the dispersion of polarization azimuth may also be represented as a function of space between the nearest adjacent component vortices of the same sign l_{vor} .

6. Comparison of experimental results and data of computer simulation

The Stokes parameters, the averaged space between the nearest vortices l_{vor} and correlation length l_{cor} were obtained both by the computer simulation and experimental testing. Thin polymer films were chosen in such a manner that the field depolarization behind them practically coincided with the depolarization level, which were used in the computer simulation. Experimental testing is carried out in the arrangement presented in Fig. 5. Circularly polarized beam is directed to the Mach–Zander interferometer. A single scattering object (thin polymer film) is put in one of the interferometer arms. Polymer film is placed in the focus of the objective 10. This location of scattering object provides formation of the “far” field just behind the

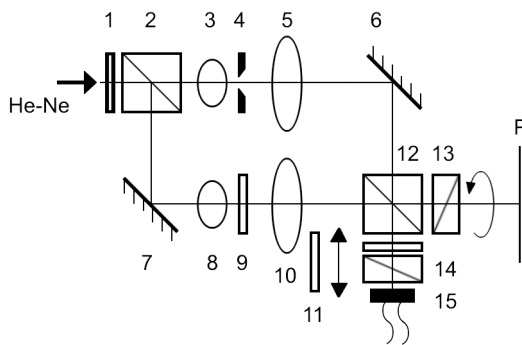

Fig. 5. Experimental arrangement; 1 and 11 – $\lambda/4$ plates, 2 and 12 – beam-splitters, 3–5 – collimator, 6 and 7 – mirrors, 8 – microobjective, 9 – object, 10 – objective, 13 – analyzer, 14 and 15 – Stokes polarimeter.

objective 10. The Stokes polarimeter is put in the output of the interferometer for measuring the averaged Stokes parameters of the beam. Circularly polarized reference beam and polarizer 13 allow us to measure the positions and the signs of component vortices by a method described in [17]. Thus, it becomes possible to simultaneously measure the averaged polarization parameters and the obtain arbitrary linear

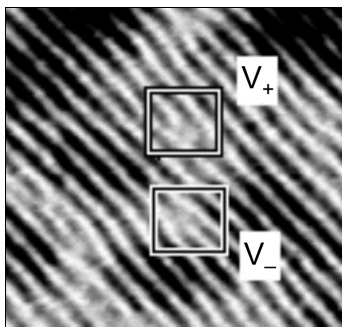

Fig. 6. Example of the interference pattern of some area of the field, where V_+ and V_- are the component vortices of different signs indicated by the opposite directed interference forks.

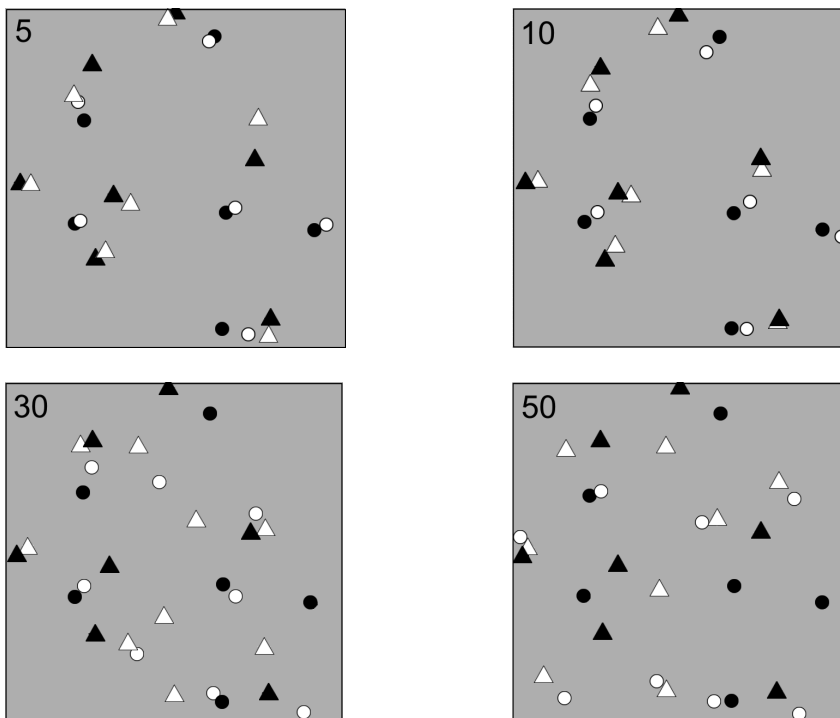

Fig. 7. Location of vortices (computer simulation), which are associated with orthogonal linearly polarized components for different levels of field “depolarization”. The numbers in the left upper corners of each figure correspond to the level of integral depolarization; positions of orthogonal component vortices: ○, ● – positive vortices, △, ▲ – negative vortices.

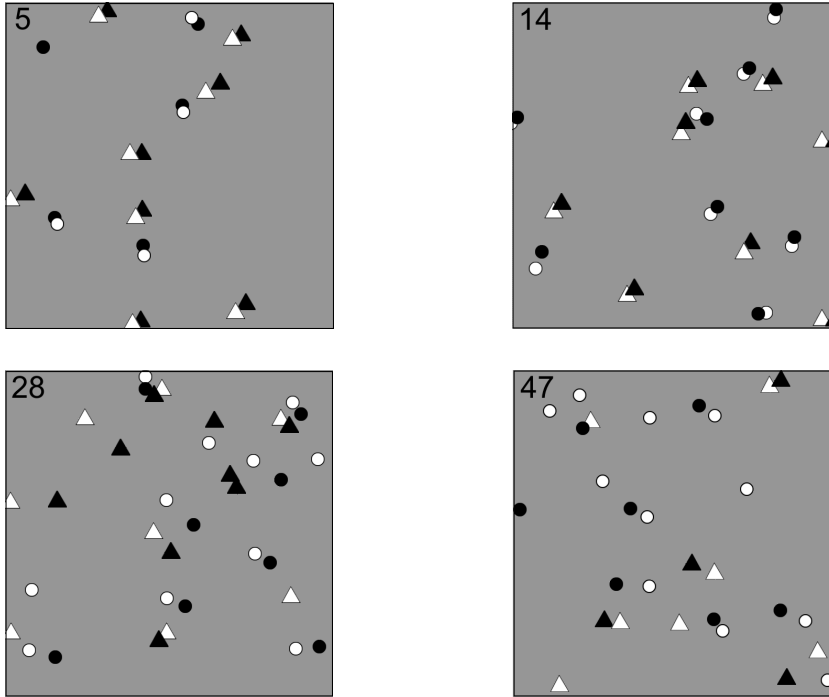

Fig. 8. Location of vortices (experiment), which are associated with orthogonal linearly polarized components for different levels of field “depolarization” obtained by experimental testing. The numbers in the left upper corners of each figure correspond to the level of integral depolarization; positions of orthogonal component vortices: ○, ● – positive vortices, △, ▲ – negative vortices.

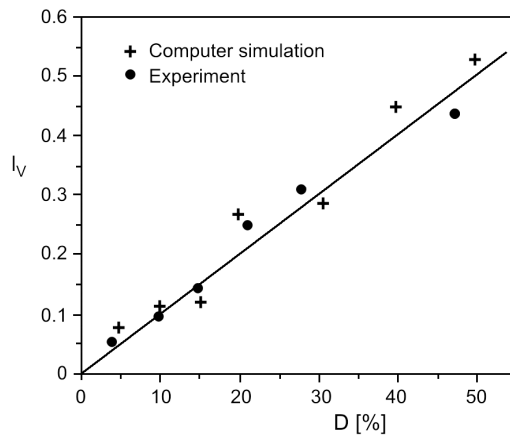

Fig. 9. Relationship of the depolarization level and the ratio of the space between vortices to correlation length; ● – experimental results, + – results of computer simulation.

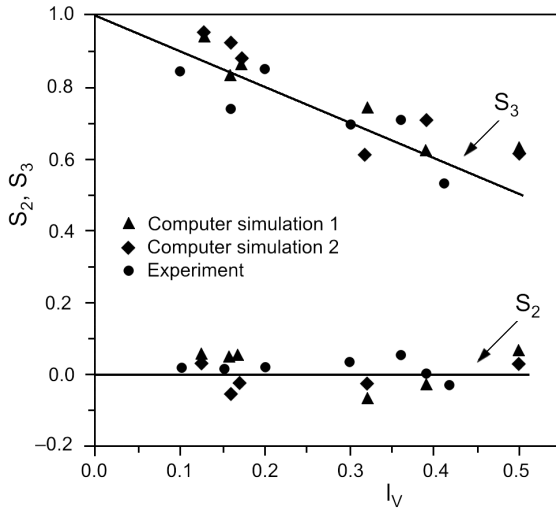

Fig. 10. Dependence of Stokes parameters s_2 and s_3 on the ratio of the space between vortices of the same sign, which are associated with linearly polarized orthogonal components to the correlation length; ● – experimental results, ▲ – results of computer simulation (results obtained on the basis of Eq. (23)), ◆ – results of computer simulation (direct averaging of the local Stokes parameters).

polarized projection of vector field, as well as to determine the location and the signs of projection vortices.

Component vortices of different signs (see Fig. 6) may be identified from the corresponding interference pattern as the opposite directed interference forks [20]. Sets of networks with component zeros were obtained for different objects, which corresponded to the different levels of integral depolarization, and average spaces between the component vortices of the same sign were calculated.

Figures 7 and 8 represent the results of computer simulation and experimental results for different levels of depolarization.

Figures 9 and 10 illustrate the comparison between these results. Figure 9 represents the relationship between the depolarization level and the space between vortices. The dependence of Stokes parameters s_2 and s_3 on the space between vortices of the same signs, associated with the orthogonal components is illustrated in Fig. 10.

It can be seen that these dependences are practically linear. A good correlation between the results obtained by computer simulation and experimental investigation is observed.

7. Conclusions

As a result of our research it has been established, that the characteristics of polarization singularity, systems of special points (vortices of phase difference, C-points, saddle

points of phase difference and polarization azimuth) define not only the qualitative behavior of the vector field at each of its points but also are unambiguously connected with its average polarization characteristics.

Dispersion of phase difference between the orthogonal components, which corresponds to the different levels of the integral depolarization of vector field, is a function of the average space between nearest adjacent component vortices of the same sign, which are associated with different linearly-polarized orthogonal components. Finally, averaged Stokes parameters, dispersion of the polarization azimuth may be obtained by measuring the ratio of such average space to correlation length.

The dimension of the area with considerable polarization changes is defined only by the level of integral depolarization. While the dimension and localization of s -contours for the level of depolarization less than 50% depends on the primary phase difference. The dimension of s -contours is minimal if the primary phase difference is equal to $|\pi/2|$. For the level of depolarization over 50% the fine structure of the field becomes similar to the structure of completely depolarized field and does not depend on the primary phase difference between orthogonal components.

References

- [1] BORN M., WOLF E., *Principles of Optics*, 6th Edition, Pergamon Press, Oxford 1980.
- [2] AZZAM R.M.A., BASHRA N.M., *Ellipsometry and Polarized Light*, North-Holland, Amsterdam, New York 1977.
- [3] ELLIS J., DOGARIU A., *Complex degree of mutual polarization*, Optics Letters **29**(6), 2004, pp. 536–8.
- [4] FREUND I., *Polarization flowers*, Optics Communications **199**(1–4), 2001, pp. 47–63.
- [5] VAN DE HULST H.C., *Light Scattering by Small Particles*, Wiley, New York 1957.
- [6] COZANNET A., FLEVRET J., MAITRE H., ROUSSEAU M., *Optique et telecommunication transmission et traitements*, Eyrolles, Paris 1981.
- [7] MAX J., *Methodes et techniques de traitement du signal et applications aux mesures physiques*, Vol. 2, 3rd Edition, Masson, Paris 1981.
- [8] NYE J.F., *Natural Focusing and Fine Structure of Light*, Institute of Physics Publishing, Bristol, Philadelphia 1999.
- [9] HAJNAL J.V., *Singularities in the transverse fields of electromagnetic waves. I. Theory*, Proceedings of the Royal Society of London, Series A: Mathematical and Physical Sciences **414**(1847), 1987, pp. 433–46.
- [10] NYE J.F., HAJNAL J.V., *The wave structure of monochromatic electromagnetic radiation*, Proceedings of the Royal Society of London, Series A: Mathematical and Physical Sciences **409**(1836), 1987, pp. 21–36.
- [11] ANGELSKY O., BESAHA R., MOKHUN A., MOKHUN I., SOPIN M., SOSKIN M., VASNETSOV M., *Singularities in vectorial fields*, Proceedings of the SPIE **3904**, 1999, pp. 40–55.
- [12] ANGELSKY O., BESAHA R., MOKHUN I., SOPIN M., *Singularities in vector fields*, Proceedings of Chernivtsi University **57**, Physics 1999, pp. 88–99 (in Ukrainian).
- [13] ANGELSKY O., MOKHUN A., MOKHUN I., SOSKIN M., *The relationship between topological characteristics of component vortices and polarization singularities*, Optics Communications **207**(1–6), 2002, pp. 57–65.

- [14] NYE J.F., *Polarization effects in the diffraction of electromagnetic waves: the role of disclinations*, Proceedings of the Royal Society of London, Series A: Mathematical and Physical Sciences **387**(1792), 1983, pp. 105–32.
- [15] FREUND I., SOSKIN M., MOKHUN A., *Elliptic critical points in paraxial optical fields*, Optics Communications **208**(4–6), 2002, pp. 223–53.
- [16] MOKHUN A., SOSKIN M., *Interrelations of fine structure of the vector field and its averaged polarization characteristics*, Proceedings of the SPIE **4607**, 2002, pp. 47–53.
- [17] ANGELSKY O., MOKHUN A., MOKHUN I., SOSKIN M., *Interferometric methods in diagnostics of polarization singularities*, Physical Review E: Statistical, Nonlinear, and Soft Matter Physics **65**(3), 2002, pp. 036602/1–5.
- [18] GOODMAN J.W., *Statistical Optics*, Wiley, New York 1985.
- [19] NIETO-VESPERINAS M., *Scattering and Diffraction in Physical Optics*, Wiley, New York 1981.
- [20] BARANOVA N.B., MAMAYEV A.V., PILIPETSKY N.F., SHKUNOV V.V., ZELDOVICH B.YA., *Wavefront dislocations: topological limitations for adaptive systems with phase conjugation*, Journal of the Optical Society of America A **73**(5), 1983, pp. 525–8.

*Received September 19, 2005
in revised form January 13, 2005*