

Beata Ludwiczak

DESIGN ENGLISH

an English coursebook for students
of Interior Architecture
and Industrial Design



This project was completed with the support granted by Iceland, Liechtenstein and Norway by means of co-financing from the European Economic Area Financial Mechanism and the Norwegian Financial Mechanism as part of the Scholarship and Training Fund.

'Design English' is a coursebook of English for Special Purposes for students of interior architecture and industrial design. It is intended to teach the professional language that is necessary to study and/or work in an English-speaking environment. The book is complemented with expressions connected with studying at a higher education institution and looking for a job in English (writing a CV, reading job advertisements, attending an interview, etc.)

The minimal level of English that is required to use the book is Intermediate (B1). However, the structure has been designed to accommodate groups of diverse abilities. The core part of each unit is not very demanding as far as the general English is concerned. For the more advanced students, the Extension part offers the possibility of indulging in the pleasures of reading the authentic unabbreviated language of Shakespeare and Steinbeck, and can be treated as optional. The Revision part takes the students back to the vocabulary of the previous unit, allowing them to revise, but also broaden, the knowledge acquired in the class.

The invaluable component of the coursebook is the DVD, which features short films illustrating the topics covered by the book. The fourth part of each unit comprises exercises which facilitate and check the understanding of each film. Since many foreign language courses at higher education institutions offer just one meeting in a week, the DVD will provide the student a unique opportunity of broadening the exposure to English outside class. Thus it is intended as a self-study tool. One of the benefits of using it is practicing the correct pronunciation, that is why there are also audio exercises, referring to each unit.

The coursebook is not intended to teach interior design or industrial design as a profession. While collecting materials for the publication, the author found it difficult to decide between American and British English. The sources come from both areas, which is reflected, among others, in different spelling and pronunciation of the same words. However, in the mobile world of today it is impossible to foresee the destinations of the young people's travels, so on the one hand they have to get used to the wonderful variety of this language, and on the other – be ready to enlarge the scope of useful words and expression throughout their lives.

The book would not have been possible without the grant from the Scholarship and Training Fund. The Rector of the Academy of Art and Design in Wrocław, prof. Jacek Szewczyk, supported the project financially, too. I am grateful for this support, and also for the help that I received from the colleagues, tutors in the Academy, my students and companies which permitted us to use their interiors in the films. Stanislaw Sasak, the main coordinator of the DVD production, has proved to be a professional and reliable partner anyone could wish for. Last but not least, I would like to thank my family for their patience and understanding in the last three years.

Beata Ludwiczak

Producenci chcieliby podziękować właścicielom firm i kadrze kierowniczej za zgodę na wykorzystanie ich wnętrz i wyposażenia na płycie DVD.

The producers would like to thank the owners of the companies and managerial staff for the permission to utilize their interiors and furnishings in the DVD project.



Wydawca/Publisher: Akademia Sztuk Pięknych im. E. Gepperta we Wrocławiu/The Eugeniusz Geppert Academy of Art and Design in Wrocław
Pl. Polski 3/4, tel. +48 71 343 80 31, Fax +48 71 343 15 58, www.asp.wroc.pl, mail: info@asp.wroc.pl

Tekst/Text: Beata Ludwiczak | Redakcja/Editing: Beata Ludwiczak | Korekta językowa/Proof Reading: Christopher Nowicki, Beata Ludwiczak

Projekt graficzny, przygotowanie do druku/Graphic layout and pre-press: Jacek Kujda | Rysunki/Drawings: Grzegorz Rozwadowski

Wizualizacje/Renderings: Katarzyna Cichońska, s./p. 97; Joanna Nowakowska s./p. 96 | Konsultacje/Consultations: Eric Hon, Christopher Nowicki, Roman Uss, Jan Kukuła

Druk i oprawa/Print & binding: Masterprint Sp. z o.o. Żerniki Wrocławskie, ul. Wrocławska 16, 55-010 Święta Katarzyna | Nakład/Circulation: 1000 egz./copies

Copyright by Akademia Sztuk Pięknych im. E. Gepperta we Wrocławiu | Wrocław 2011 | ISBN 978-83-60520-38-3



UNIT 1 →	THE ACADEMY OF ART AND DESIGN	4—7
UNIT 2 →	FURNITURE	8—11
UNIT 3 →	LIGHTING	12—15
UNIT 4 →	PAINTS AND COLOURS	16—19
UNIT 5 →	ARCHITECTURAL DETAILS AND TRIM	20—23
UNIT 6 →	FLOORING	24—27
UNIT 7 →	WINDOWS AND DOORS	28—31
UNIT 8 →	KITCHENS AND BATHROOMS	32—35
UNIT 9 →	DESIGNS OF INTERIORS	36—39
UNIT 10 →	DESIGN INTRODUCTION	40—43
UNIT 11 →	STAGES OF DESIGN	44—49
UNIT 12 →	DRAWING SKILLS	50—53
UNIT 13 →	PERSPECTIVE AND PRESENTATION TECHNIQUES	54—57
UNIT 14 →	ELEMENTS OF TECHNICAL DRAWING	58—61
UNIT 15 →	METALS	62—65
UNIT 16 →	PLASTICS AND RAPID PROTOTYPING	66—69
UNIT 17 →	CASTING TECHNIQUES AND 3-D PRINTING	70—73
UNIT 18 →	FABRICATION TECHNIQUES	74—77
UNIT 19 →	MACHINING TECHNIQUES PLASTIC FORMING AND FINISHING PROCESSES	78—81
UNIT 20 →	DESIGNS OF PRODUCTS	82—85
ADDITIONAL MATERIAL →		86—87
KEY →		88—89
AUDIO EXERCISES - SCRIPT →		90—95
COLOUR PICTURES → UNIT 9 →		96—97
COLOUR PICTURES → UNIT 20 →		98—99
BIBLIOGRAPHY →		100
NOTES →		100

I. Answer the following questions:

1. Are you a student of an artistic higher education institution? What is its English name?
2. What do you know about the authorities of the institution (the most important persons)?
Write the names of their functions. Do you know which of them are elective and which are long-term?
Who is in office now – can you say their first and last names?
3. The E. Geppert Academy of Art and Design in Wrocław is divided into four main units.
What is the name of the head of each unit?

II. Read the short profile and complete it with the following words:

awards, exchange, Faculties, part-time, festivals, majors, graduates, solo.

The Academy of Art and Design in Wrocław provides instruction at four _____ : Painting and Sculpture, Ceramics and Glass, Graphics and Media Art, and Interior Architecture and Design, to about 1 000 students.

The students can select one of the six _____ : painting, sculpture, graphics, design, interior architecture and media art at the BFA and MFA courses, full-time and _____.

This higher education institution can boast remarkable artistic achievements, and its professors and _____ win _____ and honorary mentions in a lot of _____ and joint exhibitions and competitions in Poland and abroad.

The Academy of Art and Design is actively developing its international relations. It facilitates the _____ of students and tutors with more than 40 partners within the EU Erasmus Programme, and also with non-European partners on the basis of bilateral agreements (USA, Japan, Israel, Canada, Korea).

There are joint exhibitions and workshops organized, students and professors participate in national and international open days and _____.

The Academy continuously strives to broaden its didactic and artistic offerings. This we hope will benefit not only our Academy but also the City of Wrocław and Poland. (ac. year 2011)

**III. Listen to the text about the Department of Interior Design and fill in the blanks.**

The Department of Interior Design was established in _____. Currently the instruction at the department is based on four _____ modules – major instruction, general art instruction, complementary instruction and the humanities.

The studies are run in a two-degree system: _____ of Fine Arts and _____ of Fine Arts. The BFA course lasts six semesters (_____ years) and the MFA course lasts four semesters (_____ years).

The major course offered to students on the first and second year of studies is aimed at teaching basic rules of the _____ and three-dimensional composition as well as shaping materials. Students of the first years learn the fundamentals of programming, constructing and shaping the form of the furniture, _____ space and the interior.

The students receive theoretical knowledge connected with the fundamentals of interior design, exhibition design and _____ graphics. Volunteering students can take up the elective _____ design and costume design courses.

After the second year the interior design students have the possibility of selecting one of the four diploma-awarding _____. These are three studios of Interior Design and one studio of Furniture Design.

The students complete two courses of studies by realizing the diploma work. It consists of: the diploma project, a _____ connected with the project theme and the fine arts annexe, realized in a selected general fine arts studio.

The graduates can find employment in architectural firms, interior design companies, _____ companies as well as furniture manufacturers as furniture designers. They can work freelance in the field of interior, _____, exhibition or stage design as well. (ac. year 2011)

◀ audio ▶

IV. Listen to the text about the Department of Design and make notes in order to answer the following questions:

1. What year was the Department of Design opened?
2. Do students learn to design workplaces?
3. Tick the courses that you hear:

- stage design
- preliminary design of industrial forms
- graphic design with lettering
- flat and spatial composition

4. What studios of general fine art education are mentioned?
5. What MFA studios are there?
6. What forms of instruction are mentioned?
7. What does the studio organize as additional form of instruction?
8. What are the components of the MFA diploma?

V. What skills do designers require? Finish the sentence and then play the chain game:

A good designer has to be _____.

VI. Freelance or practice? Discuss in pairs which option is better.

VII. Now read the points below and write a [+] next to an advantage and a [-] next to a disadvantage:

Going freelance	Setting up a practice
– Low overhead costs; can work from home.	– You will immediately appear more professional.
– Home – and work-life may clash in terms of space and time.	– Your clients can visit you in your office.
– Less regular working hours – sometimes work may be scarce, at other times you may be very busy.	– You could be able to charge more for your work.
– Work, samples and brochures will take up space at home, and may cause a mess.	– Accounts are more complicated than being a freelancer, and accountants will charge you more.
– You can deduct a lot of costs for taxes: for example, your work phone bill.	– It is easier to get trade accounts with suppliers.
– You can take on as much work as you wish.	– You can open a business bank account with overdraft facilities.
– You may struggle to appear as professional as contemporaries who are employed or running their own practice.	– Greater overhead costs involved in running an office.
– You can use your own bank account and avoid business banking charges.	– You can more easily keep to regular office hours, and leave work behind you at the end of the day.
	– You can work with a business partner to share decision-making and stress.

C.V. AND COVERING LETTER

You are going to read a text about writing a c.v. and covering letter.

Match the subtitles below to the paragraphs of the text:

Being selective, Preparation, Covering letter, Presentation, Creating your c.v., Format.

1. _____

Before you begin writing your c.v., take some time to clarify your personal goals and objectives. This will help you focus your application by making it relevant and appropriate for your desired outcome. Consider your career direction in which you wish to move by targeting specific employment opportunities and employers. Phone the organizations you are interested in and find out their recruitment requirements. It is important that your skills and abilities match the job specification you are targeting. Put yourself to the test and consider the reasons why an employer should choose you.

2. _____

Your objective when writing your c.v. is to secure your first steps towards getting an interview. This means highlighting your strengths and playing down your weaknesses. When writing, avoid negative or passive phrases, such as 'some experience' or 'helped and assisted'. Use active words such as 'developed', 'researched', 'supervised', or 'organized'.

3. _____

Remember to provide the required information, not your life story to date. List your most recent and relevant experience. Being selective and concise results in a c.v. that is professional and effective. Highlight important information by editing irrelevancies. Tailor your c.v. for different applications by adapting the information to suit different job specifications. Don't be afraid to blow your own trumpet – employers are reassured by confident and strong applicants. Above all, check your c.v. carefully for spelling mistakes and grammatical errors.

4. _____

There are different types of c.v. and therefore different ways of compiling them. The most traditional one is the chronological c.v., which can be adapted to your own style. This format lists personal information, education, qualifications, skills, achievements and interests. A skills-based c.v. is a more effective format for life and work experience. It categorizes and divides important skills into broad areas by identifying the attributes such skills require. Examples include technical skills, managerial skills and time management skills. These target the requirements of prospective employers.

5. _____

Your c.v. should be of the highest aesthetic standard. Research has shown that c.v. communication is 80 per cent presentation and 20 per cent content. This suggests, correctly, that the market will be competitive, and a prospective employer will have many professional applications to choose from. From the employer's point of view, the initial process is therefore one of elimination. A c.v. that is badly designed will be easy to disregard. Creating a visual impact is a must. For text, choose a font that is both legible and attractive. Highlight important phrases to bring attention to critical skills and achievements. Include visuals where possible – even a personal logo or letterhead can make a document visually stimulating (...). Every detail, right down to the quality of paper you use and your print quality, will be noticed. Remember that a c.v. is a snapshot of you, so present yourself well.

6. _____

Every c.v. that is sent requires a covering letter. A letter is a personal communication, so avoid using 'Dear Sir or Madam'. It only takes a phone call to find out the relevant contact name. In the opening paragraph, introduce what you are applying for as well as providing your reasons for wanting to apply. If you are responding to an advert, you should cite the job vacancy and the place you saw it advertised. If you are writing a speculative letter, you should introduce yourself and identify your current professional position or the relevant stage of your study. Use the rest of the letter to demonstrate background research on the organization and its work. Show that you are eager and interested by providing evidence of specific personal achievements you feel would suit the organization.



The exercises must be done on the basis of the film dialogues.

I. Watch the film and then select the correct answer:

1. The girl is:

- a) an exchange student
- b) an undergraduate student
- c) a graduate student

2. Both students

- a) study interior design
- b) study industrial design
- c) are at the same Faculty

3. The student from South Africa

- a) wants to meet her tutors
- b) really likes her tutors
- c) has a long way to meet her tutors

II. Listen to the film dialogue carefully and circle the words that you hear:

full-time
part-time
Master of Fine Arts
Bachelor of Fine Arts
postgraduate
supervision
competition
joint shows
degree shows
art supply store
sculpture studio
painting studio
lectures
classrooms
critiques
exhibitions
seminars
classes
tutorials
workshops

III. Decide if the following sentences are true or false:

1. The male student is doing his last year at the Academy.
2. He has already had a few solo exhibitions.
3. There is a glass door leading to the printing studio.
4. The printing studio is very busy especially when the semester ends.
5. Lectures are the most common form of instruction in an art school.

I. Answer the following questions:

1. Think of your home. How many items of furniture can you name?
2. Do you know any famous designer's piece of furniture? Can you sketch it? Tell your partner about it.
3. Read the text below. Can you give examples of the types of furniture mentioned?

Furniture is the collective term for the movable objects which may **support the human body (...), provide storage, or hold objects on horizontal surfaces above the ground.** Storage furniture (which often makes use of doors, drawers, and shelves) is used to hold or contain smaller objects such as clothes, tools, books, and household goods.

Furniture can be a product of artistic design and is considered a form of decorative art. In addition to furniture's functional role, it can **serve a symbolic or religious purpose.** Domestic furniture works to create, together with furnishings such as clocks and lighting, comfortable and convenient interior spaces.



**II. Group the following nouns into the five categories.
There are some definitions on page 86 to help you.**

Storage	Surface	Sets	Seating	Other
⋮		⋮	⋮	⋮

Stool, street furniture, coffee table, desk, bookcase, couch, end table, stacking chair, footstool, dresser, bedroom set, bed, built-in furniture, love seat, rocking chair, sectional, sideboard, ottoman, draw table, china cabinet, park furniture, settee, dining set, hall tree, armchair, armoire, door furniture, bench, filing cabinet, table, vanity set, headboard, bunk bed, chair, wardrobe, cupboard, chest, four-poster (bed), folding chair, bean bag, sofa, cabinet, closet, upholstered chair, sofa bed.

III. Read the text about leather furniture and choose the correct word:

Some *low-cost/high-cost* leather furniture uses *genuine/synthetic* leather for cushions and backrests while *genuine/synthetic* leather is used in *high-friction/low-friction* areas such as armrests and at the base of the piece. This *increases/decreases* the life of the piece and reduces maintenance. Leather will *contract/expand* with heat, and *contract/expand* with moisture. Care should be taken to prevent excessive sunlight from fading the furnishing.

**IV. Leather furniture can be made from: *synthetic leather, protection leather and genuine leather.*
Match the types with the descriptions.**

1. _____ comes in various processed forms and has a 'soft hand'. Naturally dyed leather tends to show imperfections. It ages the best because there is no top coat to crack with age.

2. _____ gets dyed first and then a protective layer is absorbed into the surface to prevent staining, scuffing and scarring. It has a 'semi-soft hand'.
3. _____ is very durable, won't stain easily, does not come from animals, but does not have a 'soft hand'. It is generally colder to the touch than genuine leather and will also heat up in the sunlight. It is nonporous, so it doesn't breathe well.

V. Find in the word snake 9 names of other materials that furniture can be made from:

veneersolidwoodplywoodhardboardcanecardboardlaminatedboardbamboowicker

◀ audio ▶

VI. Match the pictures of the famous designers' chairs with their descriptions. Then cover the texts and try to describe the chairs yourself:

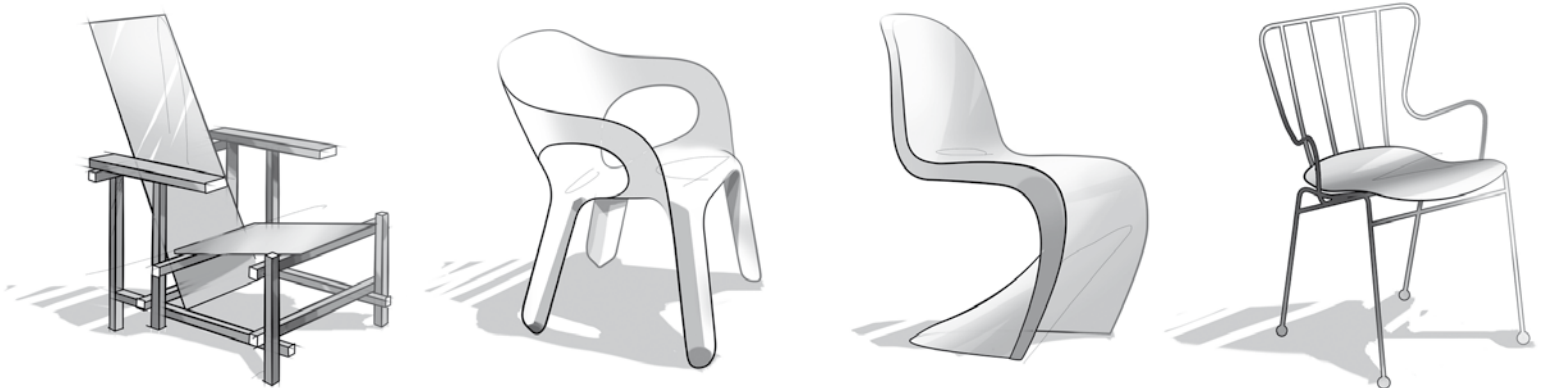

1. **Easy Chair** – light, stackable, easy-to-clean form of seating. Yet the generous, almost exaggerated form and bold colours hint at the designer's raunchy sense of humour.
2. **Panton Chair** – sexy, sleek and a technical first – as the first cantilevered chair to be made from a single piece of plastic.
3. **Antelope** – light, compact, and made with minimum material. Its jaunty curves, spindly legs and comical ball feet evoked the growing optimism of the British in the 1950s.
4. **Red/Blue Chair** – an abstract composition of surfaces and lines in space, this chair is a three-dimensional vision of the minimalist paintings of Piet Mondrian. It is made from standard lengths of wood, which require little skill to construct.

VII. Now make a floor plan of your room, draw in outlines of articles of furniture and other furnishings. Do not show the drawing to you partner! Describe the room to your partner so that he/she is able to draw your room on the basis of what you say.

Match the nouns with appropriate verbs. You can use each of them once.

gain	freelance
carry out	materials
realize	a project
source	experience
receive	a brief
work	a studio
take up	a degree

Then write sentences about your first days at the Academy, using the phrases above.

.....

Before reading, check the meaning of the following words: *defunct, pursue.*

Konstantin Grcic was born in 1965 in Munich and now has his studio there. Unusually for an industrial designer, he trained as a craftsman in wood, at the influential but now defunct Parnham College in Dorset (...).

Making his own furniture helped him to understand appropriate materials and methods for industrially manufactured objects, but he has long ceased to make his own designs himself. A typical Grcic design will appear to be simple and straightforward at first glance, but on closer inspection it will reveal nuances and subtleties (...).

In 1990 Konstantin Grcic graduated from the Royal College of Art and for a time he worked in Jasper Morrison's studio. This placed him at the centre of the New Functionalism group of designers (...).

The following year saw Grcic return to Munich to set up on his own. His early furniture tended to be made in timber and metal, such as the Refolo all-metal trolley he designed for Driade to house computers, stereos or televisions (1995). The design was strictly functional, but escaped the aesthetic of the office by featuring strong colours for the different clip-on elements. Its flexibility and suitability to the home-office reflected trends in domestic design at the time. Humble plastic products such as laundry baskets and waste-paper bins for the German manufacturer Authentics opened the mass-market to his designs.

Grcic developed the Chair One range (2001-4) with Magis in Italy. Chair One was a linear triangular metal grid, cast in aluminium (...).

His Miura stool for Plank in 2005 was even simpler and strikingly sculptural. He's a designer who's not out to change the world, yet he creates objects that suggest types of behaviour, and pursues demanding, neutral, well-thought-out projects that are bound to have a lasting effect.

Answer the questions:

1. What is K. Grcic's basic training?
2. Does he execute his projects himself?
3. What is his typical design like?
4. What were his favourite materials in the early years?
5. Are some of his designs mass-produced?

Write a CV of Konstantin Grcic.



The exercises must be done on the basis of the film dialogues.

I. Watch the film and then select the correct answer:

1. The furniture on display

- a) is designed in oriental style
- b) is designed in the Polish traditional style
- c) is carefully prepared

2. The dining set is:

- a) in the corner of the room
- b) by the door to the bedroom
- c) in the centre of the room

3. Tomasz prefers:

- a) to study in the bedroom
- b) not to see the next room
- c) upholstered headboards

II. Listen to the film dialogue carefully and circle the words that you hear:

beanbag chair
 reclining chair
 cushions
 sleekness
 coziness
 love seat
 settees
 handmade
 carved
 upholstered furniture
 sideboard
 cardboard
 display cabinet
 headboard
 sleep-inducing
 enhancing

III. Decide if the following sentences are true or false:

1. Zoe prefers sofas for two people.
2. The coffee table features drawers and a shelf.
3. Zoe has to research wood furniture.
4. The table and chairs in the dining room are completely different.
5. The mirror reflects the display cabinet.

I. Think of different lighting units that you have in your home and name them.

II. Match the three basic types of lighting with their definitions: *accent, task, ambient*:

- _____ – functional lighting used for a specific purpose
- _____ – highlights an area or furnishing of interest
- _____ – generally warm, low lumen lights that create the mood (also: mood l.)

Can you decide now what is the function of the light units listed by you in ex. I?

III. Rearrange the following words to find 4 types of bulbs:

oglahen, centorflues, indescancent, eld.



IV. Read the information table about **fixed lighting** and complete the text with the following

words: *foot, tables, installation, downward, options, lasting, radiates, shadows.*

Then listen to check your answers.

FIXED LIGHTING

Pros: Focused light, long _____, low maintenance, elegant.

Cons: Most require professional _____ at construction time, inability to alter lighting layout easily.

A. RECESSED LIGHTING

Fixture	About	Pros	Cons
Canister downlights	The lighting fixture is mounted entirely into the ceiling and points _____. Ambient floodlight with soft fall-off.	Low fixture visibility	Uni-directional
Eyeballs	The lighting fixture is mounted into the ceiling and is directional. Downward, spotlight beam with hard edges creating dramatic _____.	Omni-directional	High fixture visibility

B. SURFACE MOUNT/ARCHITECTURAL LIGHTING

Fixture	About	Pros	Cons
Sconce	A small fixture mounted to the wall that _____ light onto the wall and ceiling. Generally used as decorative or accent lighting.	High fixture visibility in decorative style. Can be replaced easily.	Luxury lighting providing little usable light.
Pendant/ chandelier	The base is mounted to the ceiling with the lighting fixture suspended from it. Generally used over _____. Direct lighting with semi-hard shadows.	High fixture visibility. Can be replaced easily. Useful for tasks. Adds to overall brightness of room.	Requires dusting. Hangs from the ceiling, reducing vertical space.
Track lighting	A long track that powers moveable lighting elements. Generally mounted onto the ceiling or wall with various lighting element _____.	Omni-directional used for accent lightings.	High watt consumption
Undermount lighting	A lighting fixture mounted under a counter, cupboard, or at the _____ of a cabinet. Indirect lighting with various dispersions.	Light is focused to area of use.	Does not add to overall brightness of room.

V. Now write the pros and cons of mobile lighting using the expressions from ex. III. (do not repeat the expressions). You can include the sentences referring to the general characteristics of mobile lighting. There are definitions on page 86 to help you.

MOBILE LIGHTING

Pros: Easy to change lighting layout and style.		Cons: More susceptible to dents and scratches. Can be knocked over, creating fire hazard.
Lamp	Pros	Cons
Table lamp		
Desk lamp		
Floor lamp/Torchier		
Freestanding lamp		

VI. Match the descriptions of the lamps with the pictures.

1. Anglepoise lamp is supported and balanced by a sequence of springs which can be moved easily in every direction yet also remain rigid when held in position. The heavy base stabilises the lamp, and the shade concentrates the beam on specific points without causing dazzle. The lamp can be both flexible and stable, like a human arm.

2. Table lamp by Paul Hanningsen is a form of lighting dependent on concentrically arranged layers of shade. He used opaque glass and chromed metal, materials associated with modernist functional design. The shade of this lamp provides diffused light, preventing glare from the lamp.

3. The Akari series uses the traditional materials of the Japanese lantern. The sculptor Noguchi also wanted associations with the moon to give the lamp a symbolic significance. The original version of the lamp has been adapted by mainstream companies to provide an inexpensive light fitting, which can be flat-packed in a concertina action and sold cheaply.

4. As well as designing sophisticated track lighting systems, Ingo Mauer's design team produce lamps which make statements. The natural bird feathers, a popular motif with Post-Modernism, comment on the technical precision of the rest of Bibibibi lamp.

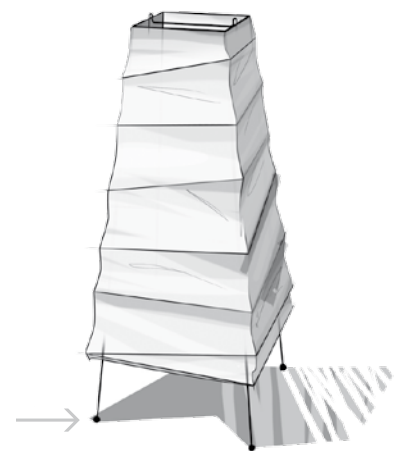
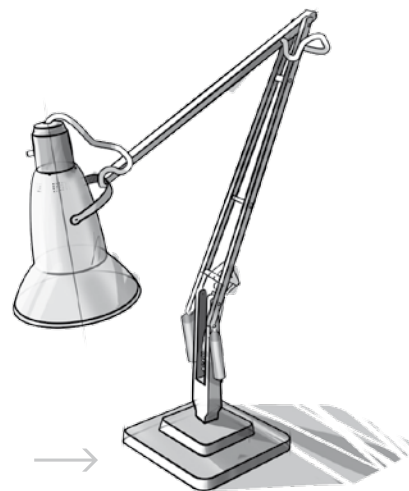
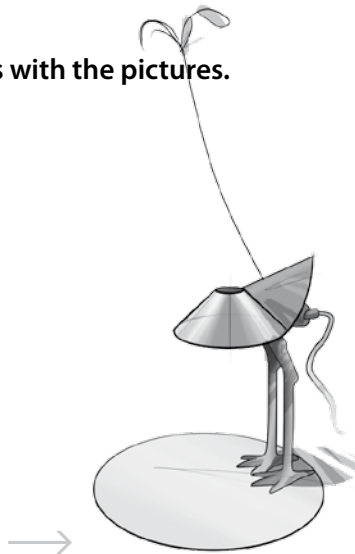

VII. Take a look at two rooms in your house. It would be good to pick one that is generally quite busy – such as a kitchen, and one that is used for relaxation, such as a lounge or a bedroom. How many lighting scenes are available within this space? Is there enough lighting flexibility? Consider the layout of the space and the positioning of the furniture. Draft out a sketch lighting plan and make a presentation to your class.

Read about typological orders of furniture and decide which of the following pieces are examples of each type: *bean bag chair, coffee tables, IKEA writing desk, tea trolley, wall-mounted cabinets, folding chair.*

Ready-to-assemble (RTA) furniture is distributed and sold in an unassembled state and assembled by the consumer. RTA furniture is also known as flat-pack or knock-down furniture – _____.

When **built-in** furniture is carefully integrated with its surrounding space, it can enhance the continuity of architecture. Built-ins require on-site installations and mechanical attachment to a floor, wall, or ceiling – _____.

Most furnishings are **freestanding** but few are designed to be experienced in the round. (e.g. beds or couches are often placed against a wall. Coat racks are typically located in the corner). _____ are designed to be experienced from all directions.

Inflatable furniture is internally 'filled' and externally 'sheathed'. Inflated furnishings are often designed for temporary use and can be made compact for easy storage – _____.

Mechanical joinery can allow furniture to transform into different shapes – _____.

Movement can enhance function. **Movable** furniture utilizes casters to promote functional movement. It is specifically designed to freely roll about in space – _____.

Before reading the text, look up the following words:

evocation, elevate, poltergeist, to sequester, artifact, to appropriate.

One of Jurgen Bey's most famous designs was for the Light Shade shade (1999). Again, an existing object was resurfaced. This time he chose what some might regard as tasteless old table lamps, which he encased in shiny, reflective new polyester foil cylinders. They were made all the more odd because Bey converted them into pendant lamps. When the lamps were switched off they were invisible, but switched on they appeared through the foil like ghostly evocations of themselves, table lamps mysteriously elevating in the control of poltergeists, perhaps. Bey was wrapping up the past, protecting and sequestering the object and all the memories attached to it. By making familiar, discarded objects unfamiliar and strange, he drew our attention to their values. He was not only recycling artefacts but also keeping continuity with the past.

Jurgen Bey, therefore, seems to recycle old furniture and styles to remind us of the value of the past. Does this make him a neo-conservative, looking over his shoulder rather than forward into the future? He appropriates petit bourgeois symbols such as rococo revival tea sets and parlour chairs but with irony, gently mocking our nostalgia for the certain ties of history. His designs are theatrical, camp even, but they speak eloquently. 'Everything has a voice and speaks its own language,' he said. 'And so design is also a language, subject to rules.'

Answer the questions:

1. What objects did Jurgen Bey decide to use for his Light Shade series?
2. What did he wrap them into?
3. What did they become?
4. How did the lamps behave when switched on and off?
5. How did Bey draw our attention to the values of discarded objects?
6. What does it mean that he is a neo-conservative?



The exercises must be done on the basis of the film dialogues.

I. Watch the film and then select the correct answer:

1. At the Product Design Course the students often:

- a) fix lighting units
- b) design different types of lighting
- c) design ambient light

2. Tomasz's friend:

- a) makes lamp bases from ceramic material
- b) makes paper shades by hand
- c) makes floor lamps from polystyrene

3. The floor lamp the students are talking about:

- a) gives mood light
- b) features a dimmer
- c) gives very dim light

II. Listen to the film dialogue carefully and circle the words that you hear:

lighting fixtures
lighting units
track lighting
floodlight
layout
shadows
chandelier
mounted
pendant lamp
diverse
omni-directional
decorative style
polystyrene
brightness
fall-off

III. Decide if the following sentences are true or false:

- 1. The students concentrate on designing shades.
- 2. A chandelier's base is attached to the ceiling.
- 3. A pendant lamp is always made from glass.
- 4. The shop sells lamps made by Tomasz's friend.
- 5. Zoe is going to prepare for her exam.

I. Answer the questions:

1. Can you name reasons for painting a room?
2. When did you last remodel your room?
3. Did you paint it yourself or did you have it painted?

II. How can colour shape and alter space? Complete the sentence below with the following words: *recede, warmer, advance, heavier, cooler, lighter.*

Colour can make objects look _____ or _____, spaces seem _____ or _____, or cause planes to _____ or _____.

III. Most paints are classified according to their vehicles or binders.

Decide which one of the two definitions describes binder and which vehicle.

1. _____ – is the part of a paint that holds the pigment particles together, forms a film and gives certain properties to the paint.
2. _____ – is all of a paint except the pigment; the liquid portion of a paint.

IV. Complete the definitions in the right column with the appropriate word form and match the names of paint ingredients with their definitions: *solvents, alkyds, latex, pigments.*

_____	Oil-modified resins that dry faster and are much harder than ordinary oils. Dry quickly and evenly, are durable for both interior and exterior (apply) _____, are easy to apply and are moderately priced. When compared to latex exterior paints, show (poor) _____ gloss and colour retention and tend to yellow over time.
_____	Synthetic materials that vary in hardness, (flexible) _____ and gloss retention. Advantages include ease of application, (free) _____ from solvent odor, fast drying and recoating, minimal fire hazard, blister and peel (resist) _____ and ease of cleanup (soap and water only).
_____	The minute solid colouring parts of paints. They confer the following properties: hiding power or (opaque) _____, protection, corrosion resistance on iron and steel. Some act as fillers.
_____	Liquids that dissolve the resins or gums or other binder constituents. These liquids are mineral spirits in case of alkyds, water for latex emulsions, alcohol for shellac, lacquer (thin) _____ for lacquers.

**V. Listen to the text about types of coating products and fill in the blanks:**

Enamels are pigmented paints that produce a hard, glossy, durable _____, with the pigments ground finer in order to produce a _____ texture. They come in semi-gloss and gloss, but a flat appearance can be produced by adding a flattening _____. Enamels and other paints should be applied to a properly prepared surface. A glossy surface will not have _____ and should be sanded with _____.

A primer is the first coat applied to the substrate to prepare for subsequent _____ coats. Some primers may serve as sealers which prevent the _____ of paint caused by absorption of the porous materials.

Stains are pigments applied to _____ or sealed wood and may be transparent or _____, depending upon requirements. Stain waxes do the staining and waxing in one process, allowing the natural _____ to show, while providing the natural finish of a wax.

Varnish is a transparent or pigmentless _____ applied to stained or unstained wood. When the surface of a varnish stain is _____, the natural wood colour may show through.

VI. Match the four paint application methods with the pictures: brush, roller, pad, spray gun.

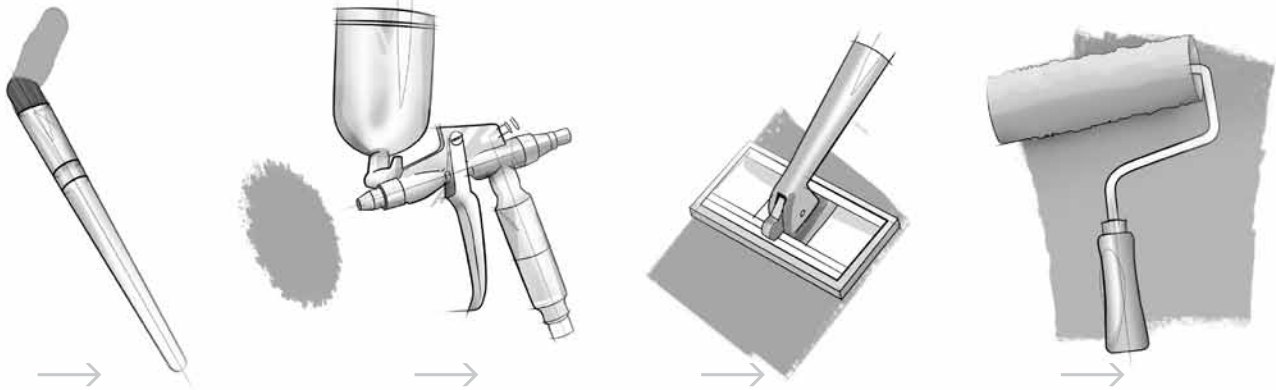

VII. Read the text and fill in the gaps with the following words:

splashing, dents, affect, swatch, dab, cohesion, subtle, aesthetics, space, dry, sample, cleanliness.

Color is a _____ yet fundamental design element. When used properly it changes the room from just a _____ to an experience. Color and harmony enhance the _____ and provide _____ of design.

A new layer of paint over properly treated filler to hide holes and _____ will improve the perception and value of the home. It reinforces _____ and may make the room look more organized. _____ color to an otherwise drab room may give it new-found life.

When comparing paint colors, _____ wet paint on a neutral gray card. After 24 hours, the paint should be completely _____ and ready for comparing to other colors. If comparing to an existing wall or other item, cut off the gray area around the new _____ because it will _____ color judgment. Most paint companies provide a _____ book for cutting samples from.

VIII. Faux painting is an example of decorative painting. It makes the painted surface resemble real material. Match the names of faux paints with the surfaces they imitate:

- | | |
|---------------------|-------------------------|
| 1. marbleizing | a) architectural detail |
| 2. graining | b) stripes |
| 3. trompe l'oeil | c) texture |
| 4. Venetian plaster | d) wood |
| 5. strie | e) marble |

IX. What do you think is the tool for creating two other decorative painting techniques, rag painting and colour wash?

X. Match the important terms connected with colours with their definitions:

analogous colours, complementary colours, value (tone), primary colours, hue, saturation

- | | |
|--|--|
| 1. red, yellow, blue | 4. the quality by which we distinguish lightness or darkness of a colour |
| 2. the quality by which we distinguish one colour from another | 5. colours that are close to each other on the colour wheel |
| 3. the strength or relative purity of a colour | 6. colours that are opposite to each other on the colour wheel |

XI. Below there are adjectives used to describe colours. Divide them into two groups depending on their strength: bold, pastel, deep, pale, vibrant, bright, rich, subtle, vivid, soft, light, muted, subdued.

Below there are tips how to alter the way a room looks with a clever lighting scheme. Write **L** if the room will appear larger, **T** – if the room will appear taller or **C** – if it will appear cosier, next to a sentence.

1. Use wall lamps or wall washers on a large expanse of light coloured ceiling.
2. Hang pendant lamps or chandeliers low.
3. Use uplighters to bounce light onto the ceiling and walls.
4. Don't allow light onto the ceilings.
5. Use several table lamps or desk lamps to create lots of little low pools of light.
6. Use vertical light beams, for example torchiers.
7. Light all four corners of the room.

Before reading, check the meaning of the following words: *launch, crop up, guise*.

New takes on trompe l'oeil mix postmodern humour with technical artistry. [They have] also become a major trendsetter. When as a college leaver Bowness launched the collection of wallpapers in 1999, there was nothing similarly modern available on the market. She was inspired by early scenic French wallpapers, Dutch still-life artists (...) and by the beautiful objects her friends owned that she could neither afford nor had a home for. In addition she wanted to add 'depth' and interest to wallpaper, which at the time was relatively flat and uninteresting.

Now, modern takes on trompe l'oeil are beginning to crop up in interiors collections (...). But rather than mimic the traditional form of the art that in one of its earliest (Renaissance) guises was all about promoting man's skills at mimicking or even surpassing nature, these new practitioners of trickery utilize photographic and specialist graphic and print forms of the genre. 'The new trompe l'oeil is more clever than ever', says Smith, 'because with modern production methods it leaves the viewer not only guessing about the realistic boundaries of objects but also the complexity of their construction. We are no longer dealing with painterly effects but modern technology artistry'.

Answer the questions:

1. What do modern versions of trompe l'oeil combine?
2. What was the inspiration for their revival?
3. How was wallpaper enhanced by trompe l'oeil patterns?
4. Why is the new trompe l'oeil a clever invention?



The exercises must be done on the basis of the film dialogues.

I. Watch the film and then select the correct answer:

1. The most popular paint is:

- a) oil paint
- b) latex paint
- c) acrylic paint

2. The computerized system

- a) makes it possible to see dreams
- b) makes it possible to obtain different shades of paint
- c) makes it possible to see colours in buckets

3. Light colours

- a) give the feeling of height
- b) make the room look larger
- c) make the room look smaller

II. Listen to the film dialogue carefully and circle the words that you hear:

gloss
 eggshell
 translucent
 odourless
 applicaton
 correction
 roller
 sprayer
 trompe l'oeil
 primary colours
 primer
 subsequent coats
 graining
 swatches
 dab
 hue

III. Decide if the following sentences are true or false:

1. Water-based paint is not available in the Centre of Paints.
2. Latex paint is difficult to apply and odourless.
3. A primer is the first coat of paint applied to a surface.
4. Colour looks darker when you just paint a small sample.
5. Horizontal stripes make the room look wider.

I. Answer the questions:

1. What do you understand by 'architectural details'? Can you give examples?
2. Look the word 'trim' up in the dictionary.
3. What do you think are functions of architectural details and trim?

II. Complete the text with the following verbs (sometimes you may have to change their form):
hide, tie, employ, add, improve. Then read the text again and check if it mentions the same functions as you did in ex. 1, 3.

Create distinction in a room and its surrounding space by _____ decorative architectural details. Trim and molding can help _____ the rough edges where window, wall and door corners meet. They can _____ the perception and value of the home if they are carefully planned and not overdone. Trim, molding and accents _____ architectural interest to the home and help _____ patterns in the room to the style of the room.

III. Match the names of the architectural details with the pictures:
dado, medallion, window seat, corbel.

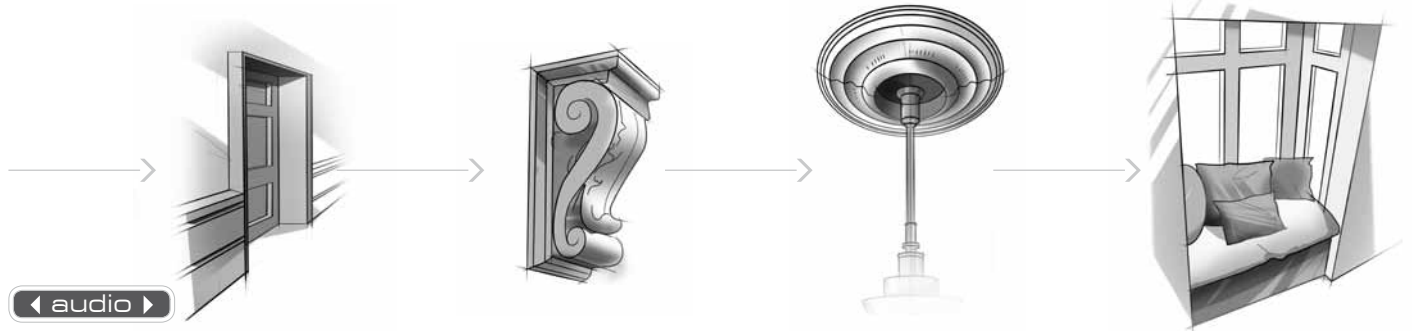

IV. Read the definitions carefully and complete the table with the words below.
The first one has been done for you. Then listen to check your answers.

niche, baseboard (= Br.E: skirting board), chair rail, pilaster, in-wall fish tank, picture rail, frieze (dentil molding), crown molding, mantelpiece.

recessed ceiling	a kind of suspended, (false, drop) ceiling
_____	a rectangular column, typically topped with a capital or corbel and trim for a base
_____	surrounds a room at chair back height to prevent scuffing and damage to the walls
_____	a recess in a wall especially for a statue
_____	surrounds a room near top of the wall to facilitate hanging pictures. It can range from a shallow shelf to slotted trim to accept picture hooks
_____	a molding covering the joint of a wall and the adjoining floor
_____	a sculptured or richly ornamented band (as on a building or piece of furniture). As architectural detail, it surrounds the room just below crown molding.
_____	surrounds a room where the wall meets the ceiling to hide uneven surfaces and provide visual interest
_____	a: the finish around a fireplace b: a shelf above a fireplace
_____	a glass case in the wall where you can keep fish

V. Bases are universally used to finish the area where the wall and floor meet. Baseboard is the term used for wood bases only. Below there are three functions of bases.

Complete them with the verbs: *form, cover, are.*

1. They _____ any discrepancy or expansion space between the wall and the floor.
2. They _____ a protection for the wall from cleaning equipment.
3. They _____ a decorative feature.

VI. Have you any idea how to install architectural details in a room? Try to put the necessary activities in order. The first one has been done for you.

1. Collect the proper tools.
- If the final effect is pleasing, plan the installation by measuring and specifying the needed stock.
- Nail a sample trim or molding in place to see if the result is satisfactory.
- Create a sample board that includes wallpaper, flooring, paint, trim, tile and fabric swatches.
- Paint the sample trim or molding to get the final effect.

VII. Find the names of 14 remodeling tools in the word snake.

brush drop cloth hammer insulating foam level measuring tape nail putty knife rollers saw screwdriver spatula sponge

VIII. Stairs can be an important feature in a building. Can you name their functions?

Look at the sentences below and complete them with the following verbs:

take, provide, link, determine.

1. They _____ the position of services within the overall layout.
2. They _____ you vertically from one level to the next.
3. They _____ the different parts of a big building together.
4. They _____ good overall circulation.

IX. Find a picture of stairs and mark the following parts on it: *landing, banister, tread, handrail.*

Select the correct word:

1. To make a room appear cosier, choose colours from the *warm/cold* side of the colour wheel.
 2. A warmer shade used on the ceiling will bring the height of a room *down/up*.
 3. The far end of a long corridor will seem closer if painted in a *darker/lighter* shade.
 4. To make a room appear *larger/smaller*, choose colours from the cool end of the colour wheel.
 5. Keep flooring dark and walls light, the floor space will appear to *shrink/expand*.
 6. A low ceiling will appear *lower/higher* if painted a lighter shade than the walls.
 7. Vertical lines bring the ceiling *up/down*.
 8. Horizontal lines make the room feel *lower/taller*.
-

Before reading, check the meaning of the following words: *medieval, warehouse, canopy*.

The typical medieval Dutch house survived into the Renaissance era. It was a narrow, multi-story building, where the ground floor was often a shop, the top floor a warehouse. The living floors between generally had large windows that took advantage of the increasing availability of glass, plain white walls, and a floor of marble squares or tiles. Wood came to be used for some paneling or trim. Pottery and tiles made in Delft were a distinctive part of the Dutch decorative vocabulary: plates and platters were treated as decorative display items, while tiles with painted images edged the walls. (...)

Classical elements, mouldings and columns appear as ornament on the exteriors of buildings, but only to a limited extent in interiors. Furniture was often large in scale and handsomely detailed. Beds were often enclosed in built-in, box like Dutch bed spaces or, when free-standing, were canopied and draped. Oriental rugs, (...) appear as table covers, but only rarely on floors.

Answer the questions:

1. What did the living rooms in medieval Dutch houses look like?
2. Was wood widely used?
3. How were pottery and tiles utilized?
4. Did Dutch houses feature classical elements?
5. What was furniture like?
6. Can you give example of artworks which show medieval/Renaissance interiors?



The exercises must be done on the basis of the film dialogues.

I. Watch the film and then select the correct answer:

1. Zoe is planning to photograph the place because:

- a) the interior is plain and simple
- b) the interior is modern and light
- c) the interior is traditional and light

2. The recessed ceiling resembles:

- a) the traditional medallion
- b) icing on a cake
- c) in-wall fish tank

3. The baseboard is:

- a) non-existent
- b) eye-catching
- c) plain

II. Listen to the film dialogue carefully and circle the words that you hear:

relief modules
 recessed ceiling
 frieze
 suspended ceiling
 rosette
 canister downlights
 fluorescent tube
 traditional setting
 stair tread
 contemporary feel
 trim and moulding
 wallpaper
 eye-catching fireplace
 in-wall fish tank
 handrail
 sample board

III. Decide if the following sentences are true or false:

1. The wall is made from plastic.
2. The recessed ceiling is a base for downlights.
3. There are too many architectural details in the room.
4. Rooms with contemporary feel utilize elaborate trim.
5. The wardrobe is the focus of the room.

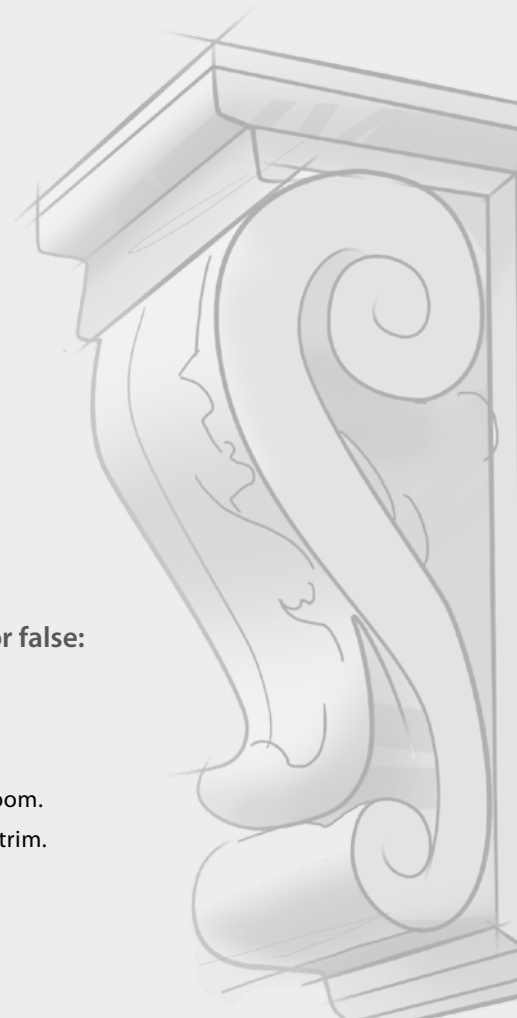

I. Read the following definitions:

Flooring is the general term for a permanent covering of a floor, or for the work of installing such a floor covering. Floor covering is a term to generically describe any finish material applied over a floor structure to provide a walking surface. Both terms are used interchangeably but floor covering refers more to loose-laid materials.



Decide which material describes **floor covering**, and which describes **flooring**, according to the definitions above. Then listen and repeat.

wood flooring

rug

ceramic tile

linoleum

carpet

resin

stone

terrazzo

II. Read the features of **hard floors** in general and write a [+] next to pros, and a [-] next to cons, according to your opinion.

- | | |
|--|---------------------------------------|
| • long lasting | • easy cleaning |
| • elegant | • expensive |
| • cold to the touch (may need under-floor heating) | • retains heat |
| • low maintenance | • most require reinforced subflooring |
| • reflects noise | |

III. There are several types of **stone floors**, e.g. *flagstone* – thin slabs of stone used for paving walks, driveways, patios, etc. Arrange the letters in the following words to find names of other stone floors: *blerma, nitegra, vertraneti, tesla*.

IV. Complete the texts about tiles with the following words:

patina, moisture, heat, patterns, clays, imitate, stone, easy, embossed.

TILE: This impenetrable floor is available in a variety of sizes ranging from 1 sq foot to 1 sq inch. Excellent for high traffic and _____ – prone areas. Tile comes in many types, finishes, colors and _____. If unable to afford an under-floor heating system, consider burnished terracotta tiles which retain _____ well. Ceramic tiles can feature designs baked onto the tile and are used to simulate _____.

CERAMIC TILE: These are the most waterproof of all the tiles and come in a broader range of colors and embossed designs than other tiles. Commonly used to _____ genuine stone tiles. Ceramic tiles are thinner, yet more dense, making them _____ to install and waterproof. Finishes include glazed, matte, _____, or textured for anti-slip.

QUARRY TILE: is a strong, hard-body tile made from carefully graded _____, with color throughout the body. The unglazed surface of quarry tile develops an attractive _____ with wear. The grout is either cement mix or epoxy resin with a silica filler.

V. Now read the descriptions of other types of hard floors and try to match them with their names: *acrylic, metal, glass, concrete.*

- _____ – this is one of the most affordable, as well as durable, choices of flooring. It can be painted to add warmth to a room, and repainted to keep up with changing trends. It is a cold, heat and scratch resistant floor and should be sealed to prevent staining and wear.
- _____ – an original flooring material that is costly. It should have some type of anti-slip mechanism such as sand blasting. Scratching can be a problem, so use in low-traffic areas is best.
- _____ – less expensive than glass with the same attributes. Scratching is much more of a problem than with glass, so use in low-traffic areas is best.
- _____ – stainless steel and aluminum are most common. Embossed patterns like diamond plate create visual interest while reflecting the environment, which can make the room look larger.

VI. Another category includes wood floors. Can you think of advantages and disadvantages? Match the names of types of wood floors to their definitions: *strip, plank, parquet.*

- _____ – small flat blocks of wood fitted together in a pattern that cover the floor of the room.
- _____ – long wide boards that fit together tongue and groove. They usually do not require a subfloor, but are more expensive.
- _____ – narrow boards, may be available preconstructed on large sheets that fit together tongue and groove. Most installations require a subfloor to prevent buckling.

VII. Match the types of parquet flooring with their names: *inlaid parquet, basket-weave parquet, herringbone parquet.*

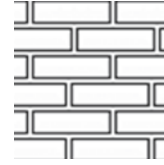
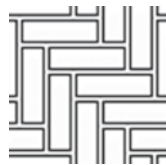

VIII. Listen to the text about carpets and fill in the blank spaces.

- A. Loop pile has a surface consisting of _____ loops. Variations include _____ and low loops and various colours.
- B. Cut pile (plush) is manufactured with looped material and cut for a _____ finish. This is a very basic style of carpeting. This textured carpet hides _____ and traffic patterns and is easy to work with.
- C. Freize (hard twist) is cut pile from a highly twisted yarn. It will hide footsteps, prevent shedding and the shading which occurs when the pile lies in opposite directions.
- D. Semi-shag (splush) is _____ cut pile with shorter piles than shag.
- E. Shag is a soft carpet with _____ pile.
- F. Berber carpet is made by machine with a _____, homespun effect with natural colours. Thicker yarns hide both _____ and _____ tracks. Usually coarse loop pile, but also made in cut pile, shags and a variety of designs, Berber is most often used in _____ rooms.

IX. Tell your partner what kind of floors you have got in each room. Do you think flooring plays an important role in the character of the interior? What kind of impact can it have?

Here are some tips how to get the Victorian look for your room.

Complete them with appropriate words:

1. Rich and dark colours such as ruby r _____ and forest g _____ are typical.
2. Wallpaper came into mass production so paper your room from the s _____ board to the d _____ rail.
3. Crowd the room with furniture, plump a _____s, pouffes or o _____s.
4. The Victorians like paint effects. Try f _____ marbling or stenciling.
5. F _____s were ornate, always with a mantelpiece.
6. Decorative m _____s like corbels or cornices are essential.
7. Paint or s _____ the outside stair treads a dark brown.

Before reading, check the meaning of the following words: *dormer, joinery, pitched, immaculate*.

Dating back to the 19th century, this property in Whitestone was kept in the family for two generations. The period house has been lovingly maintained and improved during recent years with LPG central heating being installed.

The well-proportioned rooms have good ceiling heights and still retained their wide panelled doors. Period features include dormer windows, high moulded skirting boards and some slate flagged floors.

Mention should also be made of the fine period joinery, particularly the pitched pine staircase with mahogany banister rail.

The detached house is in immaculate decorative order and has an impressive reception room, a large lounge/dining room, a kitchen with separate pantry, a large conservatory, five bedrooms and three bathrooms (one en-suite to the master bedroom).

There is a utility room, a cloakroom and a study on the ground floor as well as an indoor heated swimming pool. In addition to a large garden at the front of the house there is a garage and a storage shed.

The house occupies a south-facing location with views for many miles. The sole agent Stags (01392255202) is indicating a guide price of £895,000.

Complete the information about the property on sale:

Location:

Accommodation:

Outside:

Price:

Agent:



The exercises must be done on the basis of the film dialogues.

I. Watch the film and then select the correct answer:

1. Zoe's living room features:

- a) wooden boards
- b) old ceramic tiles
- c) new ceramic tiles

2. Baseboard is made from:

- a) vinyl
- b) ceramics
- c) wood

3. Cork floor is water resistant when you:

- a) spill red wine on it
- b) mop it with a wet mop
- c) treat it

II. Listen to the film dialogue carefully and circle the words that you hear:

impenetrable
pine
oak
elm
ash
maple
herringbone
tongue and groove
skirtings
subflooring
flagstone
maintenance
vacuuming
embossed
extruded

III. Decide if the following sentences are true or false:

1. Zoe likes her ceramic tiles very much.
2. Ash wood isn't as hard as oak.
3. Herringbone is a kind of baseboard.
4. Cork floor can be cleaned with a broom.
5. Cork is environmentally-friendly type of flooring.

I. Answer the questions:

- Rearrange the letters in the following words to find some types of wood: *sha, echeb, chirb, mle, aplem, kao, nipe*. Do you know which of them are softwoods, and which are hardwoods?
- What can be windows made from except for wood?
- Think of different reasons for purchasing new windows.



II. Match the names of types of windows with their definitions. Then listen to check your answers.

sash window, jalousie window (also known as a louvered window), skylight, roof window, horizontal slider.

- _____ – a flat or sloped window used for daylighting, built into a roof structure that is out of reach.
- _____ – a sloped window used for daylighting, built into a roof structure that is within reach.
- _____ – consists of parallel slats of glass or acrylic that open and close like a Venetian blind.
- _____ – the traditional style of window in the USA, and many other places that were formerly colonized by the UK, with two parts (sashes) that overlap slightly and slide up and down inside the frame.
- _____ – has two or more sashes that overlap slightly but slide horizontally within the frame.

III. Have a look at the pictures of various windows and match them with their names:

bay window, casement window, pivoting window, picture window.

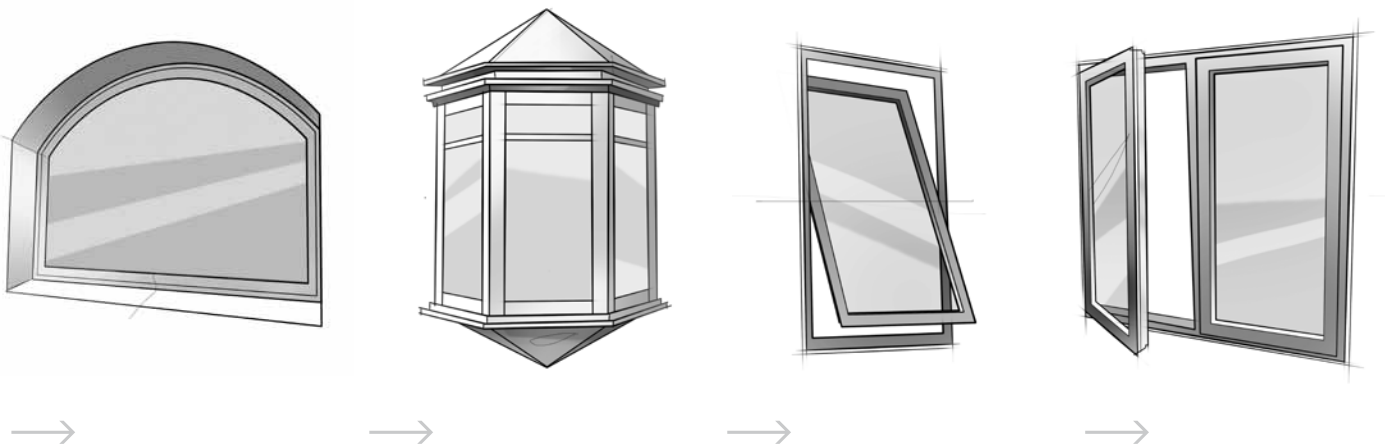

Now make a list of different rooms in a house. Then have a look at the types of windows and think what room they can be mostly fitted in.

IV. What are the functions of window coverings? Complete the sentences with the following verbs: *provide, decorate, manage, ensure*. You can use each of them once.

Window coverings are used to:

- _____ sunlight,
- _____ additional weatherproofing,
- _____ privacy,
- _____ the interior.

V. Have a look at the pictures of various window coverings and match them with their names: *shutters, roller (cellular) shades, Roman blinds, curtains, draperies, Venetian blinds (horizontal blinds), vertical cloth tapes.*

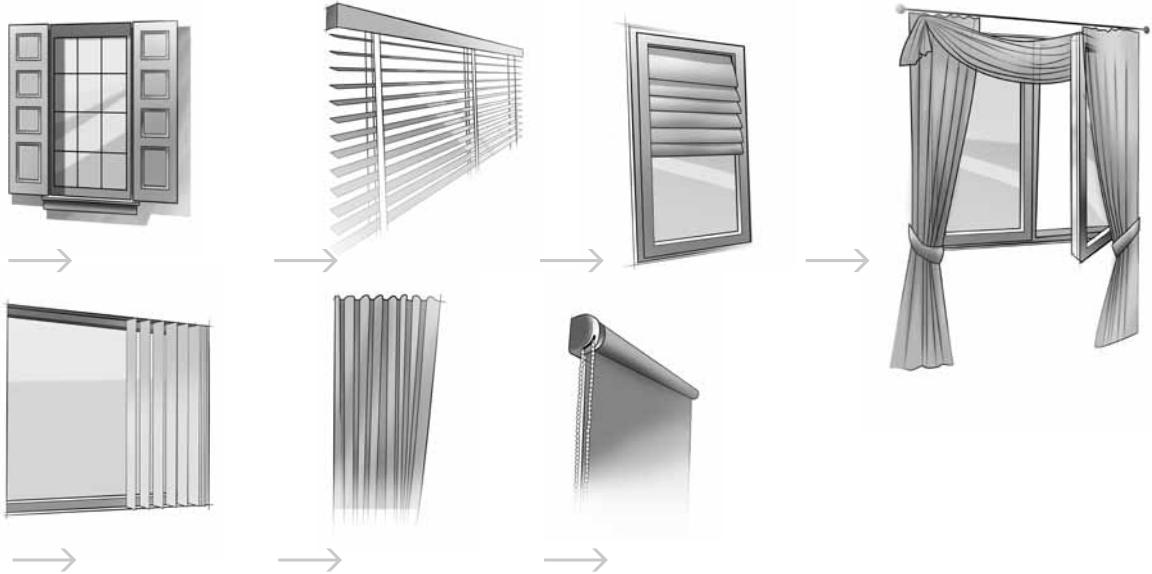

VI. What are the functions of doors? Complete the sentences with the following verbs: *allow, screen, have, exclude, admit, act, control, prevent.*

1. _____ passage between the inside and outside, and between internal rooms.
2. _____ ventilation and light (when open).
3. _____ the physical atmosphere within a space by enclosing it.
4. _____ air drafts, so that interiors may be more effectively heated or cooled.
5. _____ the spread of fire.
6. _____ as a barrier to noise.
7. _____ areas of a building for aesthetic purposes, keeping formal and utility areas separate.
8. _____ an aesthetic role in creating an impression of what lies beyond.

VII. Have a look at the pictures of various types of doors and match them with their names: *sliding door, folding door, hinged door, French door.*

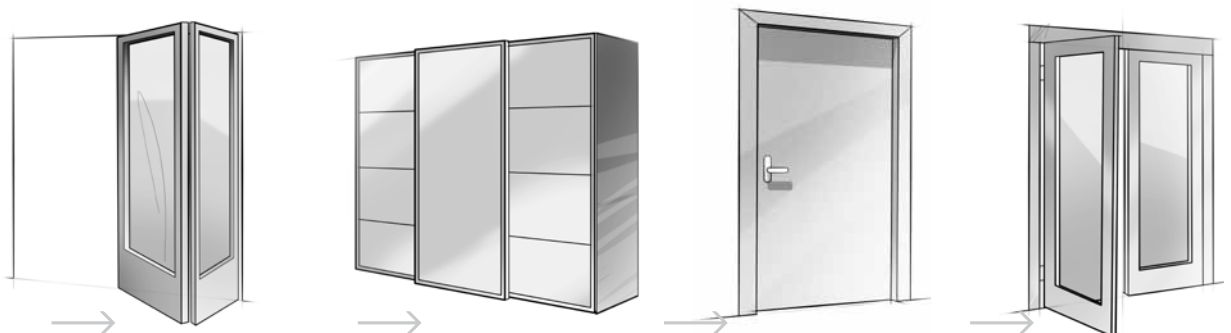

VIII. Read the text on page 86 and write the words below in order according to the amount of light that an object lets through: *opaque, transparent, translucent.*

0% 50% 100%

_____ | _____ | _____

What kind of flooring is suitable to imitate the following period styles? Put the name in the proper place: Japanese, Victorian, Art Deco, Modernism, Scandinavian country, Gothic, Arts and Crafts.

- _____ – plain polished parquet is perfect for floors. Linoleum in abstract designs or black and white chequerboard vinyl tiles are also typical.
- _____ – wooden floors in either parquet or boards in oak give that rustic feel. Polish or stain them to a dark finish.
- _____ – choose from large flagstones or fake the effect with clever stone blocking, which is a paint technique. Floorboards can be stained a dark oak colour with woodstain.
- _____ – should be tatami mats. These are best described as half seating, half flooring. You can buy them but they are quite pricey. To imitate the look, buy cheap mats, the sort you get at seaside shops. You could have paper flooring as well. Remember to leave your shoes outside.
- _____ – flooring should blend seamlessly from one room to another. Choose wall-to-wall fitted carpet in a neutral shade or, if that's too impractical, lino or quarry tiles.
- _____ – floors should be bare floorboards. The wider the planks the better. Choose roughly chopped boards for that peasant look. You could paint them off-white with a whitewash, or use a lye treatment, where lye is applied to the floorboards to draw out the yellow of the pine, and then is oiled to a milky white finish.
- _____ – lay patterned carpets with a faded grandeur, leaving a border of polished floorboards. Floorcloths, a canvas painted with oils and many layers of linseed oil, can be used for less grand rooms.

Before reading, check the meaning of the following words:

cluster, masonry, austere, tapestry, clerestory, ultimately.

[Louis] I. Kahn was deeply concerned with expression of materials and with the ways in which light reveals form and creates the nature of interior spaces. The Unitarian church in Rochester, New York (1959-69) is a cluster of multipurpose rooms surrounding a central church sanctuary, where light enters from windows high up on roof projections. The windows cannot be seen from most positions within the church – the light seems to enter from mysteriously invisible sources. With its simple, gray masonry walls the space is austere, but it is enlivened by brightly colored fabric tapestry hangings by Jack Lenor Larsen. The effects of light in relation to the limited color create an atmosphere that is powerfully moving.

As his reputation grew, Kahn's practice became international. (...) The National Assembly building in Dhaka is a cluster of cylindrical and rectangular masonry units with round and triangular openings into interior spaces. They surround a central assembly chamber with a vault-like roof and high clerestory windows.(...)

The Kimball Art Museum in Fort Worth, Texas (1966-72) is a single-story building, a kind of pavilion that is made up from parallel concrete vaulted elements where light is led from hidden sources at the top of each vault. Artificial light comes from the same location as daylight. As a teacher, Kahn tended to speak in mystical phrases about form, light, and materials, in a style which had a fascination for his students, and, ultimately, for the design professions that came to regard him as a prophet and leader.

Answer the questions:

1. What was L. I. Kahn's deepest concern?
2. Where does light come from in the church in Rochester?
3. How is the moving atmosphere created?
4. What is the shape of the openings in the national Assembly building in Dhaka?
5. What are the sources of light in the Kimball Art Museum?
6. Why did the design profession regard Kahn as a prophet and leader?



The exercises must be done on the basis of the film dialogues.

I. Watch the film and then select the correct answer:

1. There are:

- a) bay windows
- b) sash windows
- c) casement windows in Zoe's flat

2. Zoe is thinking about buying:

- a) vertical cloth tapes
- b) Roman blinds
- c) Venetian blinds

3. Tomasz:

- a) recommends a friend who can measure windows
- b) does not know how to measure windows
- c) offers his help in measuring windows

II. Listen to the film dialogue carefully and circle the words that you hear:

- window treatment
- frame
- double-glazed windows
- louvered windows
- roof windows
- glass
- horizontal slats
- cellular blinds
- skylights
- opaque
- vertical cloth tapes
- shutters
- arcade
- drafty
- layout

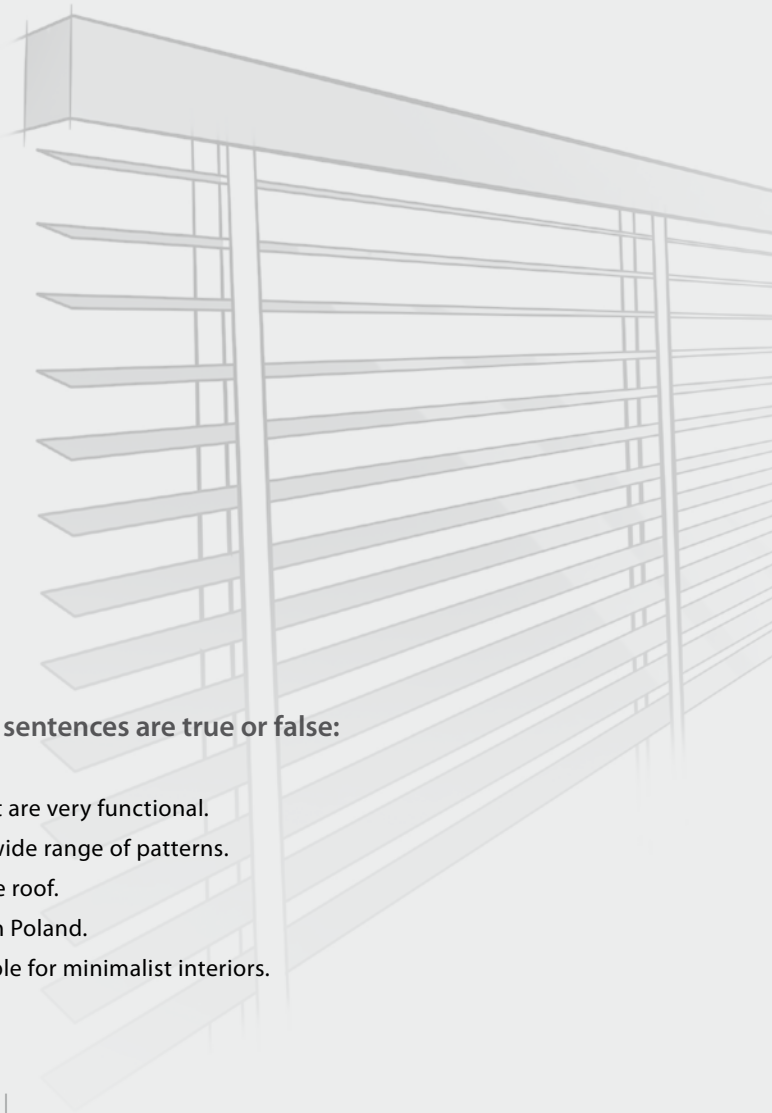

III. Decide if the following sentences are true or false:

1. The curtains in Zoe's flat are very functional.
2. Cellular shades offer a wide range of patterns.
3. A skylight is put into the roof.
4. There are no skylights in Poland.
5. Roman blinds are suitable for minimalist interiors.

I. Answer the questions:

1. Name the appliances that are typically used in a kitchen.
2. What appliances make the tops of the imaginary work triangle in a kitchen?
3. What are the pros and cons of a closed and open kitchen?

II. Decide if the sentences below the text are true or false.

Regardless of the type of kitchen desired, there are some basic requirements for all kitchens. The appliances and work areas most used in a kitchen are the refrigerator for food storage, the stove for cooking and the sink for washing. The work triangle connects these three areas, and the total distance should not be over 22 feet and may be less than that in some smaller kitchens. The distance between the refrigerator and the sink should be 4 to 7 feet, with 4 to 6 feet between sink and stove, and 4 to 9 feet between stove and refrigerator. Besides an efficient work triangle, adequate lighting and adequate storage are important.

1. Different kinds of kitchens have to meet the same fundamental principles.
2. The sink is the single most used appliance in a kitchen.
3. The overall distance between the three most important appliances should not be over 220 cm.
4. The work triangle may be an equilateral triangle.



III. Complete the sentences with the following words:

open, enjoyable, availability, access, vaulted, expense, couple.

Then listen to check your answers.

The type of kitchen desired depends upon _____ of space, lifestyle, and ages and number of family members. _____ and space are the limiting factors in kitchen design. The best utilization of space will create a functional and _____ working area. A small kitchen will appear larger with an _____ plan, that is, without a wall dividing it from the adjacent room. It will also appear larger with a _____ ceiling. A young _____ with a beginning family might require a family room within the sight of the parents. Teenagers like to be near food preparation areas for easy _____ to refrigerator and snacks. All these factors need to be taken into consideration when planning a kitchen.

IV. There are infinite variations on four basic floor plans. Match the floor plan with the picture:

corridor, Pullman, U-Shaped, L-Shaped.

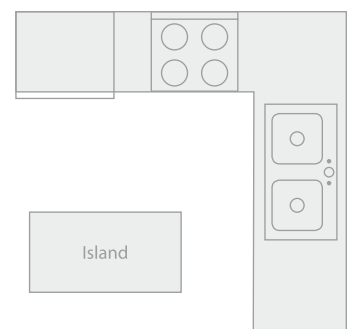
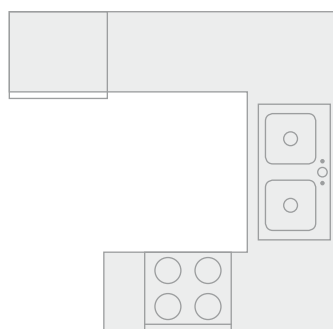
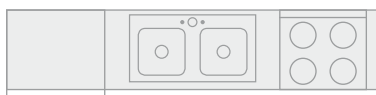

V. Now write the names of the floor plans in the appropriate space in the text:

The simplest of all kitchen floor plans is the one-wall, otherwise known as _____, strip or studio. Here, all appliances and counter space are contained on one wall and, when required, folding doors or screens are used to hide the kitchen completely from view.

This is a minimal kitchen not designed for elaborate or family meals.

The _____ or two-wall plan utilizes two parallel walls and doubles the available space over the one-wall plan. The major problem with the design is through traffic. If possible, for safety's sake, one end should be closed off to avoid this traffic.

In an _____ kitchen work areas are arranged on two adjacent walls rather than opposite ones. (...) This kitchen may also include an island or a peninsula. If the island has a raised side facing an eating or seating area, the higher side will hide the clutter in the kitchen.

The _____ kitchen is probably the most efficient design and the easiest to arrange. It has three walls of counter space, with no through traffic.

1. Which one is the simplest of all kitchen floor plans?
2. What is the main problem with the corridor kitchen plan?
3. Which plan is the easiest to arrange?
4. How can the strip kitchen be hidden from view?
5. What is the function of the raised side of the island?
6. Is there through traffic in the U-Shaped kitchen?

VI. Find 12 names of kitchen appliances in the word snake:

refrigerator freezer cooking range microwave cooking top oven hood dishwasher sink kitchen faucets kitchen cabinets

VII. Answer the following questions concerning bathrooms:

1. What are the three basic fixtures that all bathrooms have?
2. What factors have to be considered when planning a functional bathroom?
3. Think of your bathroom. What bathroom accessories does it have?

VIII. Complete the text with a word opposite to the word in brackets. The first letter is given.

The most economical arrangement of fixtures is against a single (dry) w_____ wall. Economy, however, is not the only factor to be considered. Plumbing codes, human comfort and convenient use require certain (maximum) m_____ separation between and space around fixtures. The location of the door is extremely important. The door should be located (thoughtlessly) t_____ so that it will not hit a fixture because it will (initially) e_____ cause damage both to the door and the fixture. All bathroom fixtures come in white, and also in (individual) s_____ colours that are 20 percent more expensive. Care should be taken not to select fad colours that will become (fashionable) d_____ because bathrooms fixtures are both (easy) d_____ and expensive to replace when remodeling.

What kind of window or window treatment is suitable for the following period styles?

Put the name in the proper place: *Georgian, 1950s, Scandinavian country, Modernism, 1930s, Edwardian.*

- _____ : for shades choose between bright colours such as red, lime green, yellow, black, and delicious ice cream shades such as pistachio green, bubblegum pink and pale blue.
- _____ : position stained glass in the top panel of front windows, and panels in French windows and doors.
- _____ : hang pieces of lace at the windows and then add plain or floral curtains to co-ordinate with the walls. Alternatively put up a simple striped roller blind.
- _____ : original properties had sash windows and shutters.
- _____ : windows should be as plain as possible to let maximum light in. Hang simple curtains in natural fibres such as linen or a slub cotton from plain wooden poles or tracks. Otherwise hang plain white Venetian blinds.
- _____ : hang plain muslin instead of curtains or hang simple curtains from a wooden curtain pole.

Before reading, check the meaning of the following words:

drainboard, slick, to poke up, gleaming, eligible.

Industrial design, with its connection to Art Deco and its love of streamlining, came into the homes of the twentieth-century middle classes through kitchens and bathrooms rather than more formal living spaces. Kitchens, even after the introduction of electric appliances, had remained rooms housing a collection of unrelated items – the cooking stove, the ice-box (now electrified) and the sink and drainboard unit, each in forms that dated back to the early nineteenth century. Industrial designers persuaded manufacturers to transform the old wooden ice-box into a slick, white, mildly streamlined form. (...)

White and smooth surfaces then became the norm for ranges (...). These simple cubical forms with their standard-height flat counter tops, suggested to many designers and manufacturers the idea of continuous counters that could be topped with metal or linoleum to produce a laboratory-like band of equipment. Only the smooth refrigerator needed to poke up above the line. With gleaming white cabinets and smooth tops, banks of overhead cabinets and floors of colorful linoleum became favourite elements in the houses of the 1930s.

Bathrooms also became eligible for modern treatment, with a built-in tub and shower, and often with washbasins made into cabinet units. The makers of plumbing fixtures became enthusiastic clients of industrial and interior designers, who produced model bathrooms in bright colors and advertised them in magazines.

Answer the questions:

1. What appliances were housed in the kitchens at the end of the 19th century?
2. What transformation did ice-boxes undergo?
3. How did counter tops start to look like?
4. What was the standard colour in the kitchen?
5. Did changes affect bathrooms?
6. Was there a standard colour in the bathroom?



The exercises must be done on the basis of the film dialogues.

I. Watch the film and then select the correct answer:

1. The range of bathroom fixtures is:

- a) limited
- b) wide
- c) rather varied

2. Displays of bathroom fixtures are:

- a) on the ground floor
- b) on the first floor
- c) in the basement

3. The glass door is:

- a) folding
- b) sliding
- c) pivoting

II. Listen to the film dialogue carefully and circle the words that you hear:

quarry tiles
 porcelain tiles
 anti-slip
 moisture-prone
 soap bowl
 bidet
 streamlined
 faucets
 washbasin
 angular
 sleek
 sideboard
 top-of-the-range
 top-of-the-line
 undemanding
 unobtrusive



III. Decide if the following sentences are true or false:

1. A designer should obtain information about materials, shapes and sizes in bathroom design.
2. Cleaning is easier when the toilet hangs above the floor.
3. The shape of the washbasin and the cabinet are similar.
4. The mirror is installed in a modern way.
5. The recess is a dark space.

I. Read the text below and complete the gaps with the following adjectives: warm, light, spacious, dramatic, dark, living, charming, clever, false, poor, natural.

Made to Measure

Filled with light, a small three-roomed apartment in Paris takes on the appearance of a _____ loft thanks to a _____ and airy layout. Before redecoration it was a 42 m² three-roomed apartment in pretty _____ condition, but the price was attractive, and it had a terrace overlooking the roofs of Paris. The owner, Pierre, asked an architect Jean Dufoux to tackle the transformation for him. He was immediately convinced by the project which made the most of the existing space. The work lasted four months. All the partitioning walls were knocked down to create one large room where the light streamed in from both sides. The floors were stripped and a light concrete base was laid and then covered by a parquet flooring. It runs throughout the apartment and gives it a sense of unity. A bedroom was fitted in the loft space to free the rest of the space for a large living room. Thus the apartment looks more like a _____ little house. Pierre also followed the advice of an interior decorator friend of his for the choice and layout of the furniture and the light fittings. Thanks to his friend the apartment is _____ and welcoming and reflects Pierre's preferences and way of life. In the living space, Pierre played on the colour contrasts with a _____ table and _____ sofas which were made to measure (slightly smaller than standard), to fit the space. In the kitchen, the light fittings were hidden in the _____ ceiling. The brown colour and the dark tiles create quite a _____ effect in the well-designed room where every inch of space has been put to good use. A 1960 metal lamp reinforces the design features. A small stair leads to the bedroom on the mezzanine. The bamboo lamp and the holes in the stairs add lightness to the effect. Upstairs, the bed has been deliberately kept low for maximum headspace. The Velux window brings in the _____ light into the bedroom. The top of a side table is used as a bedside table. It seems that those involved in this project worked in perfect harmony to create a pleasant and welcoming _____ space.

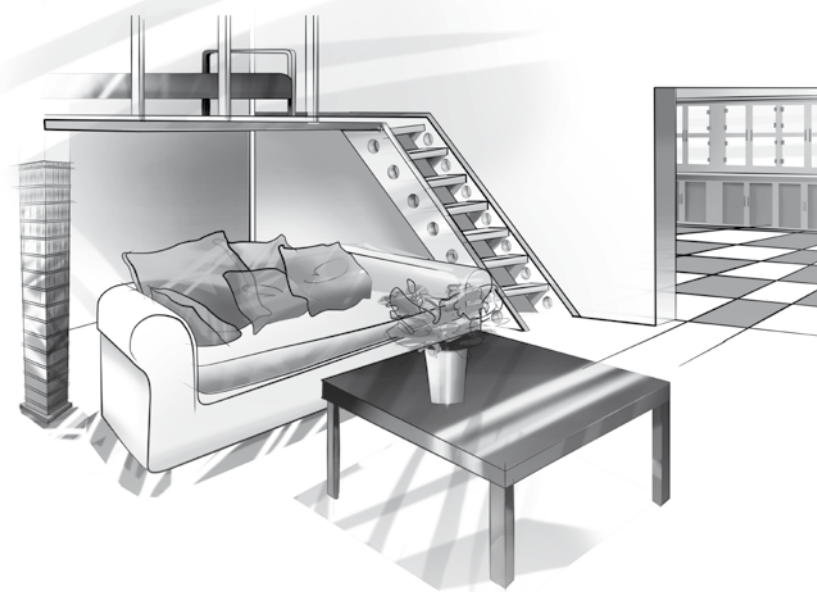

II. Try to match the verbs with their complementing phrases without looking into the text in ex. I. You can use each of them once. Then listen to check the answers.

- | | |
|---------------|----------------------------------|
| 1. take on | a. a sense of unity |
| 2. make | b. the colour contrasts |
| 3. knock down | c. the design features |
| 4. give | d. the appearance |
| 5. fit in | e. lightness |
| 6. play on | f. the partitioning walls |
| 7. reinforce | g. natural light |
| 8. add | h. the bedroom |
| 9. bring in | i. perfect harmony |
| 10. create | j. the most of an existing space |

III. Read the text in ex. I again and make notes of the following elements of interior design:

- | | |
|---------------------------|-----------------------|
| 1. furniture | 5. paints and colours |
| 2. flooring | 6. windows |
| 3. lighting | 7. materials |
| 4. arch. details and trim | 8. overall impression |

IV. Read the text below and complete the gaps with the following adjectives:

authentic, cosy, original, huge, gentle, stone, sheer, local, arched, bay.

A Gentle Retreat

Carefully restored, this Templars house has revealed its _____ vaults in a natural atmosphere of simplicity. (...) When Natalie and Bruno first discovered this Templars house with its inner courtyard (...), they decided it was the ideal place to live with their children. They needed a lot of imagination to rethink the layout and the volumes and a lot of courage to tackle the work. It took four years for the couple to achieve their objectives with the help of the local craftsmen, carpenter and iron specialist. The kitchen was housed in the old cellars where the ceiling was totally restored and the flagstones cleaned and scraped one by one before being rubbed with linseed oil. But a window was needed to bring light in and make the most of the outside view. The _____ design is reminiscent of the vaults and adds a sense of _____ harmony. The kitchen is divided into three areas, one for washing and cleaning, another for preparing meals, and an eating corner. In the living room, some of the walls were knocked down to give a large area and bring more light in. The living room set between the kitchen and the stairs is the hub of the house. It is a place where one can listen to music, watch television or just sit by the large _____ fireplace. The stairwell goes full height to the roof looking like a chapel. It shows the _____ architecture of the house, attracting the attention to the volumes and the _____ stones and bringing light in. On one of the walls, a _____ church clock (...) adds a decorative and symbolic touch. The decoration is simple and elegant with natural materials, white or grey-blue washes, and coppery wooden or terracotta floors. Light curtains hang over the large windows. Light grey linen sofas and Provencal furniture complete the _____ decorative scheme. The inner courtyard, filled with plants and flowers, leads to the orangery which was housed in an outbuilding. This is where the delicate plants are stored in winter. One of the walls was fitted with a large _____ window which offers a magnificent view over the pink roofs of the village. It is a place where the couple likes to receive friends and family for lovely dinner parties cooked in the specially fitted kitchen. In this house, where the peace is only disturbed by the chiming of the church bells, life goes on happily with (...) the visits of friends who come to share a moment of _____ pleasure.

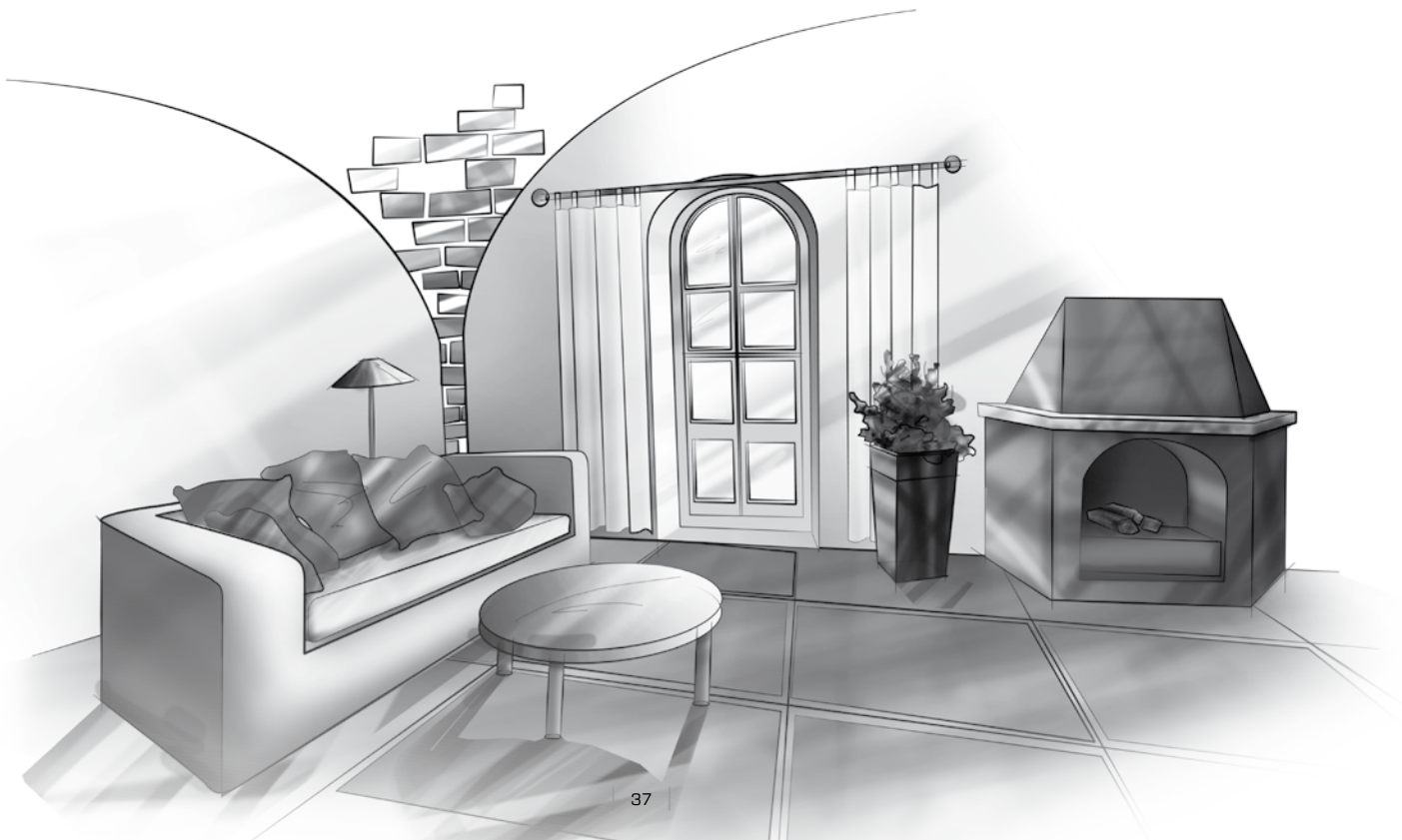

◀ audio ▶

V. Try to match the verbs with their complementing phrases without looking into the text in ex. IV. You can use each of them once. Then listen to check the answers.

1.	rethink	a.	the kitchen
2.	tackle	b.	the flagstones
3.	restore	c.	the attention
4.	house	d.	the layout
5.	scrape	e.	a symbolic touch
6.	rub	f.	a view
7.	attract	g.	the scheme
8.	add	h.	the ceiling
9.	offer	i.	with linseed oil
10.	complete	j.	the work

VI. Read the text in ex. IV again and make notes of the following elements of interior design:

- | | |
|---------------------------|-----------------------|
| 1. furniture | 5. paints and colours |
| 2. flooring | 6. windows |
| 3. lighting | 7. materials |
| 4. arch. details and trim | 8. overall impression |

VII. Have a look at the renderings of MFA diplomas on pages 96-97 and make notes on the following elements of interior design:

- | | |
|---------------------------|-----------------------|
| a. furniture | e. paints and colours |
| b. flooring | f. windows |
| c. lighting | g. materials |
| d. arch. details and trim | h. overall impression |

Now, in pairs, prepare a description of one of the two interiors, making use of the points above and the expressions that you have learnt from the previous texts. Then change your partner and tell him/her as much as you can about your interior.

VIII. Read what the graduating students themselves wrote about their diploma works on page 86 and compare with your descriptions.



The exercises must be done on the basis of the film dialogues.

I. Watch the film and then select the correct answer:

1. The host has to:

- a) make a cup of coffee
- b) phone someone
- c) make something at home

2. The room is:

- a) a study
- b) a living room
- c) serves many functions

3. Natural light is provided by:

- a) sash windows
- b) skylights
- c) picture windows

II. Listen to the film dialogue carefully and circle the words that you hear:

beige
cream
rosewood
solid wood
stairwell
swivel chair
cantilevered
spotlights
textile shade
eyeballs
supporting poles
mezzanine
scheme
decorative feel
cosy
arched

III. Decide if the following sentences are true or false:

1. There is a textile-upholstered chair in the room.
2. Horizontal beams give the room its distinct character.
3. The mirror features a very decorative frame.
4. The paint on the floor and the walls is glossy.
5. The two areas of the room have different styles.

I. Imagine you work in a design company. A client comes to you and says:

'I want you to design a chair for me'. Sketch the chair.

II. The client's sentence – the statement of intention – is called 'a brief'. The design process consists of 6 stages. First, read the definition of one of them:

Product Design Specification – is a document stating what a not-yet-designed product is intended to do. Its aim is to ensure that the subsequent design and development of a product meets the needs of the user. It is important when designing a product to consider the activities downstream of the design stage. By considering these stages early, you can eliminate problems that may occur later.

◀ audio ▶

Now put the stages in order from the initial to the final stage.

- _____ – DETAIL DESIGN
- _____ – PRODUCT DESIGN SPECIFICATION
- _____ – DESIGN BRIEF
- _____ – MANUFACTURING AND TESTING
- _____ – SALES
- _____ – CONCEPT DESIGN

◀ audio ▶

III. The brief does not contain enough information with which you could start designing.

What questions would you like to ask your client – or your team? Below there are example questions for each category – put the words in order. Then listen to check.

- **Manufacture** – the product our facilities be made can with?
- **Sales** – which the client developing a product are we wants?
- **Purchasing** – or do are in stock order them we have to the parts specified?
- **Cost** – the design isn't cost too much going to to make?
- **Transport** – the right size it is for the transport of method?
- **Disposal** – disposed of how be will it?

IV. Read the text about the PDS and its categories, and complete it with the following words:

products, solution, categories, detail, stage.

This is possibly the most important _____ of the design process. It is important that before you produce a '_____'; there is a true understanding of the actual problem. The PDS is a document listing the problem in _____. It is important to work with the customer and analyse competing _____ to ensure designs are appropriate. A PDS splits the problem into smaller _____ to make it easier to understand. The actual categories can vary but a typical PDS consists of typical categories.

V. Read the explanation of one of the categories of the PDS. You have to complete it with words opposite to the words in brackets:

- A. lead time – the time required from the (final) _____ start of the project to the delivery to the (last) _____ customer. For some products, it may be as (long) _____ as a few weeks. However, for more (simple) c _____ x products, it may be considerably longer. Development time for a (old) _____ car may be several years while aircraft may take ten years from start to finish. In general, the (slower) _____ the product can be introduced into the marketplace, the more successful it will be. This is especially true of (low) _____ technology products such as computers, there is no point introducing a product into the market that is (modern) o _____ e immediately.

Student A: do ex. VI, student B: do ex. VII:

VI. Match the following categories with their definitions: *quantity, ergonomics, testing, standards, maintenance, cost, installation.*

- B. _____ for a product should include **sufficient instruction details so that the customer is able to use the product** and so that the servicing personnel can do any required routine action. It should protect the producer from lawsuits resulting from incorrect operation of their products.
- C. _____ is often determined by a customer specifying how much they are willing to pay or from an analysis of the existing marketplace. **The product will not sell if it is too expensive.**
- D. _____ **investigates how the user interacts with the product.** (E.g. in the case of a car, a requirement might be that the control panels are not more than one metre away from the driver's seat). The designer must consider the target user at the design stage so that the finished product is usable.
- E. The PDS should state who is responsible for **making the product ready for use.** For some products (notably large items of machinery), _____ costs can be comparable with the actual cost of the product, so they need to be built into the selling price.
- F. _____ **checks that the product meets the requirements laid out in the PDS.** For mass-produced products, it will be carried out on a set number rather than every product. For one-off products, or limited numbers, it may be performed on every product to satisfy the customer that his requirements are met.
- G. _____ – **levels of quality that are considered acceptable** and contain information about the requirements for different products.
- H. _____ – **the amount or number of a product** will have a significant effect as to the type of manufacturing processes and materials that can be selected by the design team. A mass-produced product is likely to require investment in automated production processes and special tooling, while a batch or a one-off production run will not require such a large investment.

VII. Match the following categories with their definitions: *appearance, disposal, copyrights, product life, patents, competition, performance.*

- 1) _____ can be used to describe two different things:
 - a) **the amount of time a product is expected to operate correctly in service without the need for major overhaul.** It will be of major importance when the product is being designed. A manufacturer will acquire a bad reputation and loose sales if their products are known to regularly fail. However, if the project is 'overdesigned' and lasts too long, the product will be too expensive. The type of guarantee also depends on that factor.
 - b) the length of time a manufacturer will produce a product for before replacing it with a new model.
- 2) _____ – **if there are similar products in the marketplace, it can be useful to research them and document any discoveries.**
A particularly important factor is the selling price of the similar products.
- 3) _____ – **the way a product 'looks'** will have a major influence on its marketability. This is especially true for consumer items such as video recorders, fridges and motor cars. However, it is also true for many industrial products, like milling machines. The appearance of a product must be built into a product at the design stage. A simple way to influence a product's appearance is through the selection of suitable colours and surface treatments.
- 4) _____ – **the main features of the function of a product**, like, for a motor car, what the maximum speed will be or how fast it will accelerate.
- 5) _____ – **what to do with a product after the user has finished with it** should be considered in at the PDS stage. This is especially important if the product contains potentially toxic or dangerous material or chemicals. Any relevant environmental legislation that is relevant to the getting rid of a product.
- 6) _____ – when a new product is developed, it is important to ensure that it does not clash with any **rights to make or sell a product for a certain number of years that have been registered.** If it does, the original holder of the right may take legal action or have rights to royalty payments.
- 7) _____ – **if the product contains written or graphical material, it is important not to violate the rights of the author.**
Material written by another person may be summarised but not copied. Items such as photographs belong to the person who originally took the photograph, so permission must be obtained before using them.
This should be written and not just verbal permission.

VIII. Read some of the phrases in bold letters in ex. VI and VII to your partner and let him/her guess the part of the PDS.

IX. Consider two ergonomic objects in your home. Choose one object that you think is well designed and one that is poorly designed. Bring the objects or their pictures to the class and give a detailed critique of why these two objects represent examples of good and bad design. List the main reasons why each object succeeds or fails in its function, how it could be improved and suggest the features it should or should not include.



The exercises must be done on the basis of the film dialogues.

I. Watch the film and then select the correct answer:

1. Zoe meets Tomasz because:

- a) they have a date
- b) she comes to a lecture
- c) she has free time

2. What make of car is designed?

- a) Nissan
- b) Jaguar
- c) Volvo

3. What kind of associations does Grzegorz have when he thinks about luxury?

- a) high price and cigars
- b) high quality and comfort
- c) cigars and leather

II. Listen to the film dialogue carefully and circle the words that you hear:

assignment
appointment
brainstorming
Jaguar make
disposal
concept
target
lead time
quality
performance
rough sketches
percentile
tables
appearance
diagrams
one-off product

III. Decide if the following sentences are true or false:

1. The design of the car was made for a competition.
2. Zoe thinks that the brief was very simple.
3. A good idea is of major importance.
4. Grzegorz associates luxury with two-seater cars.
5. Anthropometric diagrams were helpful in the process of design.

I. Write the following terms – successive stages of design – in the appropriate boxes:*CONCEPT GENERATION, CONCEPT DESIGN, CONCEPT EVALUATION, DETAIL DESIGN.*

◀ audio ▶

II. Fill in the blanks with the given words. First check their meaning if necessary:*depending, two-stage, diameter, wheels, viable, solution, arrangement.***Then listen to check.****CONCEPT DESIGN**

Using the Product Design Specification as the basis, the designer attempts to produce an outline of a _____. A conceptual design is usually an outline of the key components and their _____. The details of the design are left for a later stage. For example, a concept design for a car might consist of a sketch showing a car with four _____ and the engine mounted at the front of the car. The exact details of the components such as the _____ of the wheels or the size of the engine are determined at the detail design stage. However, the degree of detail generated at the conceptual design stage will vary _____ on the product. This stage of the design involves drawing up a number of different _____ concept designs which satisfy the requirements of the product outlined in the PDS and then evaluating them to decide on the most suitable to develop further. So concept design can be seen as a _____ process of concept generation and concept evaluation.

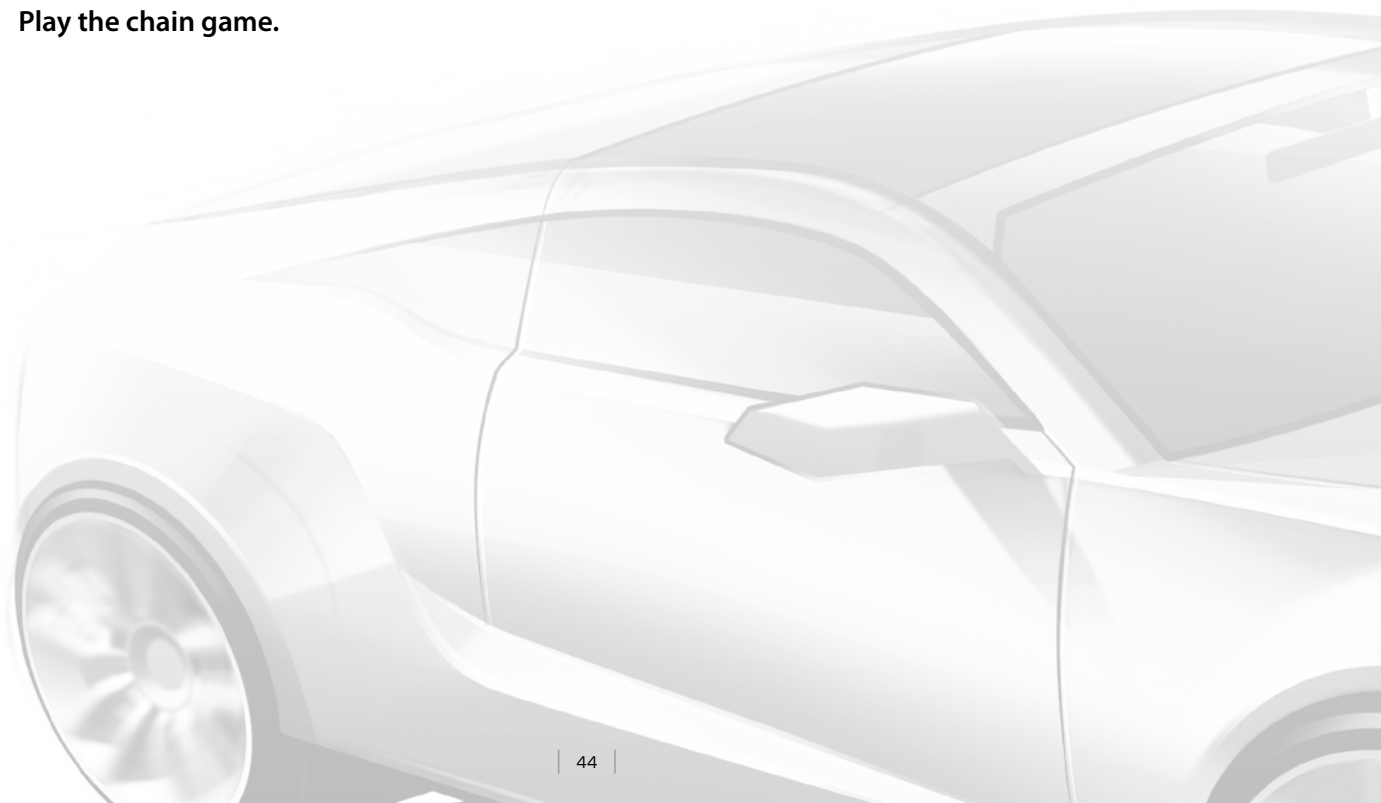
III. Can you give examples of downstream activities? Think of the Product Design Specification.**Play the chain game.**

IV. You are going to learn two terms important for the CONCEPT GENERATION STAGE. These are: annotation (a note added by way of comment or explanation) and brainstorming. Read the text referring to this stage of designing and write the names in the correct places.

Typically, designers capture their ideas by sketching them on paper. _____ helps identify key points on a drawing so that the designers' ideas can be communicated with other members of the company.

There are a number of techniques available to the designer to aid the development of new concepts. One of the most popular is _____. This technique involves generating ideas, typically in small groups, by saying any idea that comes into your head no matter how silly it may seem. This usually sparks ideas from other team members. By the end of a brainstorming session there will be a list of ideas, most useless, but some may have the potential to be developed into a concept.

Do you know any other technique aiding the development of new concepts?

V. Now read the text about CONCEPT EVALUATION. Select the correct preposition.

Once a suitable number of concepts have been generated, it is necessary to choose the design most suitable to fulfil the requirements set (*off/out*) in the PDS. The Product Design Specification should be used as the basis of any decision. Ideally a multifunction design team should perform this task so that each concept can be evaluated (*from/in*) a number of angles or perspectives. The chosen concept will be developed (*by/in*) detail.

One useful technique for evaluating concepts to decide (*on/for*) the best one to use is a technique called 'matrix evaluation'. With matrix evaluation a table is produced listing the important features required from a product – usually this list is drawn (*up/off*) from the important features described in the Product Design Specification. The products are listed (*across/through*) the table. The first concept is the benchmark concept. The quality of the other concepts is compared (*against/to*) the benchmark concept for the required features, to help identify if the concept is better, worse than, or is the same (*than/as*) the benchmark concept. The design with the most 'better than' is likely to be the best concept to develop further.

VI. The last stage of the design process is DETAIL DESIGN.

Read the short text and fill in the missing words: *concept, test, manufacture, design*.

In this stage of the _____ process, the chosen _____ design is developed in detail with all the dimensions and specifications necessary to make a detailed drawing.

It may be necessary to produce prototypes to _____ ideas at this stage. The designer should also work closely with _____ to ensure that the product can be made.

VII. Look at the picture of the car and write the names of its parts in the correct places:
windscreen, rear light, outside mirror, bumper, bonnet, sun roof, boot, grille, headlight, rear-view mirror, windscreen wiper.

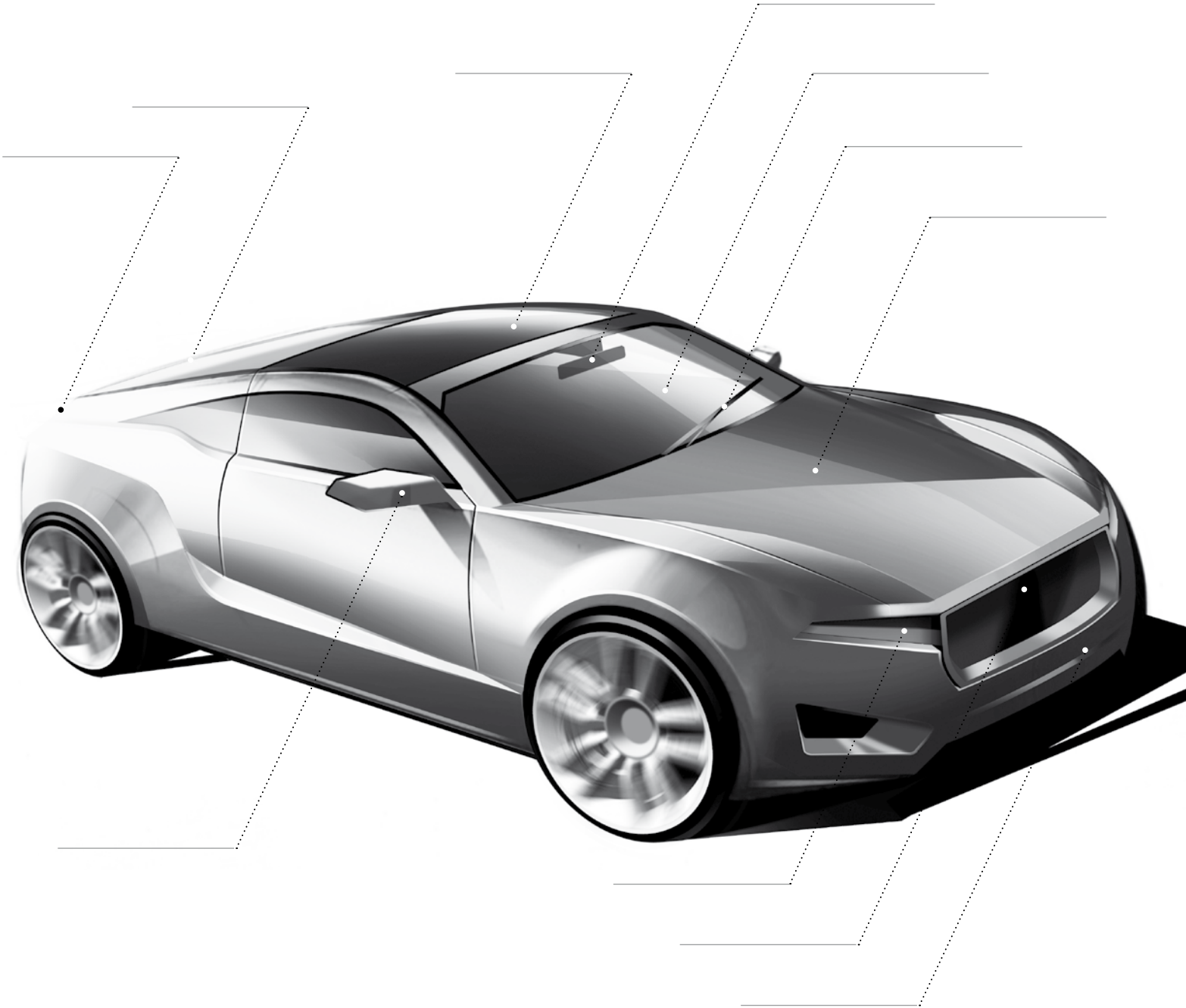

VIII. Find 10 names of types of bodywork in the word snake:

Convertible estate car coupesportscarlimousinesaloonall-terrainvehiclesportsutilityvehiceminibushatchback

Do you know which of the above British names are equivalent to the following American names of cars?

- two-door sedan
- four-door sedan
- multipurpose vehicle
- minivan
- station wagon



Before reading, check the meaning of the following words: *traction, spin, acceleration, kerbside visibility, to toe, whiplash, dashboard.*

Then read the text about three makes of cars and fill in the table below.

1. Every **Murano** automobile comes equipped with a full set of airbags, including driver, passenger and curtain airbags, to ensure the highest level of protection. The Murano's solid 'zone body' construction provides maximum strength in case of collision. The Murano's Electronic Stability Program Plus (ESP+) is linked to an active brake Limited Slip Differential (LSD) to manage engine power and brake pressure. This will maximise traction and control at all times. Delivery of power to the wheels is also constantly monitored by a Traction Control System, which limits wheel spin during acceleration. Murano's Bi-Xenon headlamps use a single high-efficiency bulb for both high and low beams, and give a broader coverage of the road ahead as well as improved kerbside visibility. This technology also benefits the driver, as unlike traditional halogen lamps, the beam resembles daylight. Plus, to increase clarity, the Murano is fitted with flush-mounted headlamp washers. The Murano has three braking systems to ensure you stop safely. ABS (Anti-lock Braking System) prevents the wheels from locking, making it easier to steer around obstacles. Electronic Brake Force Distribution (EBD) automatically regulates the pressure between the front and rear brakes, creating optimum braking even when carrying heavy loads and towing. And in emergency braking, Brake Assist increases the force applied to the brakes.

2. Four airbags – front and side – are standard, protecting you and your passengers. As are active headrests that move forward on impact to help prevent whiplash in the event of a rear collision. Endlessly adaptable, the **Note** car is ready for all eventualities. The front passenger airbag can be turned off when a child seat is placed in the front. And the dashboard LED light is there to remind you when the passenger airbag is deactivated. The **Note** stops as well as it goes. Nissan Brake Assist (NBAS) automatically increases braking pressure, reducing emergency stopping distances by up to 15%. And the Anti-lock Braking System (ABS) monitors each wheel and prevents them from locking – keeping you in control of steering. The Electronic Stability Program, fitted as standard, relies on a range of electronic sensors to monitor wheel speed and steering angle. To help keep you in your intended direction on slippery roads and in emergency manoeuvres, the system reduces engine output and applies braking to individual wheels to correct under- and over-steer.

3. Even with the top down, the **Micra** C+C protects you with its toughness and streetwise handling. The reinforced body keeps you and your passengers safe, even with the roof down. To avoid accidents, standard Nissan Brake Assist and ABS plus Electronic Brake Force Distribution (EBD), coupled with dynamic ESP (electronic stability program) with the 1.6 petrol engine all keep you out of harm's way. Four airbags are standard, protecting you and your passengers. The front passenger airbag can be turned off when a child seat is placed in the front. Beyond the city, the Micra C+C takes control of the road. A specially stiffened body minimises roll and helps the car grip the pavement, providing secure yet agile handling. So driving is safe, yet satisfying and fun. The Micra C+C stops as well as it goes. Nissan Brake Assist (NBAS) automatically increases braking pressure, reducing emergency stopping distances by up to 15%. And Anti-lock Braking System (ABS) monitors each wheel and prevents them from locking – keeping you in control of steering. The Electronic Stability Program relies on a range of electronic sensors to monitor wheel speed and steering angle. To help keep you in your intended direction on slippery roads and in emergency manoeuvres, the system reduces engine output and applies braking to individual wheels to correct under- and over-steer.

	Airbags	ESP+	LSD	Xenon headlamps	ABS	EBD	Brake Assist
Murano							
Note							
Micra							

Which car proves to be the best one?



The exercises must be done on the basis of the film dialogues.

I. Watch the film and then select the correct answer:

1. The brief in ergonomic design was:

- a) to design a dashboard
- b) to design an audiosystem
- c) to design a pulpit

2. The car has got lamps on:

- a) the grille
- b) the steering wheel
- c) the rear-view mirrors

3. In the design process the students had to make:

- a) dummies
- b) mock-ups
- c) prototypes

II. Listen to the film dialogue carefully and circle the words that you hear:

environment
adjustments
annotation
evaluation
ignition
interior trim
hybrid synergy drive
windscreen
headlamps
minivan
touch screen
sunroof
cruise control
sketches
benchmark

III. Decide if the following sentences are true or false:

1. Tomasz liked ergonomics but disliked anthropometrics.
2. Tomasz is not able to reach the brake pedal.
3. The car has got a top-of-the-range engine.
4. The students had to do some driving to start the design process.
5. Zoe can see some mock-ups in the design studio.

I. Answer the questions:

1. What is the difference between artistic drawing and design drawing?
2. Do you prefer to draw or to paint? Why?
3. Make a list of materials that you need to draw. What kind of paper would you need?

II. Match the parts of the sentences.

To master the skill of drawing	of the available space.
Never rub out	a pad of layout paper. You can trace the original sketch and make corrections.
Buy	a ruler on wet ink.
Leave enough space	learn to sketch from your shoulder.
Never place	to add dimensions to the drawing.
Try to make maximum use	an idea. It shows your progress and you may return to it later.

Do you know more rules how to get ideas to paper?

III. Look at the examples of line styles and line thicknesses (line weights) and write the names in the correct places.

dashed line, chain line, thick continuous line, thin line.

1.  _____
2.  _____
3.  _____
4.  _____

IV. Complete the text with the following words: degrees, professional, representation, length, view.

There are several tried and tested 3-dimensional drawing systems used to produce a realistic _____ of an object.

Oblique drawing is the crudest 3-D drawing method but the easiest to master. Oblique is not really a 3-D system but a 2-dimensional _____ of an object with a 'forced depth'.

When using oblique, the side of the object you are looking at is drawn in two dimensions, i.e. flat. The other sides are drawn in at 45 _____ but instead of drawing the sides full size they are only drawn with half the _____, adding an element of realism to the object.

Even with this 'forced depth', oblique drawings look very unconvincing to the eye. For this reason, oblique is rarely used by _____ designers and engineers.

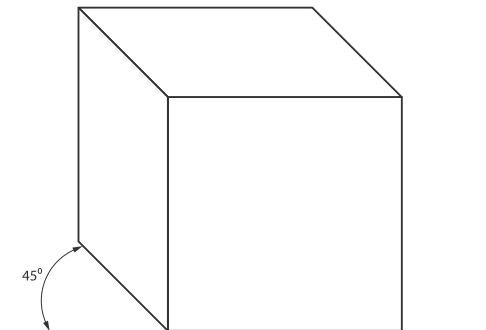

◀ audio ▶

V. Look at the illustration of the isometric drawing and select the correct words in the text.

Isometric is a mathematical method of constructing a *two/three* – dimensional object without using perspective. Isometric was an attempt to make drawings more *artistic/realistic*.

The mathematics involved means that all lengths when drawn at *45/30* degrees can be drawn using their *true/imaginary* length (in other words, lines are not shortened as with oblique drawings).

An isometric drawing shows *two/three* sides of the object and the top or bottom of the object. All vertical lines are drawn *horizontally/vertically*, but all horizontal lines (of the object) are drawn at 30 degrees to the horizontal (line of the drawing). Isometric is an easy method of constructing reasonable 'three-dimensional' images.

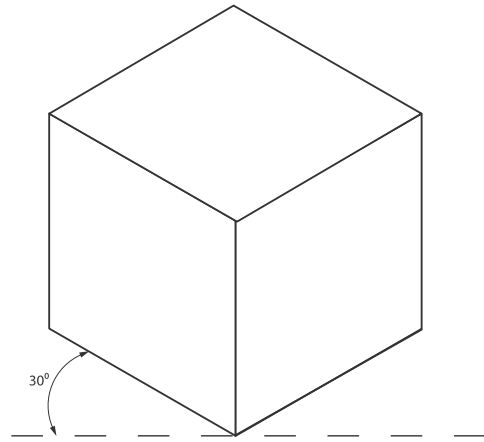

◀ audio ▶

VI. What geometrical figures can you name in English? Make a list.

VII. Write the words in order to create proper sentences.

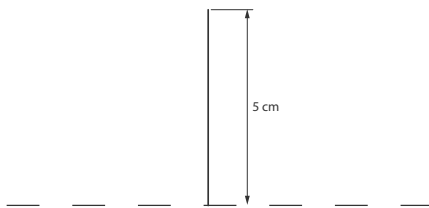

1. Draw edge vertical cube the front of the.

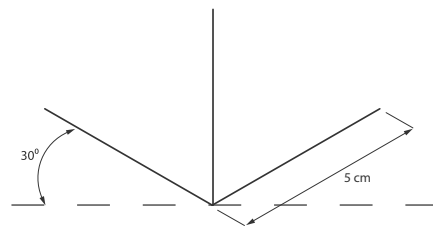

2. The required sides are at drawn in 30 degrees to the horizontal to the length of the box.

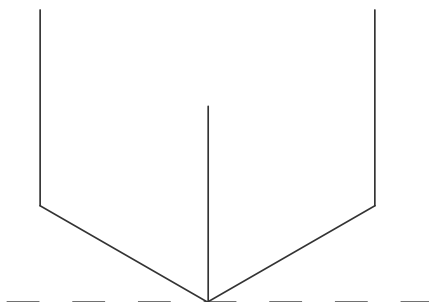

3. Draw back the verticals in.

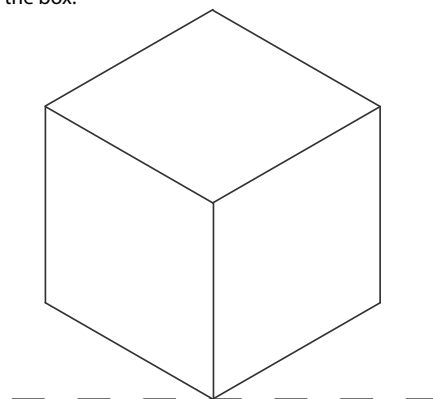

4. Draw in all the lines the top view with drawn to the horizontal at 30 degrees.

VIII. What do you know about axonometric? What can you say about the angle, length of the sides and view in axonometric?

IX. Cover the text below the pictures and say how to draw a cube in oblique and isometric (ex. IV and VII).

Adobe Photoshop is a graphics editing program. Below there is a list of the Photoshop tools – match them with their names: Eyedropper Tool, Brush Tool, Gradient Tool, Crop Tool, Smudge Tool, Sponge Tool, Burn Tool, Paint Bucket Tool, Blur Tool, Pencil Tool.

- _____ – changes the number of pixels in an image by ‘cropping’ away the pixels from the surrounding area.
- _____ – draws free form lines with a hard edge.
- _____ – draws lines with a softer edge.
- _____ – reduces the sharpness (focus) of an image.
- _____ – spreads color in an image, displacing pixels of corresponding colors. It is similar to the effect created by smearing your fingers through wet paint.
- _____ – lightens a part of an image, if the cursor is dragged across it.
- _____ – darkens a part of an image.
- _____ – affects the saturation and contrast of an image.
- _____ – is used to fill a selected area with a color or pattern by clicking on a pixel in that area.
- _____ – is used to sample a color from an image to use this color further.
- _____ – is used to fill with a gradient, i.e. it fills with one color that gradually changes to another.

Read to each other how some of the tools work and try to guess the names.

Then decide on the correct order of the steps below explaining how to make a gradient fill:

- _____ Choose the Gradient tool from the Toolbar.
- _____ Press the left mouse button, and while keeping it pressed, move in a straight line.
The starting point defines where the primary color will begin, the ending point defines where the background color will be. The length of the line determines the degree of transition from one color to another: the shorter the line, the sharper the transition between colors.
- _____ Set the primary color (the first color of the gradient) and the background color (the last color of the gradient).
- _____ Select an area to be filled with a gradient. If an entire layer will be filled then it is not necessary to make a selection.
- _____ Move the cursor inside the selected area.
- _____ Set the tool's parameters in the Options Panel.



The exercises must be done on the basis of the film dialogues.

I. Watch the film and then select the correct answer:

1. The first sketches should capture:

- a) general perspective and proportions
- b) general renderings
- c) as many details as possible

2. Gradations are added:

- a) with a mechanical pencil
- b) with a marker
- c) with coloured pencils

3. Photoshop makes it possible to:

- a) erase pencil lines
- b) finish up details
- c) enhance saturation

II. Listen to the film dialogue carefully and circle the words that you hear:

Bristol paper
tinted paper
linework
shoulder
fineliner
contaminate
oblique
silhouette
view
bucket
highlights
eyedropper
verticals
degrees

III. Decide if the following sentences are true or false:

1. The way to unwind is drawing small objects.
2. In the creative crisis, change of computer programme may help.
3. Black is added to mark metal parts.
4. The material of the body is contrasted with the glass surface.
5. Photoshop can do everything.

I. Answer the questions:

1. What kinds of perspective systems do you know?
2. Who developed perspective?
3. Which kind of perspective is most often used by designers?

II. Read the text and complete it with the missing words. The first letter is given:

All objects we look at have perspective. Objects closer to us are b_____ than objects further away. In other words, as objects get further away, they seem to 'vanish into the d_____'.
 The ability to produce good sketches with convincing perspective is an important s_____ to master helping you to visualise your ideas. There are many ways to g_____ these skills. Practicing drawing objects can help you see how perspective works and will help you with f_____ sketches.

The perspective systems allow you to construct an object using a r_____.

**III. Select the true statement in the information about one-point perspective.**

Using one-point perspective, *parallel/perpendicular* lines converge to one point somewhere in the distance. This point is called the *converging/vanishing* point. This gives objects an impression of *depth/death*.

When drawing using one-point perspective, all objects vanish to one common point somewhere on the *background/horizon*.

The sides of an object *diminish/enlarge* towards the vanishing point.

All vertical and horizontal lines are drawn with no perspective, i.e. face on.

The use of one-point perspective is limited, because the main problem is that the perspective makes small products look *bigger/smaller* than they actually are. One area where one-point perspective can be quite useful is for *drawing details of a designed product/sketching room layouts*.

IV. Write the sentences in the correct order and then make four sketches of the successive stages of drawing a cube in one-point perspective.

- _____ – Draw four lines, one from each corner of the square, which also pass through the vanishing point.
- _____ – Draw a square somewhere beneath the horizon. This will be the front of your box.
- _____ – To complete the box, draw in the back vertical and horizontal.
- _____ – Draw a horizon and place a vanishing point (VP) somewhere on this line.

V. What do you know about two-point perspective? Answer the questions:

1. Which drawing system is more useful – one-point perspective or two-point perspective? Why?
2. How many vanishing points does two-point perspective have?
3. Which lines are shortened – vertical or horizontal?

Write the sentences below in the correct order and then sketch a cube in two-point perspective.

- _____ – Draw in the front vertical of the box. Drawing the line below the horizontal will create a view which we are looking down at. To look at the object from below, draw the front vertical above the horizontal.
- _____ – To complete both of the sides, draw in the back verticals.
- _____ – Draw lines from the top of the vertical which disappear back to both of the vanishing points. Repeat the process for the bottom of the line.
- _____ – Put two vanishing points at opposite ends of the horizontal line.
- _____ – To draw the top of the box, draw lines from the back verticals to the opposite vanishing points.

VI. Look at the picture and then select the correct phrases in the text.

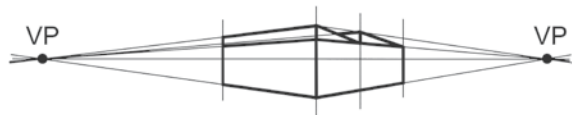
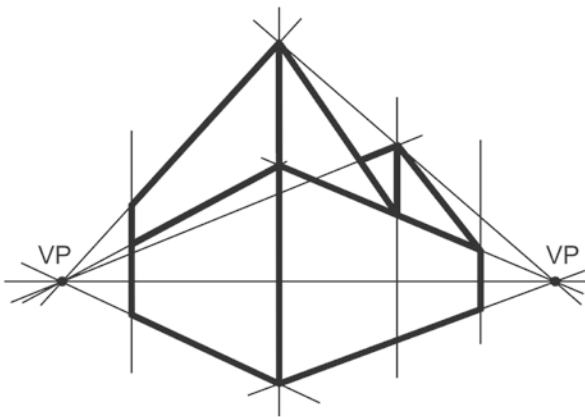

By altering the proximity (= changing the distance) of the vanishing points to the object, you can make the object look big or small. If you draw the vanishing points *close to/far* away from the object, the object *looks small/big*.



VII. Listen to a car designer explaining one step of drawing a car and fill in the blanks:

The linework (...) took less than two minutes and is intentionally _____ just to lay in general perspective and proportion. Make sure the linework is _____ on the paper so that you can _____ most of it later.

Be spontaneous! Listen to good music, that always helps me. If you are getting stuck for ideas, it helps to _____ an element of the process – maybe sketch with a different _____, try a completely different perspective, different paper, or even go to a different location and sketch. If you do the same thing repeatedly, your mind sometimes learns the process too well and things become _____ – new designs won't come to you unless you throw your _____ something new to deal with. This is just my _____, but it seems to work for me. If you are drawing the same car over and over again, _____ and move to a different company!

Before reading the text, check the meaning of the following words: *applicable, walk-through, tactile, to grasp, empathetic, ultimately.*

1. Computer-aided design (CAD) systems are used for constructing architectural drawings, as well as developing ideas within a design process. The scope and purposes of CAD are important not just for drafting ideas, but also for developing and modelling them. (...)

Designers employ CAD systems for a number of reasons. CAD is able to create, manipulate, analyse and represent design possibilities. Computers can carry out rapid and complex calculations, process information and data and help to analyse design in terms of economic, functional and environmental requirements. Drawing on a computer saves time and allows quick access to revise design changes when necessary. Moreover, the computer allows the designer to employ a different set of skills more closely linked to the process of simulation, generating a greater degree of realism. Walk-throughs and movement simulations allow designers to experience and visualize the significance of their designs, as well as communicate these qualities to others.

2. During the design process, there are several benefits to making a physical model over a digital model. Physical models let you experience [the design] as a three-dimensional material object, allowing the design to be understood simultaneously through all of its parts and as a whole. There is tactile immediacy to grasping and understanding the form visually and the composition through movement and rotation. This process compels the designer to be empathetic to the force of gravity and encourages him to think of the material connections. (...)

3. While a digital model also allows a type of visual immediacy through the rapid selection of views, these views are ultimately limited by the screen size and the limitations of the software interface. The designer needs to input a command using the keyboard or mouse in order to rotate, move or modify the image. (...)

Answer the following questions:

1. What are the functions of CAD systems?
2. Why do designers employ them?
3. What are the advantages of drawing on a computer?
4. What are the benefits to making a physical model?
5. What are the limitations of digital drawings?

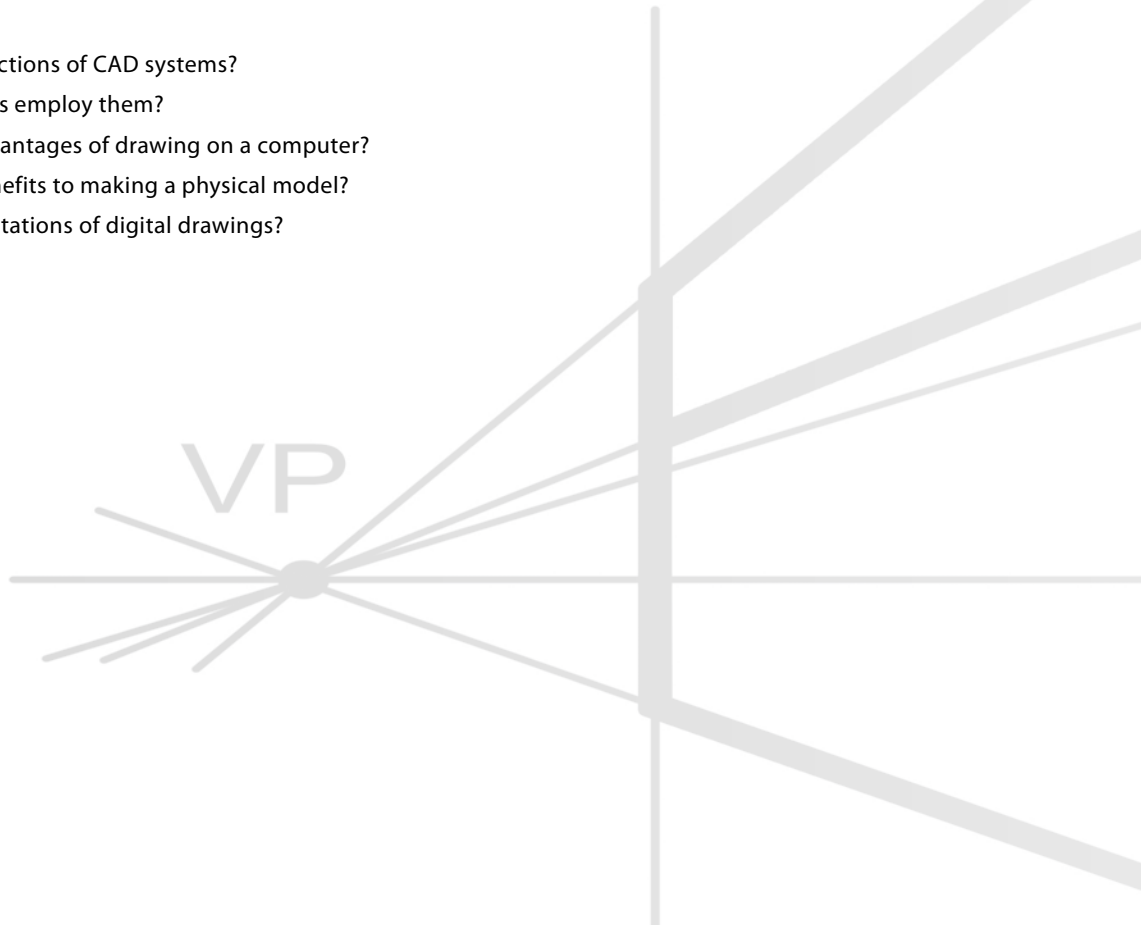



The exercises must be done on the basis of the film dialogues.

I. Watch the film and then select the correct answer:

1. The final critique requires:

- a) different proportions
- b) full freehand drawings
- c) full renderings in Photoshop

2. What is the name of the last method of visualization of a concept?

- a) ER
- b) AR
- c) AY

3. The recent invention is used in:

- a) tourism
- b) optics
- c) fabrication

II. Listen to the film dialogue carefully and circle the words that you hear:

freehand drawings
depth
critique
layout
print-outs
renderings
proximity
vanishing points
environmentally-friendly
convincing
showcase
real-life
framework
augmented
live-view
digital mock-ups

III. Decide if the following sentences are true or false:

1. Concept sketches are important because in the future Grzegorz may decide to use them.
2. He always prints his sketches at the end of the semester.
3. Decision-makers in companies are influenced by 3-D renderings of designed products.
4. All students learn to prepare presentations in Showcase.
5. The newest technique mixes real environment with computer-generated images.

I. *Dimensioning, tolerancing, sectioning, hatching, lettering* – these are several notions connected with engineering drawing. Write the term next to its definition.

1. _____ – to mark or shade with two or more sets of parallel lines.
2. _____ – letters inscribed on an engineering drawing.
3. _____ – the permissible deviation from a specified dimension.
4. _____ – to shade or crosshatch (part of a drawing) to indicate sections.
5. _____ – to indicate the dimensions of (as on a drawing).

II. Below there is an example of an annotated dimensioned drawing. Write the names of its parts in the proper places: *short extension, projection line, small space*.

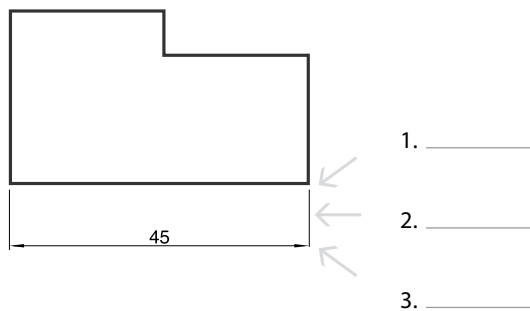

III. Read the text and complete the blank spaces. Use the information from ex. 1 and your own brains.

Dimensions are always drawn using _____ thin lines. Two _____ lines indicate where the dimension starts and finishes. They do not touch the object and are drawn _____ to the element you are dimensioning. In general, units can be _____ from dimensions if a statement of the units is included on your drawing. The general convention is to dimension in _____.



IV. Check the meaning of the words: *coordinates, superimposed*. Then match the names of types of dimensioning with their examples: *Dimensioning by Coordinates, Superimposed Running Dimensions, Chain Dimensioning, Dimensioning Small Features, Parallel Dimensioning*.

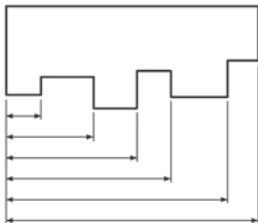

1. _____

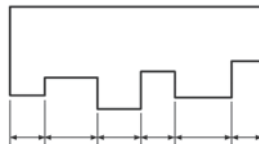

2. _____

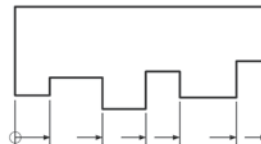

3. _____

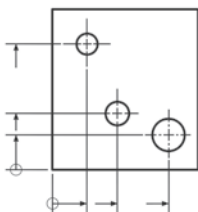

4. _____



5. _____

V. All engineering drawings should feature an information box. An example is shown below.

Decide which section of the box contains the following information:

Company name, Scale, Title, Date, Version, Signature, Name, Checked.

1)	WHEEL BEARING		
2)	John Smith	5)	Tim MacCarthy
3)	1.1	6)	19. 07. 2008
NO NEED TO MEASURE. ALL MEASUREMENTS IN MM'S		7)	1:1
4)	"DESIGN WORLD"	8)	<i>John Smith</i>

Discuss with your partner why all these parts are required in the information box on the engineering drawing.

VI. Identify the types of sectional views: *sectional view in a single plane, sectional view in two planes, part sectional view, half sectional view.*

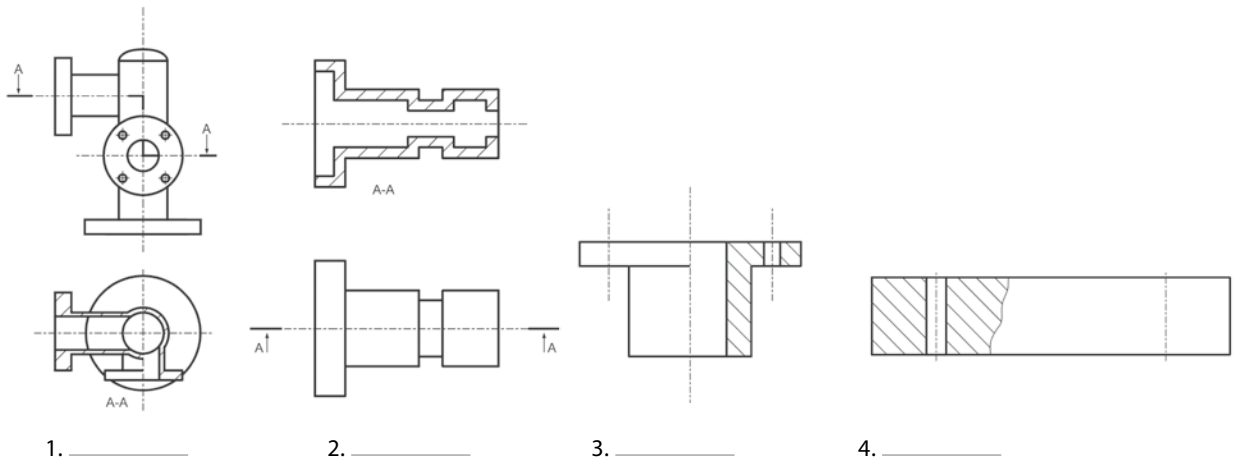

VII. Identify the types of hatching: *hatching, staggered hatching, reversed hatching, cross-hatching.*

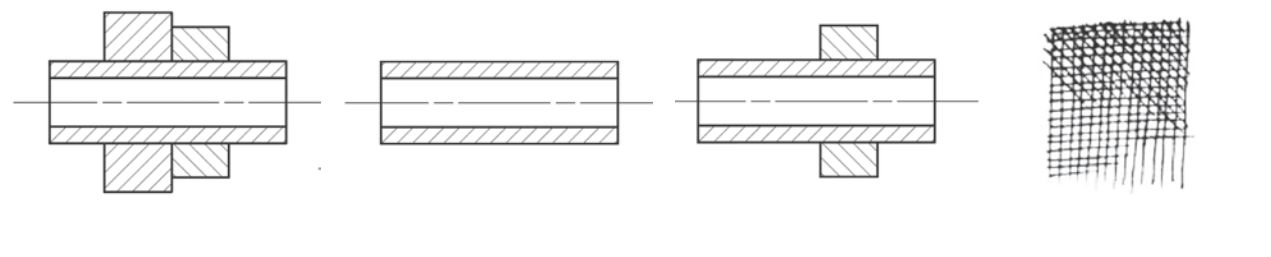

Do you know which of them are used on an engineering drawing and when?

You are going to read a text about a design project.

Match the subtitles below to the paragraphs of the text: *Presentation perspective, Brainstorming, Communicating the concept, Floor plan, Preliminary sketch.*

The Brief: Redesign an existing space to accommodate a modern Italian restaurant for 48 diners.

Budget: Good to moderate.

STAGE 1 _____

At the preliminary meeting the design team was able to draw inspiration from the client's passion for food and generate the initial concept ideas. The approach to the brief was kept simple. Signature dishes from the menu were used as inspiration. (...) By transposing these qualities into words, the team were able to inspire interior ideas and images based around the theme of 'modern rustic'.

STAGE 2 _____

The designer collected images that represented the key words, and a concept board was presented to the client to help visualize the potential scheme by suggesting materials, physical relationships, spatial qualities and atmosphere. A key design consideration was that the interior should complement the food without being too prominent. This means that subtle material contrasts need to be achieved using natural materials such as slate and stone for practical areas and wood for dining areas. The interior can then be further controlled by the use of ambient lighting.

STAGE 3 _____

Different drawings can help identify the different stages of a design process. Freehand drawings are usually used at the start of the project for a 'pitch presentation' to the client. At this stage the designer is not paid and so works quickly to win the sale. (...)

STAGE 4 _____

There is no doubt that a real-life depiction of the scheme helps clinch the deal between designer and client. Every client wants to know what they're getting, and a presentation drawing strives to seduce them by communicating the look of the final design. Unlike the sketch perspective, it is rendered to scale and provides more substantial information about the design scheme.

STAGE 5 _____

In any project it is the most important drawing. It shows the complete layout of the scheme, including the position of furniture, entrances, exits, light sources and circulation areas. A restaurant is a functional environment, and the design should not lose sight of these practicalities.

Though minor changes might occur, this stage usually signifies an agreement has been reached between client and designer with regard to the final design.



The exercises must be done on the basis of the film dialogues.

I. Watch the film and then select the correct answer:

1. Tomasz is going on exchange to:

- a) Great Britain
- b) Holland
- c) Canada

2. Designer's tools include:

- a) spraying fix
- b) triangular scale
- c) easels

3. To make a model, students need:

- a) a tube
- b) a utility knife
- c) an erasing shield

II. Listen to the film dialogue carefully and circle the words that you hear:

- easel
- drawing pad
- dimensions
- projections
- kneaded eraser
- charcoal
- edge
- compass
- tracing paper
- hatching
- Bristol board
- mounts
- clip-frames
- technical pen



III. Decide if the following sentences are true or false:

1. The pages of a sketchbook are bound at the shorter side.
2. Craft paper is grey.
3. If paper has tooth it means the design features the shapes of teeth.
4. Vellum paper is not opaque.
5. A portfolio is used for carrying drawings and paintings.

I. Make a list of industrial products that are made from metal. Play the chain game.

II. Read the text and write the number of the sentence or phrase next to the advantage or disadvantage that it refers to.

All cast irons consist of more than 2% carbon. This high carbon content makes them 1) **excellent materials to use for casting** and at much lower temperatures than those required to cast steel. They 2) **fill the mould more easily when molten**. Grey cast iron, commonly used in engineering, 3) **can break easily** and 4) **cannot be drawn out to be very thin**. It can be machined reasonably easily but 5) **cannot be welded easily**. Cast iron has been used for many applications, such as engine blocks and gears. 6) **Cast iron does not rust easily**.

Advantages

- Better corrosion resistance than steels in most environments
- Has better flow characteristics
- Very easy to cast

Disadvantages

- Very brittle
- Poor weldability
- Not very ductile



III. Listen to the text and fill in the blanks.

Steel in one form or another is the most widely used material for engineering _____. Steel is an alloy of iron and carbon, with the proportion of carbon having a large influence on the _____ of the steel. The carbon content of steel can be anything from 0.08% to _____. There are a large number of different steel alloys available. Two main _____ of steels are: **carbon (mild) steel** and stainless steel. Carbon steel is sometimes referred to as 'mild steel' or 'plain carbon steel'. The American Iron and Steel Institute defines a carbon steel as having no more than 2 % carbon and no other _____ alloying element. Carbon steel makes up the largest part of steel production and is used in a vast _____ of applications.

IV. Now read about mild steels and write the advantages and disadvantages yourself. Use the information about cast iron as a guide.

Typically carbon steels are 1) **stiff** and strong. They are 2) **affordable materials**. They also 3) **exhibit ferromagnetism**. This means they are extensively used in motors and electrical appliances. 4) **Welding carbon steel presents far fewer problems than welding stainless steels**. 5) **Carbon steels rust** and so they should not be used in a corrosive environment unless some form of protective coating is used.

Advantages

- 1) High s _____
- 2) C _____
- 3) M _____
- 4) Easy w _____

Disadvantages

- 5) Poor c _____ r _____

V. Fill in the blanks. The first letter is given.

Stainless steel is steel a _____ with chromium and other possible elements. A stainless steel has a minimum of 10.5 % chromium c _____.

Stainless steel's corrosion resistance is only effective in oxidising e _____s. When exposed to a _____s, the corrosion resistance of stainless steel is no better than that of m _____ steel. Although stainless steel's resistance to atmospheric corrosion is excellent, the presence of chlorides (e.g. in a seaside atmosphere or in s _____ water) can cause pitting to occur.

VI. Choose the correct word.

Titanium is a relatively *scarce/abundant* metal in nature, however, the processes required to *extrude/extract* it are complex and expensive. Titanium can be used as either the *pure/clean* metal or alloyed with other metals such as tin, chromium, copper, etc.

Titanium is used in situations where its *light/low* weight and/or corrosion resistance properties are important. Titanium weighs about half as much *that/as* steel, however, its mechanical properties are better than many steels. It is also much *more stiffer/stiffer* than other lightweight materials such as *aluminium/iron* and magnesium.

Corrosion resistance properties of titanium and its alloys are generally excellent. Titanium's resistance to seawater and other chloride-based *pollutions/solutions* is very good. Generally, titanium is more corrosion resistant than stainless steel.

Working with titanium can *present/represent* problems. Milling and drilling of titanium *revolves/requires* special care to be taken and the cutting tool has to be kept sharp. Welding titanium cannot be carried *out/over* in air, it must be done using TIG welding because molten titanium reacts with oxygen, nitrogen and hydrogen causing the metal to become more brittle. *Casing/casting* titanium requires the use of a special *vacuum/vanity* furnace to ensure that the molten metal does not react with the atmosphere. It is used for applications such as aircraft components and storage tanks for corrosive chemicals.

VII. Find the names of 9 metals in the word snake:

b r a s s g o l d c o p p e r m a g n e s i u m s i l v e r t i t a n i u m t i n s t e e l z i n c



Before reading, check the meaning of the following words: *retail branding, array, fragile, sturdy.*

Fabrics are extremely important when it comes to defining the character of an interior scheme. They can be used to highlight and accent the qualities of a given space in order to enhance a company's corporate identity, give character to retail branding, or simply add comfort and harmony to the home. With such an extensive range of fibres, styles and colours, a designer can find an array of fabric choices. Strongly linked to fashion, manufacturers are constantly updating ranges and launching new series and styles. (...)

Cotton, silk and wool are all associated with subdued colours and delicate natural finishes, providing an informal appearance for a variety of interiors.

Natural fabrics are pleasing, because they appear raw, unrefined and formal in their material qualities. Technology has developed fibre mixes that produce more durable textiles for the home in a wide range of weights and finishes. Fibre mixes have transformed textiles, changing cotton into linen, denim, muslin or chenille, and wool into tweed or cashmere. Silk is luxurious to touch, but is also the most fragile. Mixing silk with cotton offers greater durability.

While irregularities in natural fibres are part of their richness, fabrics made from mixes of man-made and natural fibres are generally sturdier and more durable than fabrics made from natural fibres alone, and can be more cost-effective. When buying patterned or repeated textiles, designers should obtain a good-sized sample to view before buying a larger amount. The standard widths of natural fabrics depend upon the manufacturer.

Surface textures can vary according to the fibre and weave. Mixtures of either natural or synthetic fibres are generally used within the residential sector and in commercial design for upholstery and curtains, soft furnishing and screens.

Answer the following questions:

1. What are the functions of fabrics in interior schemes?
2. What is the launch of new fabric series linked to?
3. What kinds of fabrics are associated with subdued colours?
4. Why are new mixes developed?
5. What are the advantages of new mixes?
6. What are the uses of fibres in interior design?



The exercises must be done on the basis of the film dialogues.

I. Watch the film and then select the correct answer:

1. Tomasz wants to visit the Wrocław Technology Park because:

- a) he wants to pick up a metal element there
- b) he wants to take a metal element there
- c) he wants to cut a metal element there

2. The computer adjusts the bending parameters such as:

- a) weight
- b) thickness
- c) quality of the metal sheet

3. Except from metals, another material that is cut by the water-jet cutter is:

- a) glass
- b) plastic
- c) textile

II. Listen to the film dialogue carefully and circle the words that you hear:

facilities
machinability
state-of-the-art equipment
hydraulic bending machine
acid resistant
cast iron
parameters
represent
titanium
water-jet cutting machine
corrosion resistance
miters
nitrogen
vacuum

III. Decide if the following sentences are true or false on the basis of what you hear:

1. The students want to take part in a joint competition.
2. The digitally-controlled machines can work only one kind of metal.
3. The bent element can be 6 or 8 mm thick.
4. Water-jet cutting means cutting with a stream of water.
5. 35 degree miters can be cut in the workshop.

I. Answer the questions:

1. What are plastics?
2. Do plastics occur in nature?
3. When were they invented?
4. Are they cheap materials?
5. What are the advantages of using plastics in industrial design?

Read the text on page 89 and check if your answers were correct.



II. There are two main families of plastics, thermosets and thermoplastics. Match the name with its definition.

- _____ – become soft when heated. They can be easily moulded and remoulded without significant degrading.
 _____ – are rigid plastics, more resistant to higher temperatures. Once set, they cannot be remoulded.

III. Fill in the words: *exposed, springs, stable, rigid, showerheads, transparent, clear, strengthen, vacuum forming, moisture, tube, equipment.*

Examples of thermoplastics:

- **Acrylics** are available in a range of colours and can be opaque, translucent or _____. They are available in sheet, rod and _____ for use in injection moulding, extrusion and _____. Acrylics withstand weather and are _____ in sunlight. Almost any colour can be produced. Transparent acrylics can be as _____ as the finest optical glass, this led them to be used in optical _____ such as cameras. It is possible to significantly _____ the acrylic when it is being made, these high-grade acrylics are used for aircraft windows.
- **Acetal resins** are strong, _____ and have good _____, heat, and solvent resistance. These engineering resins require stabilisers to be added if they are intended to be used for applications _____ to weathering. They are used for a range of applications, from handles and _____ to industrial applications such as gears and _____.



IV. Listen to the text and fill in the missing words.

Thermosetting plastics are rigid plastics, more resistant to higher temperatures than thermoplastics. Once set, thermosets cannot be remoulded. There are several common thermosetting plastics, for example:

- **Epoxies** come in _____ form and are cured and set after which they cannot be _____. The agent added to the resin to cause it to start and cure (go hard) can _____ the properties of the plastic considerably. Epoxies have excellent chemical _____ and are hard, rigid and sometimes _____. They have excellent _____ properties and are therefore used as adhesives.
- **Polyesters** are hard and brittle but they can be combined with _____ to produce a glass-reinforced plastic (GRP) which is used for car bodies, sailing boats and _____. GRP's can be used for _____ purposes but they are very expensive. They are available in flexible rolls that harden when a catalyst is added to produce a strong rigid _____.

V. Read the text about the linguistic aspect of the term 'plastic' and choose the correct word.

The word 'plastic' is derived *of/from* the Greek/Chinese πλαστικός (plastikos) meaning *capable/incapable* of being shaped or molded (...). It refers to malleability, or plasticity of plastic materials during *fabrication/manufacture*, that allows them to be cast, pressed, or extruded into a variety of shapes – such as films, fibers, plates, tubes, bottles, boxes, and much more.

The common word 'plastic' should not be confused with the technical *adverb/adjective* 'plastic', which is *applied/replied* to any material which undergoes a permanent change of shape (*plastic deformation/saturation*) when strained beyond a certain point. Aluminum which is stamped or forged, for instance, *performs/exhibits* plasticity in this sense, but is not plastic in the common sense. In contrast, in their finished forms, some plastics will *break/brittle* before deforming and therefore are not plastic in the technical sense.

◀ audio ▶

VI. What do the abbreviations stand for? The first ten are kinds of plastics, can you give examples of their uses?

- | | |
|-----------|-----------|
| 1. PP – | 9. PC – |
| 2. PS – | 10. ABS – |
| 3. HIPS – | 11. CAD – |
| 4. PET – | 12. CAM – |
| 5. PES – | 13. GRP – |
| 6. PA – | 14. CNC – |
| 7. PVC – | 15. SLS – |
| 8. PU – | 16. FDM – |

Listen and repeat the names of plastics. Mark the stress.

VII. Read the text and complete it with the following words: *quality, functional, desirability*.

Planned obsolescence means intentionally limiting the life of products so that consumers are manipulated into consuming more. There are three types of planned obsolescence:

- _____ obsolescence – when a new product appears to do a better job than its predecessors.
- obsolescence of _____ – which is related to the physical durability (building in key components that fail after a given amount of time).
- the obsolescence of _____ – which is connected with changes in the appearance, fashion and consumer opinion.

The worst effect of planned obsolescence are disposable products.

Give examples of disposable products commonly used nowadays. Bring an example for the next class – if it is made from plastic, find out what kind it is.

Read the text and decide if the sentences below are true or false:

Copper is a reddish brown metal widely used for applications which benefit from its excellent electrical conductivity. Copper can easily be shaped but its lack of strength stops it from being used for structural engineering applications. Copper can be easily soldered or brazed.

Brass is an alloy of copper and zinc. It is harder than copper and it is a yellowish colour but its surface tarnishes very quickly. Brass can be easily cast and machined and is mainly used for electrical fittings and ornaments.

Magnesium is a fairly abundant metal in nature, however, extracting it requires the use of an expensive electrolysis process.

The main advantage of magnesium is that it is one of the lightest engineering metals available. Because of the relatively low tensile strength of pure magnesium, it is usually used as an alloy (usually with aluminium, manganese and zinc). Because of its light weight, it has applications in the aircraft and aerospace industries. However, the use of magnesium is limited because the strength of aluminium is similar and typically costs half as much. Magnesium is also more brittle than most aluminium alloys.

Magnesium's corrosion resistance is reasonable. Its corrosion resistance is not as good as aluminium. Exposure to salt water or seaside atmospheres can cause rapid pitting. The machinability of magnesium is excellent.

1. One of the main uses of copper is electrical wiring.
2. Copper is ductile.
3. Copper can be joined using molten metal.
4. Brass is an element.
5. Its surface changes colour in atmosphere.
6. Magnesium is a scarce metal.
7. Aluminium is more expensive than magnesium.
8. Magnesium corrodes fast in salt water.
9. It is easy to be cut with a cutting tool.

Before reading the text, check the following words:

rotation moulding, embark on, filament, bond, scribble.

Tom Dixon's success with rotation moulding encouraged him to embark on more radical experiments with plastic in 2001. Plastic extrusion machines generally inject molten plastic directly into a mould. Dixon's innovation was to omit the mould and form objects directly from the filament of plastic as it emerged from the nozzle of the machine, rather like icing a cake. He settled on Provista Copolymer, a resin made by Eastman with a very clear, glass-like quality, high strength and a glossy surface. There was no limit to the size of the object that could be formed, because there were no moulds. The only constraint was the speed at which the plastic thread could be positioned as it hardened and would also bond on contact. In this respect the analogy of blowing glass by hand is useful as hot glass performs in much the same way as molten plastic. The chairs, tables, large bowls and other objects that Dixon called the 'Fresh Fat' collection were like three-dimensional scribbles, dynamically capturing the fluidity of the material at the moment it was extruded.

Answer the questions:

1. What was Dixon's invention when he started to experiment with plastic?
2. How is the technique compared?
3. Why did he settle on Provista Copolymer?
4. Why could objects of any size be made?
5. What was the limitation?
6. How are the objects from the 'Fresh Fat' collection described?



The exercises must be done on the basis of the film dialogues.

I. Watch the film and then select the correct answer:

1. The students might be interested in the offer of the company which is called:

- a) rapid prototyping
- b) e-prototyping
- c) fast-prototyping

2. The FDM technology can be compared to:

- a) two-dimensional printing
- b) three-dimensional printing
- c) printing new dimensions

3. The company makes models:

- a) only from plastic
- b) only from glass
- c) from diverse materials

II. Listen to the film dialogue carefully and circle the words that you hear:

selective laser sintering
 polyamides
 polystyrenes
 acetal resins
 batch
 rolls
 injection moulding
 rotation moulding
 manufacturing dies
 endurance tests
 catalyst
 medical applications
 hard-machinable
 composites

III. Decide if the following sentences are true or false:

1. The SLS technique makes models from thermoplastic and thermosetting materials.
2. The new technologies open three dimensions for a designer.
3. The rapid prototyping makes only small batches of models.
4. CNC allows one to produce prototypes from different metals.
5. It is not possible for the students to visit the company.

I. Read the text and answer the questions below. Do not read parts of the text but try to give the answers in your own words.

The way in which a product is made has a big effect on decisions taken by the designer during the design phase, after all it is important that the product can be made. It is vitally important, therefore, that the correct manufacturing processes are chosen at the design stage so that your design doesn't have to be changed later. Obviously in industry, the aim is to produce a design which requires as little change as possible when being made, because change costs time, and time costs money! In some engineering sectors you may design something in the morning, it will be made in the afternoon and reach the customer the next day!

1. Why should the designer consider the way a product is made?
2. Why is it undesirable for a design to be altered after the design stage?
3. Which product do you think can have a 24-hour lead time?



II. Read the text below and complete it with the appropriate form of the verb in brackets. Sometimes a word does not change.

Casting is a process in which (melt) _____ material is (pour) _____ into a mould of the (require) _____ shape and then allowed to (solidify) _____. **Moulding** is a similar process used to (form) _____ plastic materials. The mould should be (shape) _____ so that molten material (flow) _____ to all parts of the mould.

III. Work in groups of three. Each student should read about one casting technique and fill in the table with a short note about the following factors:

	sand casting	die casting	investment casting
THE NUMBER OF CASTINGS			
THE COST PER CASTING			
THE MATERIAL BEING CAST			
THE SURFACE FINISH AND TOLERANCES OF THE FINISHED CASTING			
THE SIZE OF THE CASTING			
OTHER			

Sand casting

This involves packing a moulding material (traditionally a mixture of sand and clay) around a pattern of the casting. This is usually made of a hardwood and will be larger than the requirements of the finished casting to allow for shrinkage. The mould is then split so that the pattern can be removed.

Advantages

This process can be used for a large range of sizes and for small or large production runs. It is the cheapest casting process available for small production runs and can sometimes be economical for large production runs.

Disadvantages

The surface finish and tolerances of the finished casting are poor. This form of casting can significantly alter the mechanical properties of the material being cast. The time required to cast components can be excessive due to the need to allow the casting to cool before removing it from the mould.

Die casting

Die casting uses a metal mould into which molten metal is poured and allowed to solidify. There are two main methods of feeding the molten metal into the mould. Gravity die casting uses the force of gravity to draw the molten metal down into the mould. Pressure die casting involves forcing the molten metal into the mould under pressure. Using pressure die casting enables more complex shapes to be cast ensuring the molten metal flows to all corners of the mould.

Advantages

- Machining and finishing costs can be significantly reduced or even eliminated because of the relatively good dimensional tolerances and surface finish achieved using this process.
- All casting alters the physical properties of the material, but using die casting this can be minimised.

Disadvantages

- This process is too expensive for small production runs because of the high cost of producing the mould.
- Its use is restricted to metals with lower melting points (e.g. magnesium, aluminium) than the metal of the mould.

Investment casting

This process is sometimes termed lost wax casting. In this process, metal moulds are used to produce wax patterns of the part to be produced. The wax patterns are then coated with a ceramic paste. This is heated and the ceramic hardens to make the mould and the wax melts. Molten metal is then forced into the ceramic mould. When the metal solidifies, the ceramic mould is broken away. This process is typically used for smaller components and it is unlikely that this process would be used to cast components weighing more than about 12 Kg.

Advantages

- This is the only reliable casting process for metals with high melting points.
- The surface finish of the casting can be very good.
- Relatively cheap for small production runs.
- Suitable for casting complex shapes.

Disadvantages

- This process is only really suited for casting small components.
 - It is an expensive process for large production runs.
-

IV. Work in groups of three. Answer your partners' questions concerning the type of casting that you read about so that they can complete the information in their books. Complete your table on the basis of what your partners tell you. Then read the whole text about casting.

Complete the advertisement with the following words: *advances, software, packaging, websites, creativity, experience, designers.*

One of Libya's leading multi-disciplinary practices have openings for talented and enthusiastic graphic _____ that fit the following description: Use knowledge of current graphic design _____ – such as InDesign, CorelDraw, Photoshop, Illustrator – to produce graphic art and visual materials for promotions, advertisements, _____, and informative and instructional material through a variety of media outlets such as _____ and CD-ROMs.

Must remain abreast of technological _____ in the field and be able to identify areas of use in the organization. Familiar with standard concepts, practices and procedures within a particular field. A great deal of _____ is expected. _____ in working within an architectural practice is an advantage.

Great benefits include: flights, accommodation, transport, 30 days annual leave and tax-free salary.

Those who are qualified and would like to apply, you should send your CV and examples of previous work to n.alsaigh@allabina.com. The following information should be included: name, date of birth, place of residence, nationality, year of graduation, name of university/college, specialization... Speaking and writing Arabic is an asset.

Imagine you are at the start of an interview.

Ask your partner questions about the personal details mentioned in the text.

.....

Before reading the text, check the following words:

infancy, prohibitively, interface, corresponding, to fuse, utterly.

As its name suggests, rapid prototyping was developed as a tool for industrial designers and manufacturers to accurately and quickly model components in three dimensions, and in its infancy in the 1990s the technology was prohibitively expensive. Like CNC cutting, rapid prototyping is entirely dependent on the interface of a digital design and a tool. In this instance, the computer-generated designs are 'sliced' virtually into layers as thin as 0.15 mm. Several competing technologies exist to fabricate the objects and one of them, selective laser sintering (SLS) is often described as three-dimensional printing. As thin layers of polyamide powder are laid down on top of each other, computer-controlled laser beams scan the surface corresponding to the layers of the sliced design, and the lasers' heat causes the molecules of the powder to fuse. Over time the three-dimensional object is built up, fused layer by fused layer. (...) A frequently used analogy is that the objects are 'grown' in the rapid prototyping machines, which indeed is how it looks. But the organic metaphor only serves to conceal the utterly digital origins of the technique.

Answer the questions:

1. What was the purpose of developing rapid prototyping?
2. What happens to virtual designs?
3. Which technology is called three-dimensional printing?
4. How are objects build up?
5. What is the technique compared to?



The exercises must be done on the basis of the film dialogues.

I. Watch the film and then select the correct answer:

1. All of the facilities are stored in:

- a) one building
- b) two buildings
- c) three buildings

2. When somebody wants to change the colour of the prototype:

- a) it is possible in several colours:
- b) it is not possible
- c) it is possible to obtain the model in one colour

3. The company makes:

- a) prototypes in a very cheap way
- b) money with the SLS technique
- c) prototypes faster than in the traditional way

II. Listen to the film dialogue carefully and circle the words that you hear:

measurements
tolerances
working principles
deposits
shrinkage
layers
surface
inkjet printer
nozzles
Z-axis
durable
precise
complexity

III. Decide if the following sentences are true or false:

1. The dimensions of the working chamber are 440×440×620.
2. When a model is being made, it is built up from individual layers.
3. The material has to be in liquid form.
4. The properties of the model are similar to the properties of the end object.
5. The relation of cost to time is an advantage of the rapid prototyping techniques.



I. Match the parts of sentences:

- | | |
|--|--|
| <ol style="list-style-type: none"> 1. Fabrication technique involves 2. The material is first cut 3. Then it is joined 4. This process is suitable for small production runs 5. It is not so suitable for large production runs | <ol style="list-style-type: none"> a) because of its labour-intensive nature. b) to the required shape. c) making components up from stock materials. e) using a suitable joining technique. d) because the high initial costs associated with other processes such as casting are avoided. |
|--|--|

II. Student A: do the exercise below. **Student B:** do ex. V.

Read the text below and fill in the table about sawing.

Sawing is a tried and tested fabrication process using saw teeth. In order to minimise material wastage, the saw blade should be as thin as possible. The most common type of saw used is the circular saw, however, other types include hack saws, jig saws, abrasive saws and friction saws. Abrasive saws feature very narrow grinding wheels. Friction saws have fairly blunt teeth. These strike the workpiece at high speed and localised melting occurs due to friction. This type of sawing has the disadvantage of leaving a burred edge to the workpiece. Sawing generally leaves a fairly smooth and clean cut, the cost of equipment is relatively low but it is difficult to cut curved surfaces.

Technique	Cutting tool	Cut material	Advantages	Disadvantages
Sawing				
Flame cutting				

Now cover the text and tell your partner about sawing so that he/she is able to fill in his/her table.

III. Read the text and complete it with the given words: *fastener, thread, friction, safety, jets, fasteners, grouped, heavier, specifying, stud and nut, brass, 'head'*

Bolting is the general name for fastening devices that utilise the screw _____. The discovery of the screw principle is attributed to Archimedes who lived in the 3rd century BC. However, it is uncertain as to when screws were first used.

There are a large number of threaded _____ available on the market but unfortunately many engineers still do not realise the consequences of selecting the wrong _____ for their application. For example, _____ such as the Boeing 747 contain up to 2.5 million. If the designers had selected a wrong fastener it could make the aircraft more expensive and _____. Selecting an incorrect fastener can affect _____ or cost a company far more than it should to make the product. Therefore, it is important that engineers should understand the procedure for _____ fasteners from the choice available.

Types of fasteners

While there are many types of threaded fasteners they can be _____ into four basic families: screws, bolt and nut, _____, and threaded rod and nut. Fasteners today are manufactured mainly from carbon steel and from a variety of other materials including plastics, aluminium, _____, copper, stainless and other alloy steels, etc., and may be coated to reduce thread _____ and wear. To confuse the issues of selection further there are many types of screw and bolt _____, each of which is ideal for a specific fastening operation.

IV. Student A: do the exercise below. **Student B:** do ex. VI.

Read the text below and answer student B's questions.

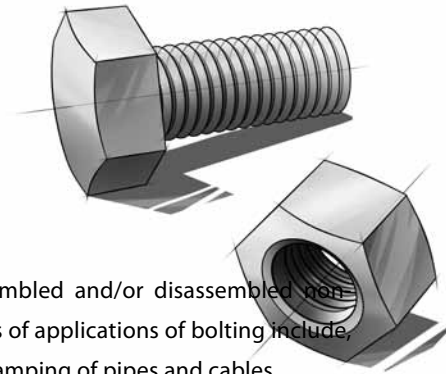

Bolting applications

The prime application of bolting is to provide mechanical connections which can be assembled and/or disassembled non-destructively and which are strong enough to resist the loads placed on them. Typical examples of applications of bolting include, the fixing of car wheels to wheel hubs, the fixing of cylinder heads to cylinder blocks and the clamping of pipes and cables.

Advantages

- Ease of use – i.e. little or no technical expertise needed to assemble/disassemble a bolted connection other than the ability to use a torque wrench where required
- Cheap
- Readily available
- Availability of engineering data, both experimental and of actual usage collated over many years

Disadvantages

- Sometimes bolted joints can loosen when they experience vibration
- Selecting a fastener

Ask student B the following questions about his/her text:

1. Is the choice of screws and bolts always a very important decision for a designer?
2. When can a designer disregard the mechanical properties of screws and bolts?
3. For non-critical bolting, what are the judgement factors?
4. Do designers ever choose larger bolts than necessary?
5. What are the factors determining the choice of bolts when safety is important?
6. Why is it vital to use the smallest possible number of screws and bolts?

V. Student B: read the text below and fill in the table about flame cutting.

Flame cutting process is used to cut ferrous materials. The material is heated by an oxygen - fuel gas flame to a sufficient temperature to cause the steel or iron to oxidise. The oxide slag is then blown from the workpiece by the oxygen stream. This technique uses equipment similar to oxyacetylene welding except that a special cutting nozzle is used on the cutting torch. Oxidation resistant steels (e.g. stainless steels) may be cut by adding iron powder into the oxygen stream. Flame cutting uses standard, readily available equipment but it is not suitable for non-ferrous materials and wastage of material can be a problem.

Technique	Cutting tool	Cut material	Advantages	Disadvantages
Sawing				
Flame cutting				

Now cover the text and tell your partner about flame cutting so that he/she is able to fill in his/her table.

VI. Read the text below and answer student A's questions from ex. III.

In many cases, screws and bolts are selected by designers on an arbitrary basis, for example, they choose a bolt because they have it in stock. This is especially true with non-critical applications whose loads are small – as with the attachment of a car number plate. Here, almost any size would suffice, including sizes considerably smaller than those normally used.

For non-critical bolting, selection is often a matter of judgment based on factors such as cost, ease of handling and assembly, availability, visual appearance, etc. This also often applies where the loads are both significant and known in advance. Here, larger bolts than necessary are sometimes used because smaller bolts 'do not look right' and the cost penalty of using larger bolts may well be minimal.

For industrial uses, for example, where safety is a critical factor, bolt sizes should be calculated or obtained from tables taking into consideration such factors as:

- Size and direction of loads
- Materials of construction
- Ease of assembly and maintenance
- Product life

By standardising on the smallest number possible of different screws and bolts a company can reduce its stock levels and thus add to its ability to compete in the global market.

Ask student A the following questions about his/her text:

1. What is the purpose of bolting?
2. What are the examples of its applications?
3. Is bolting easy to use?
4. Has the technique been researched carefully?
5. Is it expensive and rare?
6. What are the disadvantages?

Now both of you read each other's texts and check if you have understood everything.

Before reading the text, check the following words: *intersection, jobbing, oeuvre, to perch.*

By focusing on what is new, Ron Arad has created a body of work at the intersection of art and design. In so doing, he has changed the way designers perceive themselves. Not content to be either a marginalized designer-maker, or a jobbing product designer working to a company brief, Arad has drawn from both craft and industry to create a unique space where he can create furniture and objects that initially exist to answer his own exploration of materials, techniques and symbolism. (...)

A characteristic of Arad's oeuvre has been to explore a single form in many different media, each with their own qualities, demonstrated by the various versions of the Big Easy chair, an example of which perches on the roof of his studio like a sign representing his activities. He made the first versions himself in 1989, and they bear his raw welds and hammer marks. Later, skilled specialist metal-workers refined the fabrication, and Arad specified a highly polished surface. These metal chairs were still made to order as part of limited editions and were 'sittable sculptures' for collectors as much as they were usable furniture. But Moroso in Italy translated the shape of the steel chair into foam and upholstery in 1990, introducing it to the international market for contemporary furniture that, though small, was still larger than the collectors' or art market.

Answer the questions:

1. Are Ron Arad's works art or design?
2. What is his main reason to create furniture and objects?
3. What is his characteristic feature?
4. What transformations did the Big Easy chair undergo?
5. Which market is bigger than the collectors' market?



The exercises must be done on the basis of the film dialogues.

I. Watch the film and then select the correct answer:

1. The students are going to visit a wood shop:

- a) in a cooperating company
- b) in the Academy
- c) in one of the professors' studio

2. A band saw is used to cut:

- a) big formats
- b) shapes
- c) small formats

3. The component that Tomasz wants to pick up:

- a) can be picked up in the metal shop
- b) has been completed
- c) is not ready yet

II. Listen to the film dialogue carefully and circle the words that you hear:

circular saw
jig saw
chunks
strips
four-blade rip
stair tread
planer
abrasive paper
router
fastener
files
disks
bolts
blades
banisters

III. Decide if the following sentences are true or false:

1. The tutors want the students to get to know machines even if they are not available in the Academy's facilities.
2. A rip cuts bigger pieces into boards.
3. Pieces of wood can be glued together in a very short time.
4. Exotic wood is not worked in the wood shop visited by Zoe and Tomasz.
5. A router is used for giving rounded shape to wood.



I. Read the text and complete it with the given words: *motion, remove, wastage, shape, large, widely, cutter, precision.*

Machining techniques

All machining processes _____ materials to form shapes. As metals are still the most _____ used materials in manufacturing, machining processes are usually used for metals. However, machining can also be used to _____ plastics and other materials which are becoming more widespread. Basically all the different forms of machining involve removing material from a component using a rotating _____. The differences between the various types arise from the relative _____ between cutting tool and workpiece and the type of cutting tool used.

Advantages

- Machining processes allow high _____ components to be rapidly produced.

Disadvantages

- Machining processes are not suitable for removing _____ amounts of material.
- There can be a large amount of _____.

What machining techniques can you name in your language?

II. There are a number of different types of machining operations available to remove material. These include: *milling, grinding, turning and drilling.*

Write the name of the machining technique next to its definition:

	reducing to powder or small fragments by friction
	boring or driving a hole in something
	shaping or dressing by means of a rotary cutter
	shaping or finishing work in a lathe

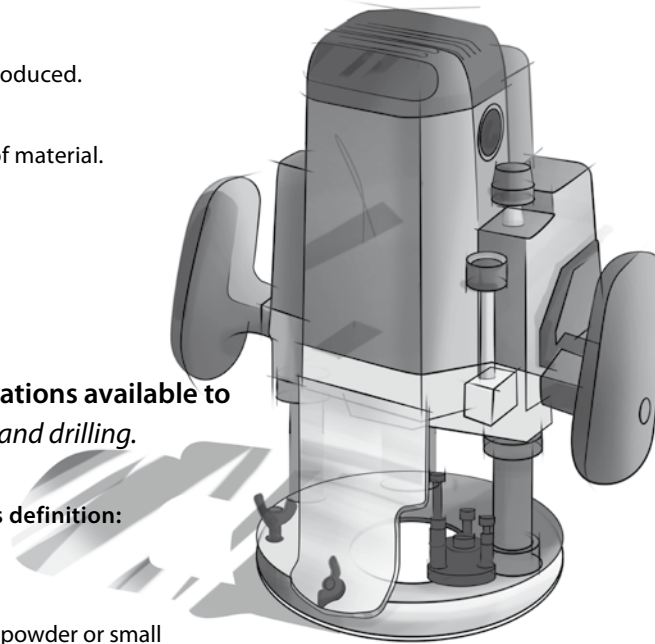

III. Match the plastic forming techniques with their definitions: *extrusion, compression moulding, injection moulding, blow moulding, rotational moulding, thermoforming, foaming.*

- _____ a low-heat, low-pressure process in which a mould is rotated so that the plastic fuses to the interior of the mould to produce hollow objects, e.g. refuse bins.
- _____ a molten polymer is blown into a mould to create a hollow moulding, e.g. plastic bottles.
- _____ the melted material is pushed through the orifice of a die, e.g. film, sheets or tubing.
- _____ plastic pellets are heated and compressed into a mould at the same time.
- _____ a molten resin is shot into a mould under considerable pressure.
- _____ heated sheet of thermoplastic is pulled by a vacuum into a mould, e.g. drinking cups.
- _____ a material with gas bubbles is produced which can be moulded or extruded, e.g. egg cartons and fast-food packaging.

IV. Cleaning a surface prior to the application of a finish is vital to ensure a clean surface for the finish to adhere to. There are a number of different cleaning techniques and processes available. They can be generally classified into mechanical and chemical methods. All have their own advantages and disadvantages.

Look at the cleaning methods and decide whether they are mechanical or chemical:

wire brushing, acid cleaning, tumbling, solvent cleaning, shot blasting, alkali cleaning.

V. Put the letters in order and find out the correct common finishing processes (the first and last letters are correct):

1. P T I N N I A G
2. E L O C T R O P L A I N G
3. H T O I D P T O A C I N G
4. A N D O I S I N G

Now match the process with its definition:

A. This is the most common surface finish applied to any product and the range of different types available is huge. Usually it is applied in at least two coats. A primer layer helps the finish layer adhere to the surface, fills in any minor defects in the surface and imbues the coating with any corrosion resistance. The finish layer then gives the coating its desired aesthetic properties. The surface needs to be relatively grease-free. It is a relatively cheap process but does not usually give a high degree of protection against corrosion, etc.

B. This process can be used to coat a wide variety of plastics and metals. Plastics to be coated must first be coated with an electrically conductive material. The process involves using the workpiece as the cathode in a solution of the metal that will be the coating. By applying a DC current, the metal ions in the solution are deposited on the workpiece surface. Typical metals used are chromium, cadmium, zinc and silver. The surface needs to be carefully cleaned before the process is used.

C. As the name suggests, this process involves dipping the workpiece into a molten metal. This process is most commonly used for coating steel surfaces with zinc (galvanising), however, it can also be used to coat the workpiece with tin, lead or aluminium. Because of the temperatures involved, this process can only be used for metals with high melting temperatures such as steel, cast iron and copper. It gives a uniform deposition of coating.

D. This electrolytic finishing process is applied to aluminium surfaces to provide a corrosion resistant finish. Aluminium naturally has a very thin layer of aluminium oxide on its surface. By using the workpiece as the anode, the thickness of this surface layer is increased. The anodised layer can be coloured by adding dyes to the electrolyte. The surface should be cleaned with alkali prior to the process.

Read the candidate's requirements for a position of a product designer or interior designer and tick the points that would make you a suitable applicant:

product designer

- fluency in English.
- a strong design portfolio in product design.
- significant experience with various fabrication processes.
- strong workshop skills.
- be resourceful and confident in speaking with external suppliers and fabricators.
- solid 2-D/3-D CAD skills.
- experience in architecture, lighting design, electronics or programming would be helpful but is not necessarily required.
- be efficient with their time and be prepared to join an extremely fast-paced environment.

interior designer

- clear sketching skills.
- excellent all round CAD skills including Photoshop and Vectorworks 3-D.
- experience running projects on site from conception to completion.
- collaborative design experience.
- intermediate Microsoft Office/OpenOffice skills.
- experience developing concepts from both open ended briefs to tightly defined briefs.
- excellent communication skills in terms of reading, writing and presentation to clients and suppliers.
- strong work ethic and a great sense of humor!

Before reading the text, check the following words: *ribs, immense, to reap, centrifugal force, to spin.*

Jasper Morrison developed the Air chair (1997-9) with Magis, another Italian plastics specialist, using technology developed in the Automotive industry. The form of the chair, the thickness of the plastic and even the position and direction of the injection points were all calculated in advance by computer simulations. In a single moulding, polypropylene strengthened with glass fibre was injected into the mould, as were precision-calculated chambers of air that gave the chair its name and also its lightness. The air chambers left ribs between them that created the invisible skeleton of the chair. The tooling for such a chair required immense investment, but a successful design reaps rewards for its manufacturer: each Air chair took just four minutes to fabricate (...).

Not all plastic technology requires such high level of tooling and investment. Rotation moulding is simpler and cheaper, and uses centrifugal force to spread polyethylene around the inside of a spinning mould. The results tend to be cruder than injection moulding, often bearing mould marks and with variable thicknesses of plastic, but they are durable and, most importantly, inexpensive.

Answer the questions:

1. What parameters were calculated by computer simulations?
2. How many mouldings were necessary to fabricate Air chair?
3. What was the function of air chambers?
4. Why was it worth investing in expensive tools?
5. What are the advantages of rotation moulding?



The exercises must be done on the basis of the film dialogues.

I. Watch the film and then select the correct answer:

1. In the metal workshop they work with:

- a) stainless steel only
- b) mild steel only
- c) both stainless and mild steel

2. The finishing process:

- a) is done on site by specialists
- b) is done by a cooperating company
- c) is done either on site or by a cooperating company

3. The English names of the finishing touches:

- a) are unknown to Tomasz
- b) were taught during Tomasz's English classes
- c) are provided by Zoe

II. Listen to the film dialogue carefully and circle the words that you hear:

- lathe
- banister
- TIG welding
- grinding
- friction
- shot blasting
- wire brushing
- tumbling
- cutter
- anodizing
- electroplating
- hot dip coating
- conductivity
- laser cutting

III. Decide if the following sentences are true or false:

- 1. The same tools should not be used to for working stainless steel and mild steel.
- 2. Rough ends are evened in a band saw.
- 3. Welding utilizes a tungsten electrode.
- 4. Shot blasting gives the surface of stainless steel a semi-gloss finish.
- 5. Guillotine is a cutting edge technique.

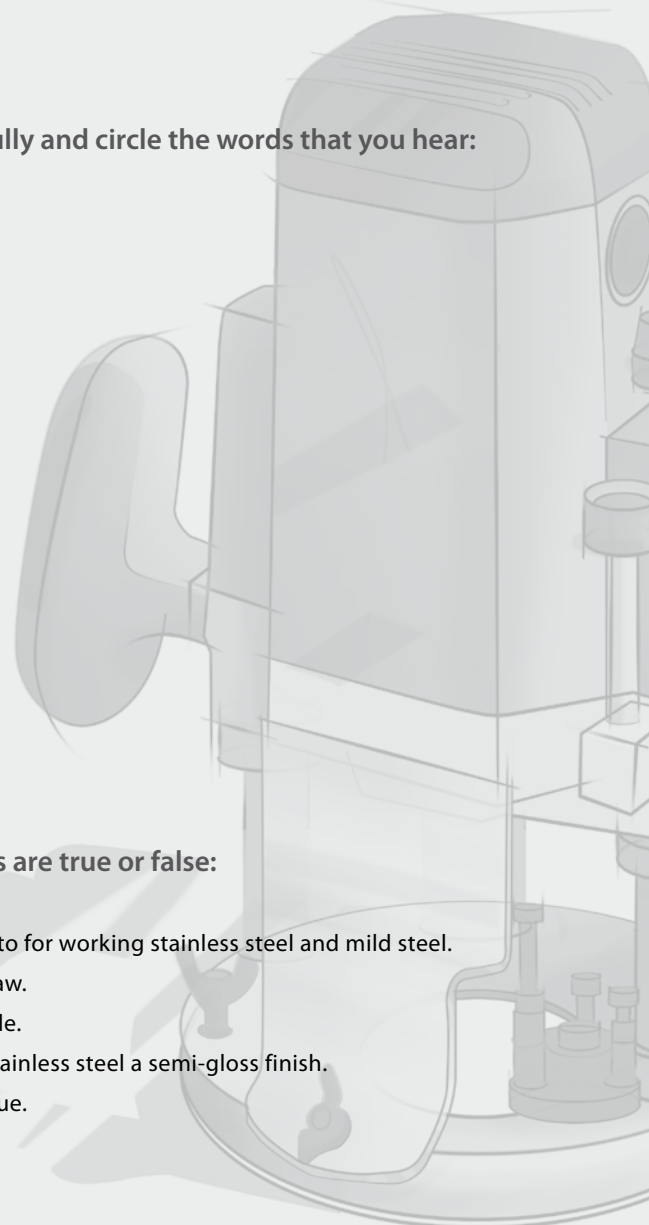

I. When you evaluate a product, what do you take into consideration? Put your answers in order of importance.

II. Student A: read the text below and fill in the table. **Student B:** read the text in ex. IV.

For a firm seeking to start manufacturing a new product at the beginning of the 1990s, the fundamental problems were to choose a product acceptable to the consumer, and to achieve good quality – the technical level of Polish industry at that time deviated greatly from the standards evolved in highly developed countries. (...) The decision was made to launch production of a bread box in 1993.

The bread box was given a rounded, neutral, unobtrusive shape that would not compete with other objects in the kitchen. Its characteristic feature, besides good performance of its function, is ease of assembly and thus ease of cleaning. On the bottom of the container is a grate keeping the bread from touching the plastic – injection-moulded polystyrene – and allowing free circulation of air around the loaf. The clear top entirely covers but gives a view of the contents of the box. These features give the product its hygienic look. The use of low-cost technology permitted large-scale production and low pricing. For all these reasons the product began to sell well in Poland and Eastern Europe.

Item	Material	Year of production	Description	Advantages	Other remarks
Lamela bread box					
Vela 203 portable television					

Now cover the text and tell your partner about the Lamela bread box so that he/she is able to fill in his/her table.



III. Student A : look at the picture of another product on p. 98 and complete the points below.
Student B: do ex. V.

- item: Zefir electric fan
- material: plastic housing
- year of production (guess):
- colours:
- base:
- typography:
- appearance:
- specific use: a decorative little gadget used to prevent shop windows from fogging

Now tell student B as much as you can about the item.

IV. Student B: read the text below and fill in the table.

The idea of a small portable television as a second one for the home was born in the United States in the 1960s. Production of such a television in Poland was undertaken with Western customers in mind.

At this time there were expensive Japanese-made portable televisions on the Polish market (...), so the Vela quickly became an attractive and sought-after product. The most popular one was the Vela 203 (1976), with a black-and-white Polish-made picture tube 31 cm in diameter. It used house current or car batteries. The ABS plastic housing was designed to be as uniform as possible; protruding parts were eliminated, with the handle, antenna, knobs and switches hidden in the housing. Its shape was practically cubic, in line with the aesthetic expectations of consumers in the 1970s, but the slightly rounded corners anticipated approaching changes coinciding with the styling of the next decade, in which sharp corners were replaced by gentle curves and the boxy shape faded from the scene. The housing was made of plastic in several solid light colors: white, orange and yellow.

Item	Material	Year of production	Description	Advantages	Other remarks
Lamela bread box					
Vela 203 portable television					

Now cover the text and tell your partner about the Vela 203 portable television so that he/she is able to fill in his/her table.



V. Student B: look at the picture of another product on p. 99 and complete the points below:

- item: Fala toothbrush
 - material: injection moulded-polystyrene, polyamide fiber brush
 - year of production (guess):
 - colours:
 - head:
 - overall appearance:
 - additional remarks: the customers of this toothbrush are people on a tight budget.
- An attractive product for them was achieved with the technology and materials employed.

Now tell student A as much as you can about the item.



VI. Now listen to the text about both items.

Read the job specification and write a covering letter (refer to extension to unit 1 how to write a covering letter):

1. If you are studying product design, read the text below.
2. If you are studying interior design, read the text on page 87.
3. If you are specializing in visual communication, read the text on page 72.

Cinimod Studio is looking for a talented **product designer** with strong workshop and fabrication skills. You will be working on the design and production of detailed technical projects of artworks which are produced to an exacting standard. The job will involve the design and engineering of the artworks, overseeing the fabrication by our suppliers as well as the final assembly and testing in our own workshop.

Job Specification

You must have a strong product design background, be highly skilled in 3-D modelling, and have experience working with various fabrication processes including (but not limited to): sheet metal working, laser/plasma cutting, CNC, and general carpentry. Experience with electronics is a bonus, but not a requirement.

The role will require travel around the UK and probably to international locations abroad to liaise with specialist suppliers and fabricators. You will also be attending site visits to assist in the installation of the completed works.

There are also a number of new projects and products where design work is needed from the earliest concept stage through to prototyping and production, and you may also be required to assist with other design tasks within the studio.

Candidate requirements: (see REVISION to Unit 19)

Job terms:

- salary to be determined based on experience
- standard job benefits/terms will apply

Application Process

You must visit our website in advance and understand the scope of work we undertake. In your cover email please discuss one project we have worked on and in just a short paragraph explain what you would have done differently. To apply, please email this statement along with a CV and portfolio to: growing@cinimodstudio.com with 'product designer and fabricator job application' in the subject line. We will arrange interviews with a number of applicants at our London studio.

Please visit our website for more information.

.....





The exercises must be done on the basis of the film dialogues.

I. Watch the film and then select the correct answer:

1. The students are looking at:

- a) a regular shopping trolley
- b a diploma project
- c) a new product

2. The presentation board comprises:

- a) detailed sketches and exploded drawings
- b) exploded drawings and precise dimensions
- c) precise dimensions and detailed sketches

3. The colours of the product are:

- a) subdued
- b) bright
- c) primary

II. Listen to the film dialogue carefully and circle the words that you hear:

extensive research
 cohesion
 handle
 seat
 MDF board
 caster wheels
 foam
 uniform
 pressing
 injection moulding
 adjustable
 portable
 cost evaluation
 matrix evaluation

III. Decide if the following sentences are true or false:

1. Tomasz knows a lot about the project of a walker from the Master's thesis that he read.
2. The device consists of three main parts.
3. The manufactured product should be made from steel and plastic.
4. The walker can be folded easily.
5. Students have to estimate the price of their designs.





UNIT 2

ex. II.

Armoire	– a large wardrobe or cabinet; originally used for storing weapons
Cabinet	– an upright, cupboard-like piece of furniture with shelves, drawers, or compartments for the safekeeping or display of objects
China cabinet	– a cabinet (usually with glass doors) for storing and displaying china
Draw table	– a table with a flat leaf or leaves that extend from beneath the tabletop to increase the size of the table
Dresser	– (US) a chest of drawers, (with a mirror) a vanity set; (BE) a cupboard
End table	– a small table, usually placed at either end of a couch or beside a chair
Filing cabinet	– office furniture consisting of a container for keeping papers in order
Hall tree	– (US) a piece of furniture where coats and hats and umbrellas can be hung; usually has a mirror; (BE) a hallstand
Headboard	– a vertical board at the head of a bed
Love seat	– a 'mini-sofa' – the same as the sofa from the collection it comes from, except for the width only seats two people
Ottoman	– an upholstered low seat or cushioned footstool
Recliner	– chairs, sofas or love seats that have a reclining backrest and may include an optional rising footrest
Sectional	– a large sofa in an L-shape to fit in the corner of a room
Settee	– a seat, for two or more people, with a back and usually with arms; couch
Sideboard	– a piece of dining room furniture having drawers and shelves for linens and tableware
Sofa bed	– a traditional sofa with a pullout (...) bed. It usually has a thin mattress and spring system. The metal frames greatly increase its weight
Vanity set	– a 'make-up set': a table, chair and mirror in one collection, for doing make-up

UNIT 3

ex. V.

Table/desk lamp: a small lamp with shade set on a table/desk for ambient or task lighting.

Floor lamp: a tall pole with support base, fixture and shade at top.

Torchier: a taller pole than standard with support base, fixture, halogen lamp and reflector at top. Often with a dimming capability.

Freestanding lamp: can take an endless variety of shapes.

UNIT 5

ex. IV.

Moulding:

A: a decorative recessed or relieved surface

B: a decorative plane or curved strip used for ornamentation or finishing

UNIT 7

ex. VIII.

In addition to different frames and different layouts, there are different glass panes and finishes that are used. An example would be a bathroom window with obscure or privacy glass. Objects are usually only visible when very close to the window. The glass has a pattern or frosted finish to it to prevent visibility of the room. Windows can also be single-glazed and double-glazed.

UNIT 9

ex. VIII.

The Design of the Interiors of a Contemporary Fashion Centre

The project was realized on the basis of an existing building, a former boiler house, situated in Paczkowska Street 26 in Wrocław. It was built in 1870 and currently is owned by the Polish National Railways PKP in Wrocław. I divided the interior of the building into three levels.

On the ground level there is a spacious main lobby. The main design concept was integrating the steps of the stairs with the information desk. The transformation of the steps into a built-in desk makes a coherent whole. The linearity and multiplication of the elements can be seen on each level. In the central part of the lobby I designed a seating area which suits the style of the interior. The seating unit is composed of horizontal elements, here made of varnished mahogany. The construction of the seating unit is supported by stainless steel elements attached to the floor and the ceiling. Besides, the materials used include stone flooring and wood of the seating unit as well as of the decorative details above the information desk. The walls are painted with mineral lime-based gloss paint, which gives the waxed effect and strong luminosity. The ceiling reflects the forms which are dominant in the design. It was made from plasterboards featuring grooves along which light can disperse uniformly.

There is a gallery on the first floor of the building. The details visible in this interior are designed for the effective display of clothes. The room's dominant design element is linearity and simplicity. The purity of forms made of plasterboard was contrasted with the raw brick wall. The floor was made of epoxy resin, which combines beauty with functionality. The simple forms – lines have been sunk into the white floor.

The second floor features a showroom, which was divided into two parts. In the first part there is a catwalk together with a seating area for the spectators. This part is an extension to the existing building. It is a simple solid, actually a cuboid, spiced up by vertical elements both outside, on the elevation, and inside in the room. The extension has made it possible to obtain sufficient space for the functions of the showroom.

The third floor is a coffee shop. It is connected with the lower area by a platform, made of steel units and glass. The platform offers good view of the catwalk. The coffee shop was furnished with tables and seating units. The furniture suits the style of the building. Purity of form and a lot of light – are the dominant features of the project!

Joanna Nowakowska

The Design of the Interiors of a Ballet School

The building in Legnicka Street 42 in Wrocław attracts attention with its carefully measured composition. Because of its pre-war ambience, the building (going back to 1889) seemed suitable to house a Ballet School. I could imagine the feet of ballerinas stroking the creaking wood floors... I tried to recreate a simple interior which would not interfere with the harmony of the building's shape. All the furniture which I placed inside was supposed to enhance the comfort of the users; at the same time by contrasting the soft texture of the upholstery – plum-coloured alcañtra – with the rough, hard wall I managed to get amazing visual and tactile impressions. The wall was additionally emphasized by a stream of ambient light, coming from a side. The rest of the artificial light is provided by tall lighting units. When switched off during the day, they make a special, so to say, interior sculpture, while at night they flood the six-metre high space with their subdued light, right from floor to ceiling. During my work on the project, searching for different forms, here angular, cubic rather than streamlined – I came across this concept of lighting fixtures. I wanted them to provide light for the huge space without dominating the interior. It turned out to be a really good idea. Similar lighting units were placed over the bar. The counter is made from walnut wood, supported – only visually – by a pane of glass. The real support is provided by long metal rods, sunk both in the counter and the wall.

The interior features three colours: strong and saturated – the colour of plum (the upholstery, the textile of the Roman blinds in the windows), light and delicate – beige (the ceilings, some of the walls and moulding on the front wall) and the colour of walnut (wooden elements in the interior). I do not like a lot of colours in the interior, my experience tells me that two, maximum three colours of the textiles, walls or flooring are perfectly enough. We have to remember that apart from these, people who enter the space will introduce additional colours, for example in their clothes. The ideal composition features one stronger colour, the second making the background for the first one and a third color – emphasizing the first two. Besides, we have to enrich the interior with textures: rough, smooth, silky, velvety... they disperse light beautifully. That is why I went for the juxtaposition of the smooth love seats in the cafeteria and the lighted texture of the wall behind.

There are also big panes of strengthened glass in the interior which is symbolically divided by them. I used them for example on the mezzanine, which spans part of the ground floor. The glass rails there are sunk in the floor several centimeters deep. The reflection of light on the glass pane, visible from the lobby, draws our attention but does not diminish the open space.

The lobby comprises the reception, restrooms for the guests and a seating area with a couple of soft, comfortable armchairs. The reception organizes the life of the school, which is also a centre of culture.

The building's clear and coherent circulation paths and simple yet sophisticated furnishings do not in any way clash with its ever so present 120-year old charm. Currently it has been put up for sale and is gradually falling into decline. But let us hope that sooner or later it will be appreciated, refurbished and brought back to its past glory.

Katarzyna Cichońska

UNIT 20

Revision

Experienced interior designer/London, UK

Interior designer/architect required for busy Chelsea practice. Minimum 3 years' exp, varied portfolio inc retail and residential exp and work to tight deadlines. We expect:

- clear sketching skills
- excellent all round CAD skills including Photoshop and Vectorworks 3-D
- experience running projects on site from conception to completion
- collaborative design experience
- intermediate Microsoft Office / OpenOffice skills
- experience developing concepts from both open ended briefs to tightly defined briefs
- excellent communication skills in terms of reading, writing and presentation to clients and suppliers
- strong work ethic and a great sense of humor!

Please submit applications to interior.designer@chelsea.com

UNIT 1

ex. V.

Chain game is a group activity in which one person says one word or phrase, the second repeats what the previous one has said and adds his/her word or phrase, the third repeats what the first two have said and adds his/her word or phrase, etc.

UNIT 4

ex. I.

1: Some reasons for painting a room: cracked paint, remodeling, dingy walls, new resident, design color change, patching holes.

UNIT 7

ex. I.

3. Some reasons for purchasing new windows: wood frames that are warped, poorly insulated, single pane without storm windows, drafty when the wind blows or ugly windows that would detract from the sale of a home.

UNIT 12

ex. I.

3. Materials needed to draw: wooden lead pencil, mechanical pencil, pencil sharpener, technical pen, fineliner, drawing board, circle template, compass, protractor, set square, ruler, white eraser, kneaded eraser, eraser shield, French curve, flexi curve, scale ruler, anglepoise lamp.

Types of paper: sketchbook, newsprint pad, recycled pad, tracing paper, craft paper, vellum roll or sheets, Bristol board, design board, cardboard.

ex. VII.

1. Draw the front vertical edge of the cube.
2. The sides of the box are drawn in at 30 degrees to the horizontal to the required length.
3. Draw in the back verticals.
4. Draw in the top view with all the lines drawn at 30 degrees to the horizontal.

ex. VIII.

Axonometric is a plan view at a 45-degree angle with the depth added vertically. All lengths are true lengths, the view is from above. One advantage of axonometric is that circles drawn on the top faces of objects can be drawn as normal circles.

UNIT 13

ex. I.

1. Perspective systems: aerial perspective, herringbone perspective, linear perspective; also: worm's-eye view, bird's-eye view, fish-eye lens.

UNIT 14

ex. V.

The **name** of the person who produced the drawing is important for quality control so that problems with the drawing can be traced back to their origin. / In many engineering firms, drawings are **checked** by a second person before they are sent to manufacture, so that any potential problems can be identified early. / Many drawings will get amended over the period of the parts' life. Giving each drawing a **version** number helps people identify if they are using the most recent version of the drawing. / The **date** the drawing was created or amended on. / The **scale** of the drawing. Large parts won't fit on paper so the scale provides a quick guide to the final size of the product. / Many CAD drawings may be distributed outside the company so the **company name** is usually added to identify the source.

ex. VII.

1. When you are hatching an object, but the object has areas that are separated, all areas of the object should be hatched in the same direction and with the same spacing.
2. When hatching assembled parts, the direction of the hatching should ideally be reversed on adjacent parts.
3. If more than two parts are adjacent, then the hatching should be staggered to emphasise the fact that these parts are separate.

UNIT 15

ex. V.

The two-point perspective is a much more useful drawing system than the more simple one-point perspective. Objects drawn in two-point perspective have a more natural look. The sides of the object vanish to one of two vanishing points on the horizon. Vertical lines in the object have no perspective applied to them.

UNIT 16

ex. I.

Read the text to find the answers:

Plastics are polymeric materials built up from long repeating chains of molecules. Polymers such as rubber occur naturally, but it wasn't until the development of synthetic polymers around 1910 that plastics tailored to the needs of the engineer first started to appear. One of the first commercial plastics developed was Bakelite and was used for the casing of the early radios. During the Second World War, plastics such as nylon and polyethylene were used as a replacement material for other materials in short supply. Because the early plastics were not completely chemically stable, they gained a reputation for being cheap and unreliable. However, advances in plastic technology since then mean that plastics are a very important and reliable class of materials for product design.

The mechanical properties of plastics tend to be inferior to most metals. Because of this, careful consideration must be given to using plastics for structural applications. Fibre-reinforced plastics are extensively used where the mechanical properties of the base plastic material are not sufficient. However, because of their relatively light weight, the ability to be coloured when manufacturing and the ability to mould complex shapes relatively easily, plastics are extensively used for product casings and other applications where mechanical strength is not at a premium.

Plastics are not cheap materials. The cost of raw plastic materials is typically higher than steel but lower than aluminium. However, because processing costs over large production runs are lower, the use of plastics can result in significantly cheaper products.

ex. VI.

(See also: Audio exercises)

11. CAD – Computer-Aided Design
12. CAM – Computer-Aided Manufacture
13. GRP – Glass-Reinforced Plastic
14. CNC – Computer Numerical Control
15. SLS – Selective Laser Sintering
16. FDM – Fused Deposition Moulding

UNIT 1

ex. III.

The Department of Interior Design was established in 1950. Currently the instruction at the department is based on four course modules – major instruction, general art instruction, complementary instruction and the humanities.

The studies are run in a two-degree system: Bachelor of Fine Arts and Master of Fine Arts. The BFA course lasts six semesters (three years) and the MFA course lasts four semesters (two years).

The major course offered to students on the first and second year of studies is aimed at teaching basic rules of the flat and three-dimensional composition as well as shaping materials. Students of the first years learn the fundamentals of programming, constructing and shaping the form of the furniture, exhibition space and the interior.

The students receive theoretical knowledge connected with the fundamentals of interior design, exhibition design and functional graphics. Volunteering students can take up the elective stage design and costume design courses.

After the second year the interior design students have the possibility of selecting one of the four diploma-awarding studios. These are three studios of Interior Design and one studio of Furniture Design.

The student completes two courses of studies by realizing the diploma work. It consists of: the diploma project, a thesis connected with the project theme and the fine arts annexe, realized in a selected general fine arts studio.

The graduates can find employment in architectural firms, interior design companies, advertising companies as well as furniture manufacturers – as furniture designers. They can work freelance in the field of interior, product, exhibition or stage design as well.

ex. IV.

The Department of Design of Industrial Forms was opened at the Academy of Art and Design in Wrocław in 1966. The students are prepared for complex designing of functional structures, workplaces and work environments, visual signs and statements in various systems, as well as complex informative structures in space, packages and lettering systems. They learn fundamentals of typographic techniques as well as presentation techniques.

In the first year the students learn issues connected with flat and spatial composition, geometry and technical drawing, preliminary design of industrial forms, graphic design with lettering, methodology of computer design, presentation techniques and elements of technical knowledge.

The general fine arts instruction is held in the studios of drawing and painting, as well as sculpture. In addition every year the students of the first year take part in outdoor painting sessions. It is possible to realize a fine arts annexe to the final diploma.

The students of design can realize the final diploma in one of the four MFA studios: Product Design Studio, Means of Transportation Design Studio, Work Environment and Tools Design Studio and Visual Communication Studio.

There are various forms of instruction: lectures, seminars, classes, as well as meetings with specialists not connected with the school. The studios organize work placements and workshops.

The MFA diploma in each of the studios comprises a project realized in the form of presentation boards, graphic layouts, mock-ups or models, and a thesis. The graduates are prepared for starting a freelance career in designing.

UNIT 2

ex. II.

Storage	Surface	Sets	Seating	Other
bookcase	coffee table	bedroom set	stool	street furniture
dresser	desk	dining set	stacking chair	park furniture
built-in furniture	end table	vanity set	footstool	hall tree
sideboard	bed		love seat	door furniture
china cabinet	folding table		rocking chair	headboard
armoire	table		sectional	
filing cabinet	bunk bed		ottoman	
wardrobe	four-poster bed		settee	
cupboard			armchair	
chest			bench	
cabinet			chair	
closet			folding chair	
			beanbag	
			sofa	
			couch	



UNIT 3

ex. IV.

FIXED LIGHTING

Pros: Focused light, long lasting, low maintenance, elegant.	Cons: Most require professional installation at construction time, inability to alter lighting layout easily.
---	--

A. RECESSED LIGHTING

Fixture	About	Pros	Cons
Canister downlights	The lighting fixture is mounted entirely into the ceiling and points downward. Ambient floodlight with soft fall-off.	Low fixture visibility	Uni-directional
Eyeballs	The lighting fixture is mounted into the ceiling and is directional. Downward, spotlight beam with hard edges creating dramatic shadows.	Omni-directional	High fixture visibility

B. SURFACE MOUNT/ARCHITECTURAL LIGHTING

Fixture	About	Pros	Cons
Sconce	A small fixture mounted to the wall that radiates light onto the wall and ceiling. Generally used as decorative or accent lighting.	High fixture visibility in decorative style. Can be replaced easily	Luxury lighting providing little usable light
Pendant/chandelier	The base is mounted to the ceiling with the lighting fixture suspended from it. Generally used over tables. Direct lighting with semi-hard shadows.	High fixture visibility. Can be replaced easily. Useful for tasks. Adds to overall brightness of room	Requires dusting. Hangs from the ceiling, reducing vertical space
Track lighting	A long track that powers moveable lighting elements. Generally mounted onto the ceiling or wall with various lighting element options.	Omni-directional used for accent lightings	High watt consumption
Undermount lighting	A lighting fixture mounted under a counter, cupboard, or at the foot of a cabinet. Indirect lighting with various dispersions.	Light is focused to area of use	Does not add to overall brightness of room

UNIT 4

ex. V.

Enamels are pigmented paints that produce a hard, glossy, durable surface, with the pigments ground finer in order to produce a smooth texture. They come in semi-gloss and gloss, but a flat appearance can be produced by adding a flattening agent. Enamels and other paints should be applied to a properly prepared surface. A glossy surface will not have tooth and should be sanded with sandpaper.

A primer is the first coat applied to the substrate to prepare for subsequent finishing coats. Some primers may serve as sealers which prevent the waste of paint caused by absorption of the porous materials.

Stains are pigments applied to bare or sealed wood and may be transparent or opaque, depending upon requirements. Stain waxes do the staining and waxing in one process, allowing the natural grain to show, while providing the natural finish of a wax.

Varnish is a transparent or pigmentless film applied to stained or unstained wood. When the surface of a varnish stain is scratched, the natural wood colour may show through.

UNIT 5

ex. IV.

recessed ceiling	a kind of suspended, (false, drop) ceiling
pilaster	a rectangular column, attached to the wall of a building for decoration
chair rail	surrounds a room at chair back height to prevent scuffing and damage to walls
niche	a recess in a wall especially for a statue.
picture rail	surrounds a room near top of the wall to facilitate hanging pictures. It can range from a shallow shelf to slotted trim to accept picture hooks.
baseboard, skirting board	a molding covering the joint of a wall and the adjoining floor
frieze	a sculptured or richly ornamented band (as on a building or piece of furniture). As architectural detail, it surrounds the room just below crown molding.
crown molding	surrounds a room where the wall meets the ceiling to hide uneven surfaces and provide visual interest
mantelpiece	a: the finish around a fireplace
	b: a shelf above a fireplace
in-wall fish tank	a glass case in the wall where you can keep fish

UNIT 6

ex. VIII.

- A. Loop tile has a surface consisting of uncut loops. Variations include high and low loops and various colours.
- B. Cut pile (plush) is manufactured with looped material and cut for a smooth finish. This is a very basic style of carpeting. This textured carpet hides soil and traffic patterns and is easy to work with.
- C. Freize (hard twist) is cut pile from a highly twisted yarn. It will hide footsteps, prevent shedding and the shading which occurs when the pile lies in opposite directions.
- D. Semi-shag (splush) is soft cut pile with shorter piles than shag.
- E. Shag is a soft carpet with long pile.
- F. Berber Carpet is made by machine with a country homespun effect with natural colours. Thicker yarns hide both foot prints and vacuum tracks. Usually coarse loop pile, but also made in cut pile, shags and a variety of designs, Berber is most often used in contemporary rooms.

UNIT 7

ex. II.

1. Skylight – a flat or sloped window used for daylighting, built into a roof structure that is out of reach.
2. Roof window – a sloped window used for daylighting, built into a roof structure that is within reach.
3. Jalousie window (also known as louvered window) consists of parallel slats of glass or acrylic that open and close like a Venetian blind.
4. Sash window– the traditional style of window in the USA, and many other places that were formerly colonized by the UK, with two parts (sashes) that overlap slightly and slide up and down inside the frame.
5. Horizontal slider has two or more sashes that overlap slightly but slide horizontally within the frame.

UNIT 8

ex. III.

The type of kitchen desired depends upon availability of space, life style, and ages and number of family members. Expense and space are the limiting factors in kitchen design. The best utilization of space will create a functional and enjoyable working area.

A small kitchen will appear larger with an open plan that is, without a wall dividing it from the adjacent room. It will also appear larger with a vaulted ceiling. A young couple with a beginning family might require a family room within the sight of the parents. Teenagers like to be near food preparation areas for easy access to refrigerator and snacks. All these factors need to be taken into consideration when planning a kitchen.



UNIT 9

ex. II.

take on	the appearance
make	the most of an existing space
knock down	the partitioning walls
give	a sense of unity
fit in	the bedroom
play on	the colour contrasts
reinforce	the design features
add	lightness
bring in	natural light
create	perfect harmony

ex. V.

rethink	the layout
tackle	the work
restore	the ceiling
house	the kitchen
scrape	the flagstones
rub	with linseed oil
attract	the attention
add	a symbolic touch
offer	a view
complete	the scheme

UNIT 10

ex. II.

DESIGN BRIEF, PRODUCT DESIGN SPECIFICATION, CONCEPT DESIGN, DETAIL DESIGN, MANUFACTURING AND TESTING, SALES.

ex. III.

- **Manufacture** – Can the product be made with our facilities?
- **Sales** – Are we producing a product that the client wants?
- **Purchasing** – Are the parts specified in stock or do we have to order them?
- **Cost** – Isn't the design going to cost too much to make?
- **Transport** – Is the product the right size for the method of transport?
- **Disposal** – How will it be disposed of?

UNIT 11

ex. II.

CONCEPT DESIGN

Using the Product Design Specification as the basis, the designer attempts to produce an outline of a solution. A conceptual design is usually an outline of the key components and their arrangement. The details of the design are left for a later stage. For example, a concept design for a car might consist of a sketch showing a car with four wheels and the engine mounted at the front of the car. The exact details of the components such as the diameter of the wheels or the size of the engine are determined at the detail design stage. However, the degree of detail generated at the conceptual design stage will vary depending on the product.

This stage of the design involves drawing up a number of different viable concept designs which satisfy the requirements of the product outlined in the PDS and then evaluating them to decide on the most suitable to develop further. So concept design can be seen as a two-stage process of concept generation and concept evaluation.

UNIT 12

ex. V.

Isometric is a mathematical method of constructing a three-dimensional object without using perspective. Isometric was an attempt to make drawings more realistic.

The mathematics involved means that all lengths when drawn at 30 degrees can be drawn using their true length (in other words lines are not shortened as with oblique drawings).

An isometric drawing shows two sides of the object and the top or bottom of the object.

All vertical lines are drawn vertically, but all horizontal lines of the object are drawn at 30 degrees to the horizontal line of the drawing. Isometric is an easy method of constructing reasonable 'three-dimensional' images.

ex. VI.

Cube, sphere, cone, cylinder, cuboid, square, triangle, rectangle, circle, rhomb.

UNIT 13

ex. III.
 Using one-point perspective, parallel lines converge to one point somewhere in the distance. This point is called the vanishing point. This gives objects an impression of depth.
 When drawing using one-point perspective all objects vanish to one common point somewhere on the horizon. The sides of an object diminish towards the vanishing point. All vertical and horizontal lines are drawn with no perspective. i.e. face on.
 The use of one-point perspective is limited because the main problem is that the perspective makes small products look bigger than they actually are. One area where one-point perspective can be quite useful is for sketching room layouts.

ex. VII.
 The linework took less than two minutes and is intentionally rough just to lay in general perspective and proportion. Make sure the linework is light on the paper so that you can erase most of it later. Be spontaneous! Listen to good music, that always helps me. If you are getting stuck for ideas, it helps to alter an element of the process – maybe sketch with a different tool, try a completely different perspective, different paper, or even go to a different location and sketch. If you do the same thing repeatedly, your mind sometimes learns the process too well and things become automatic – new designs won't come to you unless you throw your brain something new to deal with. This is just my theory, but it seems to work for me. If you are drawing the same car over and over again, quit and move to a different company!

UNIT 14

ex. III.
 Dimensions are always drawn using continuous thin lines. Two projection lines indicate where the dimension starts and finishes. They do not touch the object and are drawn perpendicular to the element you are dimensioning.
 In general, units can be omitted from dimensions if a statement of the units is included on your drawing. The general convention is to dimension in millimeters.

ex. IV.
 Parallel Dimensioning, Superimposed Running Dimensions, Chain Dimensioning, Dimensioning by Coordinates, Dimensioning Small Features.

ex. VII.
 hatching, staggered hatching, reversed hatching, cross-hatching

UNIT 15

ex. III.
Steel in one form or another is the most widely used material for engineering purposes. Steel is an alloy of iron and carbon, with the proportion of carbon having a large influence on the properties of the steel. The carbon content of steel can be anything from 0.08 % to 2 %. There are a large number of different steel alloys available. Two main families of steels are: carbon (mild) steel and stainless steel.
Carbon steel is sometimes referred to as 'mild steel' or 'plain carbon steel'. The American Iron and Steel Institute defines a carbon steel as having no more than 2 % carbon and no other appreciable alloying element. Carbon steel makes up the largest part of steel production and is used in a vast range of applications.

UNIT 16

ex. IV.
 • **Thermosetting plastics** are rigid plastics, more resistant to higher temperatures than thermoplastics. Once set, thermosets cannot be remoulded. There are several common thermosetting plastics, for example:
 • **Epoxies** come in resin form and are cured and set after which they cannot be remoulded. The agent added to the resin to cause it to start and cure (go hard) can alter the properties of the plastic considerably. Epoxies have excellent chemical resistance and are hard, rigid and sometimes brittle. They have excellent adhesion properties and are therefore used as adhesives.
 • **Polyesters** are hard and brittle but they can be combined with fiberglass to produce a glass-reinforced plastic (GRP) which is used for car bodies, sailing boats and furniture. GRP's can be used for structural purposes but they are very expensive. They are available in flexible rolls that harden when a catalyst is added to produce a strong rigid shell.



ex. VI.

- PP – Polypropylene; food containers, appliances, car fenders and bumpers.
 PS – Polystyrene; packaging foam, food containers, disposable cups, plates, cutlery, CD and cassette boxes.
 HIPS – High impact polystyrene; fridge liners, food packaging, vending cups.
 PET – Polyethylene terephthalate; carbonated drinks bottles, jars, plastic film, microwavable packaging.
 PES – Polyester; fibers, textiles.
 PA – Polyamides (Nylons); fibers, toothbrush bristles, under-the-hood car engine moldings.
 PVC – Polyvinyl chloride; plumbing pipes and guttering, shower curtains, window frames, flooring.
 PU – Polyurethanes; cushioning foams, thermal insulation foams, surface coatings, printing rollers.
 (Currently 6th or 7th most commonly used plastic material, for instance the most commonly used plastic found in cars).
 PC – Polycarbonate; compact discs, eyeglasses, riot shields, security windows, traffic lights, lenses.
 ABS – Acrylonitrile butadiene styrene; electronic equipment cases (e.g. computer monitors, printers, keyboards); also: AntiLock Breaking System.

UNIT 17

ex. II.

Casting is a process in which molten material is poured into a mould of the required shape and then allowed to solidify.

Moulding is a similar process used to form plastic materials. The mould should be shaped so that the material flows to all parts of the mould.

UNIT 18

ex. I.

Fabrication technique involves making components up from stock materials. The material is first cut to the required shape. Then it is joined using a suitable joining technique. This process is suitable for small production runs because the high initial costs associated with other processes such as casting are avoided. It is not so suitable for large production runs because of its labour-intensive nature.

UNIT 19

ex. I.

Machining techniques

All machining processes remove material to form shapes. As metals are still the most widely used materials in manufacturing, machining processes are usually used for metals. However, machining can also be used to shape plastics and other materials which are becoming more widespread. Basically all the different forms of machining involve removing material from a component using a rotating cutter. The differences between the various types arise from the relative motion between cutting tool and workpiece and the type of cutting tool used.

Advantages

- Machining processes allow high precision components to be rapidly produced.

Disadvantages

- Machining processes are not suitable for removing large amounts of material.
- There can be a large amount of wastage.

UNIT 20

ex. VI.

The design concept (of the FALA toothbrush) relies on a wavy handle. The form serves two functions: the contour improves the grip by offering gentle resistance to fingers, and the smooth surface is easy to keep clean. The waviness is also decorative and different. Clear plastic is used, in cold colours ranging from green through blue to navy. The wavy shape, colours, transparency, and the name meaning 'wave', all make an association with water and cleanliness. The toothbrush head is oval, and angled for reaching less accessible spots. Its fibres have rounded ends so as not to irritate the gums. The brushes are made in three grades of stiffness, and two sizes (...).

The ZEFIR's design met the esthetic standards of the 1960s, while society made special use of it: as often as not, the ZEFIR was found in the display windows of shops and small businesses. This little fan with little power was used to prevent the windows from fogging, and was also a decorative little gadget when placed among the flower pots and modern ceramics. It was a mark of modernity, not only because of its pleasing appearance, enhanced by the stylishly lettered logo, but also because it was, like transistor radios, a device designed for private use, a kind of proxy for the more elaborate achievements of modern technology and gadget mania then beyond the reach of Poles.

(...) The 'classic' design had an (...) appealing two-tone (orange/white or blue/white) rounded housing and a graceful base.









BIBLIOGRAPHY

Magazines and Periodicals

Art and Decoration (Paris, 2004); *Financial Times* (New York, 2009); *Western Morning News* (Plymouth, 2009)

Books

Corbeil, J., Archambault A., Wielojęzyczny słownik wizualny (Warszawa, 1996); Fiell, Ch.&P., *Industrial Design A-Z* (Koln, 2000); Gareth, W., *The furniture machine* (London, 2010); *Longman Dictionary of contemporary English* (Harlow, 2003); Pile, J., *A History of Interior Design* (London, 2005); Postell, J., *Furniture Design* (New Jersey, 2007); Riggs, J. R., *Materials and Components of Interior Architecture* (New Jersey, 1996); *Rzeczypospolite* (Olszanica, 2001); Tangaz, T., *The interior design course* (London, 2009); Zell, M., *The Architectural Drawing Course* (London, 2008)

Websites

www.wikipedia.org; www.designmuseum.com; www.ider.herts.ac.uk; www.cardsignnews.com; www.dezeenjobs.com; <http://designmuseum.org>; <http://akvis.com/en/photoshop-tips/index.php>; www.nissan.co.uk; <http://www.bbc.co.uk/homes>; http://homeguide123.com/video_library/Flooring_Videos.html; www.seemydesign.com; <http://www.thefreedictionary.com>

DVD

Akademia Sztuk Pięknych we Wrocławiu, DVD (Wrocław, 2007)

NOTES

Unit 1

Ex. III, IV — adapted from: *Akademia Sztuk Pięknych we Wrocławiu*, 2007
Ex. VI, VII — adapted from: Tomris Tangaz, *The interior design course*, 2009, p. 131
EXTENSION: Tomris Tangaz, *The interior design course*, 2009, pp. 126-127

Unit 2

Ex. I: 3. www.wikipedia.org (bold letters by Beata Ludwiczak)
Ex. III, IV — adapted from: www.ider.herts.ac.uk
Ex. VI — adapted from: www.designmuseum.com
EXTENSION: Williams Gareth, *The Furniture Machine. Furniture since 1990*, 2010, p. 60

Unit 3

Ex. II, IV — adapted from: www.seemydesign.com
Ex. VI: 1. — adapted from: www.designmuseum.com; 2, 3, 4 – descriptions of exhibits in V&A Museum
Ex. VII — adapted from: Tomris Tangaz, *The interior design course*, 2009, p. 99
REVISION — adapted from: John Postell, *Furniture Design*, 2007, chapter 3
EXTENSION: Williams Gareth, *The Furniture Machine. Furniture since 1990*, 2010, p. 37

Unit 4

Ex. II — adapted from: Tomris Tangaz, *The interior design course*, 2009, p. 100
Ex. III: J. Rosemary Riggs, *Materials and Components of Interior Architecture*, 1996, pp. 17-18
Ex. IV, V — adapted from: J. Rosemary Riggs, *Materials and Components of Interior Architecture*, 1996, chapter 2
Ex. VII — adapted from: www.seemydesign.com
Ex. X — adapted from: Tomris Tangaz, *The interior design course*, 2009, p. 100
REVISION: www.bbc/homes
EXTENSION: Jenny Dalton, 'How's tricks?' in *How to spend it*, supplement to: *Financial Times*, May 2009

Unit 5

Ex. II, IV — adapted from: www.seemydesign.com
Ex. V — adapted from: J. Rosemary Riggs, *Materials and Components of Interior Architecture*, 1996, p. 125
Ex. VI — adapted from: www.seemydesign.com
Ex. VIII — adapted from: www.wikipedia.org
REVISION — adapted from: www.bbc/homes
EXTENSION: John Pile, *A History of Interior Design*, 2005, pp. 190-191

UNIT 6

Ex. I — adapted from: www.wikipedia.org
Ex. II — adapted from: www.seemydesign.com
Ex. III — definition of flagstone: *Longman Dictionary of contemporary English* (Harlow, 2003)
Ex. IV, V, VI — adapted from: www.seemydesign.com
Ex. VIII, A, C, D, E — adapted from: J. Rosemary Riggs, *Materials and Components of Interior Architecture*, 1996, p. 27
B, F — http://homeguide123.com/video_library/Flooring_Videos.html
REVISION — adapted from: www.bbc/homes
EXTENSION — adapted from: *Westcountry Homes*, supplement to: *Western Morning News*, Nov 7th, 2009

Unit 7

Ex. I — 3. adapted from: www.seemydesign.com
Ex. II, IV, VI — adapted from: www.wikipedia.org

REVISION — adapted from: www.bbc/homes
EXTENSION: John Pile, *A History of Interior Design*, 2005, pp. 407-408

Unit 8

Ex. II: J. Rosemary Riggs, *Materials and Components of Interior Architecture*, 1996, p. 155
Ex. III, IV, V — adapted from: J. Rosemary Riggs, *Materials and Components of Interior Architecture*, 1996, pp. 155-156
Ex. VIII: op. cit., p. 175-176
REVISION — adapted from: www.bbc/homes
EXTENSION: John Pile, *A History of Interior Design*, 2005, pp. 359-360

Unit 9

Ex. I — adapted from: Isabelle Chabeur, *Made to Measure* in *Art & Decoration*, September, 2004, p. 267
Ex. IV — adapted from: Martine Freyne, *A Gentle Retreat* in *Art & Decoration*, October, 2004, p. 265

Unit 10

Ex. II, III, IV, V, VI, VII — adapted from: www.ider.herts.ac.uk
Ex. IX: Tomris Tangaz, *The interior design course*, 2009, p. 38

Unit 11

Ex. II, IV, V, VI — adapted from: www.ider.herts.ac.uk
EXTENSION — adapted from: www.nissan.com

Unit 12

Ex. II, III, IV, V, VII — adapted from: www.ider.herts.ac.uk
EXTENSION — adapted from: <http://akvis.com/en/photoshop-tips/index.php>
Film dialogue inspired by: www.cardsignnews.com

Unit 13

Ex. II, III, IV, V, VI — adapted from: www.ider.herts.ac.uk
Ex. VII: www.cardsignnews.com
EXTENSION: 1. Tomris Tangaz, *The interior design course*, 2009, p. 60;
2. Mo Zell, *The Architectural Drawing Course*, 2008, p. 26

Unit 14

Ex. I: <http://www.thefreedictionary.com>
Ex. II, III, IV, V, VI, VII: www.ider.herts.ac.uk
EXTENSION — adapted from: Tomris Tangaz, *The interior design course*, 2009, p. 28

Unit 15

Ex. II, III, IV, V, VI — adapted from: www.ider.herts.ac.uk
EXTENSION: Tomris Tangaz, *The interior design course*, 2009, p. 104

Unit 16

Ex. II, III, IV — adapted from: www.ider.herts.ac.uk
Ex. V, VI — adapted from: www.wikipedia.org
Ex. VII — adapted from: Charlotte & Peter Fiell, *Industrial Design A-Z*, 2000, pp. 646-647
REVISION — adapted from: www.ider.herts.ac.uk
EXTENSION: Williams Gareth, *The Furniture Machine. Furniture since 1990*, 2010, p. 96

Unit 17

Ex. I, II, III — adapted from: www.ider.herts.ac.uk
REVISION — adapted from: www.dezeenjobs.com
EXTENSION: Williams Gareth, *The Furniture Machine. Furniture since 1990*, 2010, p. 109

Unit 18

Ex. I, II, III, IV, V, VI — adapted from: www.ider.herts.ac.uk
EXTENSION: Williams Gareth, *The Furniture Machine. Furniture since 1990*, 2010, pp. 114-115

Unit 19

Ex. I — adapted from: www.ider.herts.ac.uk
Ex. II: <http://www.thefreedictionary.com>
Ex. III — adapted from Charlotte & Peter Fiell, *Industrial Design A-Z*, 2000, pp. 650-651
Ex. IV, V — adapted from: www.ider.herts.ac.uk
REVISION: www.dezeenjobs.com
EXTENSION: Williams Gareth, *The Furniture Machine. Furniture since 1990*, 2010, pp. 92-93

Unit 20

Ex. II — adapted from: Czesława Frejlich, *1993 Lamela bread box* in *Rzeczypospolite*, 2001, p. 242
Ex. IV adapted from: Czesława Frejlich, *1976 Vela 203 portable television* in *Rzeczypospolite*, 2001, p. 214
Ex. VI:
— adapted from: Czesława Frejlich, *1964 Zefir electric fan* in *Rzeczypospolite*, 2001, p. 170
— adapted from: Czesława Frejlich, *1995 Fala toothbrush* in *Rzeczypospolite*, 2001, p. 248