

Research Article

Open Access

Piotr Srokosz*, Ireneusz Dyka, Marcin Bujko

Interpretation of shear modulus degradation tests

<https://doi.org/10.2478/sgem-2018-0015>

received March 22, 2018; accepted June 10, 2018.

Abstract: The problem is a continuation of the research conducted at the University of Warmia and Mazury in Olsztyn, Institute of Building Engineering. It concerns the development of methods for the interpretation of the shear modulus measurements based on the tests conducted on a torsional shear (TS) apparatus. The issue has significant importance in determining the deformation parameters, essential to perform numerical simulations of the interaction between a geotechnical structure and the subsoil. The purpose of this study was to conduct a comparative analysis of the various methods of interpretation of research results based on direct and reverse analysis, as well as automated classification of the first cycle of the relationship between the shear stress and the shear strain components obtained from the TS test. The methodology for verification of the presented interpretative methods consists in carrying out a series of laboratory tests on non-cohesive and cohesive samples of different granulation and state parameters. The course of the research includes the following steps: elaboration of the granulometric composition of several samples of soil, determination of soil index properties and execution of TS tests. Various methods of interpretation of obtained results were taken into account, in addition to conducting a comparative analysis. The study used a non-standard interpretation approach consisting of analysing one-fourth of the hysteresis loop of the first load–unload cycle of the tested samples. The obtained results confirmed the hypothesis that it is possible to estimate the degradation value of the shear modulus based on a part of the TS test results carried out under quasi-monotonic load conditions. The proposed methods of interpreting test results have confirmed their high usefulness, which is devoid of the uncertainty associated with standardised resonant column/TS testing.

Keywords: torsional shear; back analysis; cluster analysis; shear modulus; small strains.

1 Introduction

One of the key parameters essential for conducting numerical analyses of the geotechnical structure or to conduct its design calculations is the deformation modulus of the separated soil layer. The basis for determining the magnitude of the deformation modulus is the stress–strain relation obtained by an empirical study of the appropriately prepared soil sample. Traditionally, the test enabling the determination of the relationship between the states of stress and strain is the triaxial compression test conducted on cylindrical test specimens. In these tests, extremely important are the particular measurement methods used to determine the value of the vertical component of the compressive stress and the strain of the soil sample for the determined conditions (consolidation and drainage conditions, rate of shearing, etc.). Determination of the momentary strain of the soil sample (for a given and recorded state of stress) requires advanced techniques for the precise control of the changing dimensions of the sample.

The accuracy of continuous measurement of changing physical quantities is a very important issue in soil studies due to the non-linearity of the manifested mechanical characteristics, e.g. the non-linear change (degradation) of the deformation modulus with the increase in strain. Many computational methods (to a greater or lesser extent adapting the basis of the theory of elasticity) require knowledge of the exact values of the deformation modulus as the most important material parameter. It should be defined according to the used calculation method (Figure 1). Moreover, knowledge of the value of E_{ur} (*unload–reload modulus*) is required for issues including unloading of the subsoil.

In many cases of numerical analysis of geotechnical problems, each stage of the development of the state of stress and strain should be considered, dealing with strains in the range of $\varepsilon < 10^{-3}$. In this range, the variation in the deformation modulus is the greatest. Due to

*Corresponding author: Piotr Srokosz, Faculty of Geodesy, Geospatial and Civil Engineering, University of Warmia and Mazury in Olsztyn, E-mail: psrok@uwm.edu.pl

Ireneusz Dyka, Marcin Bujko: Faculty of Geodesy, Geospatial and Civil Engineering, University of Warmia and Mazury in Olsztyn

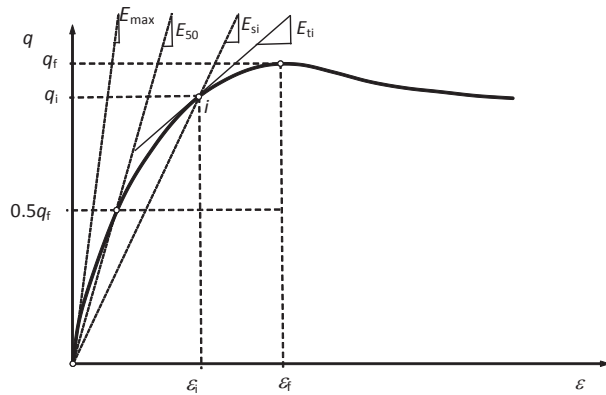

Figure 1: Non-linear stress–strain characteristics: E_s – secant modulus, E_t – tangent modulus.

the technical conditions of the triaxial compression apparatus, the results of the tests determining the general deformation modulus E and its variability are not accurate enough, particularly, in the range of strain below 0.1%. In computational procedures, other measures of soil stiffness are used more often. In the past decades, the basic parameter characterising the stiffness of soils has become the shear modulus G . In the hardening soil (HS)-small constitutive model [1, 2], constituting the extension of the HS model, the shear stiffness parameter G is used. According to the formula used [3], the value of parameter G degrades as a function of the deformation γ :

$$G(\gamma) = \frac{G_u}{1 + a \frac{\gamma}{\gamma_u}} \quad (1)$$

where: G_{\max} – initial shear modulus for very small strain ($\gamma \gg 10^{-6}$), a – a constant (0.385), γ – shear strain and $\gamma_{0.7}$ – reference shear strain corresponding to $G = 0.7 \cdot G_{\max}$.

The concept of threshold strain, beyond which the soil behaviour depends on the number of load cycles, was introduced by Lo Presti [4] and recorded by Vucetic [5]. According to Tabata and Vucetic [6], the threshold strain value depends on the plasticity index I_p and slightly on the overconsolidation ratio (OCR). It was observed that the threshold strain value most often corresponds to $G = (0.65-0.67) \cdot G_{\max}$ and therefore a normalised reference strain parameter, $\gamma_{0.7}$ was proposed, which corresponds to $G = 0.7 \cdot G_{\max}$.

In many calculation methods for subsequent phases of subsoil loading, it is required to use a tangent modulus, the value of which changes depending on strain and stress. Such an analytical solution was used, among others, in the method of determining the settlement curve of a single pile loaded with axial force [7].

In the modelling of many engineering problems, it is extremely important to determine the expected degradation of the value of the strain modulus, which can be presented in the following generalised form [8]:

$$G = G_{\max} \cdot F(\gamma) \quad (2)$$

where $F(\gamma)$ is the stiffness degradation function.

The authors of this work became interested in determining this function. It should be noted that the initial shear modulus G_{\max} is considered a state parameter of the soil for both drained and undrained conditions [9].

The proposal of a new method for determining the soil stiffness degradation curve is based on the assumption that the intact soil structure undergoes the most significant changes in the first phase of the cyclic load applied during the torsional test (first quarter of the hysteresis loop). An interesting fragment of the hysteresis loop can be successfully recorded in detail during the test carried out at very low rates of torque changes and high frequency of recording measured physical quantities. The proposed concept eliminates the necessity for repeated soil testing at various levels of applied strain. It allows the determination of the full course of soil stiffness degradation only on the basis of the results of a single test. The article has been divided into the following parts: a synthetic description of the selected G modulus degradation functions, results of research on three types of soil in the RC/TS apparatus, alternative interpretations of the obtained results, summary and conclusions.

2 Degradation Functions of G Modulus

The variability of the G module is most often described as the hyperbolic function of the relationship between the current value of the G modulus and the value of the tangential stress component τ or the value of the actual level of the shear strain γ . An example of such a relation is the function used in the hypo-elastic constitutive model presented by Duncan and Chang [10]:

$$\tau = \frac{1}{\frac{1}{G_{\max}} + \frac{\gamma}{\tau_{\max}}} \quad (3)$$

where: τ – actual tangential stress, γ – actual shear strain and τ_{\max} – shear strength (limit shear stress before failure).

Based on the above equation, Hardin and Drnevich [11], introducing an additional parameter controlling the shape of the curve, namely the reference strain γ_r , the function of degradation of the G modulus was presented in the following form:

$$G = G_{\max} \frac{1}{1 + \frac{\gamma}{\gamma_r}} \quad (4)$$

where $\gamma_r = \frac{\tau_{\max}}{G_{\max}}$.

This equation can also be presented as a function of the value change of tangential stress:

$$G = G_{\max} \left(1 - \frac{\tau}{\tau_{\max}} \right) \quad (5)$$

In the above model of the G modulus degradation, a constant Poisson coefficient is assumed. The value of the G modulus represents the secant modulus in the range of the analysed tangential stress component ($0, \tau$).

The modified form of the hyperbolic G degradation function was used to predict the axial compression curves of the piles, introducing an additional R_f parameter controlling the shape of the function [12]:

$$G = G_{\max} \cdot \left(1 - \frac{\tau \cdot R_f}{\tau_{\max}} \right) \text{ for secant modulus and } (6)$$

$$G = G_{\max} \cdot \left(1 - \frac{\tau \cdot R_f}{\tau_{\max}} \right)^2 \text{ for tangent modulus } (7)$$

where the constant of the hyperbolic curve is taken in the range of $R_f = 0.5-0.9$.

In 1993, Fahey and Carter [13] proposed a hyperbolic function of variability of the shear modulus in the generalised form:

$$G = G_{\max} \cdot \left(1 - f \left(\frac{\tau}{\tau_{\max}} \right)^g \right) \quad (8)$$

where f and g represent constant coefficients.

Kuwabara [14] proposed a relationship for the analysis of axial-loaded piles in which a linear characteristic for the change of the G modulus was assumed as a function of $\log(\gamma)$ in the range of $10^{-2}\% < \gamma < 1\%$. On the other hand, Van Impe and De Clercq [15] applied the G modulus degradation function in a slightly modified form:

$$G = \begin{cases} G_{\max} \text{ for } \gamma \leq 10^{-3}\% \\ -G_{\max} (0.3 \log(\gamma) + 0.5) \text{ for } 10^{-3}\% < \gamma < 1\% \\ 0.1 G_{\max} \text{ for } \gamma \geq 1\% \end{cases} \quad (9)$$

Darendeli [16], in his Ph.D. thesis under the supervision of Professor Stokoe, proposed a modification of the Hardin and Drnevich equation, a lower value of the reference strain (Eq. 10). The defined reference strain corresponds to the value of tangential stress at which $G/G_{\max} = 0.5$ ($\gamma_r = \gamma_{0.5}$).

$$G = G_{\max} \frac{1}{1 + \left(\frac{\gamma}{\gamma_r} \right)^a} \quad (10)$$

where a is the exponent, which Darendeli assumed as 0.92, and Vardanega and Bolton [17, 18] assumed as 0.736 at the reference strain γ_r dependent on the plasticity index.

A comparison of the selected degradation functions of the modulus is shown in Figure 2.

The problem of describing the function of the strain modulus degradation in the modelling of mechanical phenomena occurring in various geotechnical problems is still being developed. Each formula is verified on the basis of the results of laboratory tests using a triaxial apparatus, a resonant column (RC) or a torsional shear (TS) apparatus. Most of the above-mentioned shear modulus degradation functions were created on the basis of soil analysis studies in the RC. In the research, the dependence of the shape of the degradation curve was determined, among others, on the isotropic stress value and the plasticity index.

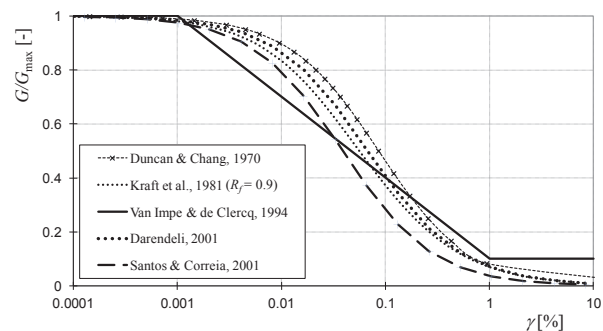

Figure 2: Comparison of the G modulus degradation function according to the selected formulas.

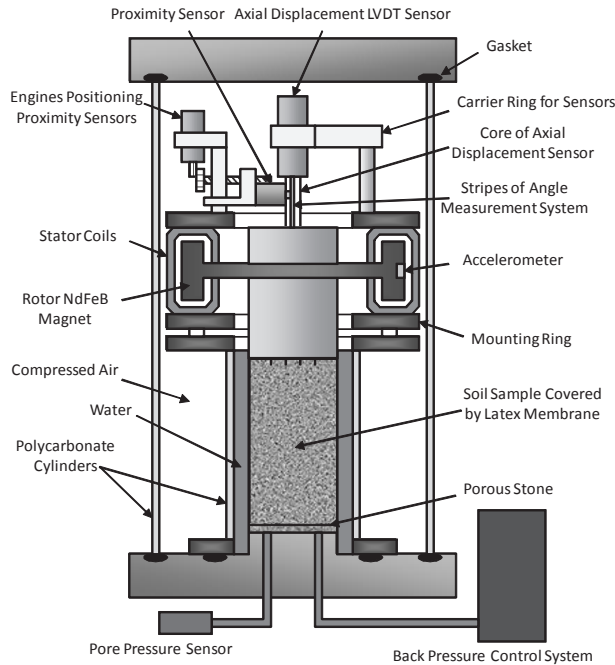

Figure 3: RC/TS apparatus scheme.

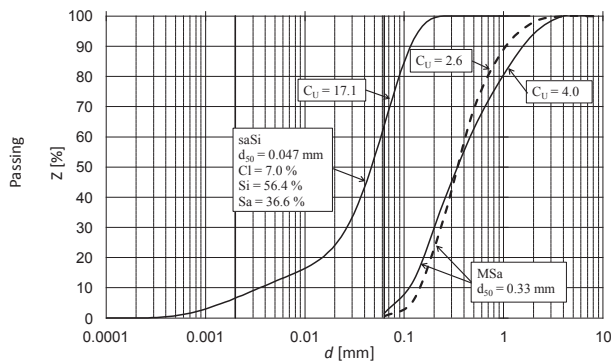

Figure 4: The granulometric composition of the studied soils.

3 Research on The RC/TS Apparatus

The RC/TS apparatus is part of the equipment of the Geotechnical Laboratory in Olsztyn (31-WF8500 model). It is a device that can function as a RC or a TS apparatus. In the RC mode, the apparatus enables dynamic, cyclic excitation of torque in the tested soil sample with a frequency of up to 300 Hz. In the TS mode, the apparatus generates a cyclic load with a frequency in the range of 0.01–50 Hz. The scheme of the device is shown in Figure 3.

Three types of soil were tested: one cohesive (intact silt) and two non-cohesive (reconstituted medium sands). Reconstitution of the non-cohesive soil specimen consisted of forming a sample by compaction in a cylindrical form

Table 1: Parameters of tested soils.

Soil	G_s [-]	d_{50} [mm]	I_p	C_u [-]	e [-]	ρ [kg/m ³]
Sandy silt saSi	2.66	0.047	0.11	17.1	0.67	1870
Medium sand MSA (1)	2.65	0.33	-	2.6	0.42	1860
Medium sand MSA (2)	2.65	0.33	-	4.0	0.37	1930

Table 2: Parameters of tested samples.

Sample	Soil	Diameter, mm	Height, mm	Cell pressure, kPa	Maximum angle, mrad
S3057	Sandy silt saSi	70.2	141.4	100–300	17.2
S5919	Medium sand MSA (1)	70.0	143.1	50–200	2.2
S3935	Medium sand MSA (2)	72.8	143.2	50–400	1.3

and applying constant confining pressure for 24 hours. Detailed characteristics of these samples are summarised in Tables 1 and 2, as well as in Figure 4.

A synthetic graphical visualisation of the stiffness degradation test results in the RC/TS apparatus is shown in Figures 5–7. Due to the low stiffness values of the S3057 sample, it was possible to obtain a degradation of the G modulus in its full range of useful strain.

Due to the control of twisting with the torque value, different rigidity of samples results in different strains in all specimens. High stiffness of samples prepared from non-cohesive soils made it impossible to obtain sufficiently large torsion angles to observe the effect of decreasing the rate of G value degradation.

4 Alternative Interpretation of TS Test Results

Obtaining the full process of the soil stiffness degradation phenomenon is quite a difficult task, due to the hardware limitations associated with the generation of a correspondingly high value of torque (in the WF8500 apparatus, it is driven by electrical signal). Conducting many different tests on the same sample (e.g. RC and TS

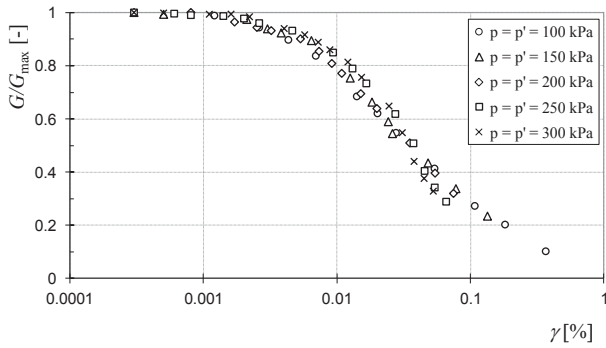

Figure 5: The results of the RC tests for sample S3057.

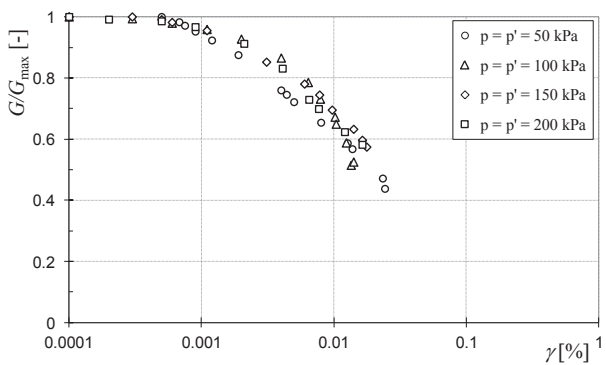

Figure 6: The results of the RC tests for sample S5919.

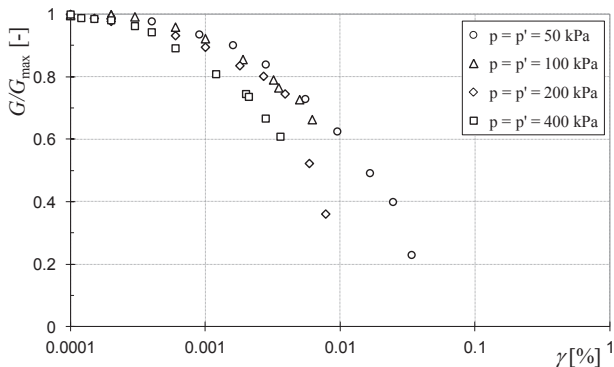

Figure 7: The results of the RC tests for sample S3935.

at different chamber pressures) leads to false results due to the phenomenon of stiffness degradation. On the other hand, the reproducibility of the results of tests conducted on different samples is too small to be successfully used in each case of the type and condition of the tested soil (unless the tests are carried out on reconstituted specimen). The authors therefore propose alternative methods for the

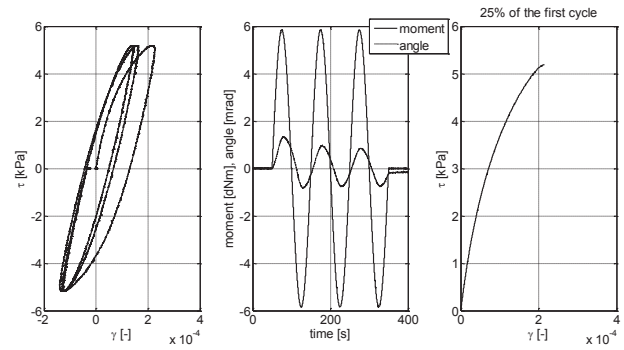

Figure 8: The results of the TS test of sample S3935.

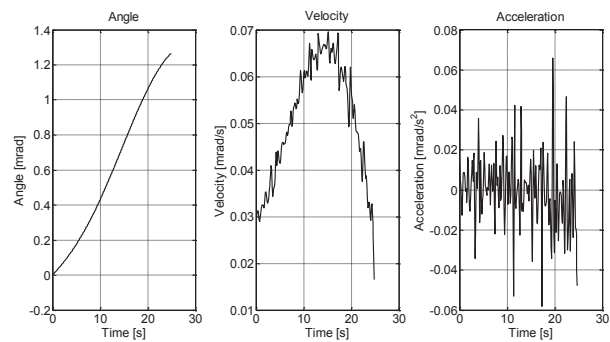

Figure 9: The results of the TS test of sample S3935.

interpretation of the results of soil stiffness degradation studies to address the above-mentioned drawbacks.

The concept proposed is based on the assumption that the intact soil structure undergoes the most important degradation changes in the first phase of applying a cyclic load (the first quarter of the hysteresis loop – see Figure 8), which can be successfully recorded in detail during the TS test conducted at very low torque rates (e.g. 0.01 Hz, see Figure 9) and a high frequency of recording measured physical quantities (e.g. 100 Hz).

Analysing the differential equation describing the TS-based research [19]:

$$I_0 \ddot{\Theta} + C \dot{\Theta} + K\Theta = T_0 \sin(\omega t) \quad (11)$$

where: I_0 – moment of inertia of the drive system, C – viscous damping constant (in a sample), K – shear stiffness modulus, T_0 – amplitude of torque, Θ – the angle of shear (the dots above the symbol indicate the derivatives of angle by time), ω – circular frequency of the given load and t – load time.

At very low frequencies ω , the influence of inertia and viscosity might be omitted, and the equation might be simplified as follows:

$$K\Theta(\tau) = T_0 \sin(\omega\tau) = T(\tau) \quad (12)$$

from which the K modulus might be determined:

$$K = \frac{T(t)}{\Theta(t)} \quad (13)$$

Having a registered dependence of the shearing angle Θ on the value of the torque T , it can be easy to determine the secant and tangent values $K(t)$ – the local inclination angles of the secant and tangent lines – using the n -point linear approximation. Having the K values determined in this way, the G moduli are calculated from the following relation:

$$G = K \frac{H}{J} \quad (14)$$

where: H – height of tested sample, J – moment of inertia of the sample cross-section.

Certainly, when the application controlling the device has built-in procedures for converting measurable physical quantities into the value of the shear strain γ and stress tangent component τ , it is more convenient to determine the G values from the direct relationship:

$$G_i = \frac{\tau_i}{\gamma_i} \text{ (secant)} \quad (15)$$

$$G_i = \frac{\Delta\tau_i}{\Delta\gamma_i} \text{ (tangent)} \quad (16)$$

Despite the simplicity of the formulation, practical determination of the local inclination of the secant and tangent lines to the relationship $\tau(\gamma)$ is accompanied by the problem of unavoidable disturbances, which effectively blur the image of stiffness degradation of the material being tested. Figure 10 shows an example of the obtained variations of the G modulus values by means of the relations (15) and (16) from the first quarter of the first load–unload cycle of the sample S3057 – three- and five-point local linear approximations for the tangent values of G were used, among others. Despite the repeated use of the technique of cleaning of measurement data by the method of ‘moving average filter’, it is difficult to distinguish a clear form of the stiffness degradation function. The authors propose the use of specialised data-clustering algorithms, such as a model-less classification system based on equations derived from quantum mechanics [20]. Approximation with formulas (4) or (10) of useful

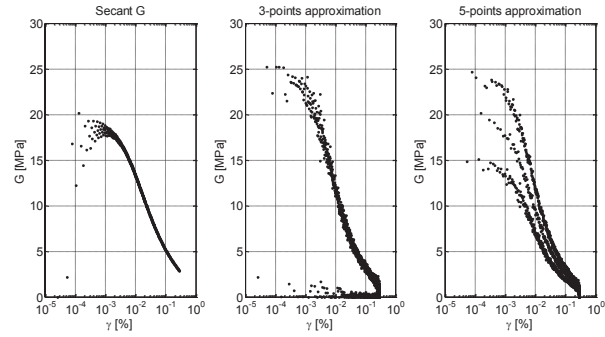

Figure 10: Results of TS analysis – sample S3057.

data separated by classifiers allows to effectively estimate the process of stiffness degradation of the tested material.

Another suggestion of an alternative method of interpreting the results of TS tests is the back analysis of the $\tau(\gamma)$ relation in the first quarter of the hysteresis loop. This method finds particular application in the process of calibration of constitutive laws implemented in Finite Element Method based calculation applications. The authors have their own application that works with the MatLab system and enables automated search for explicit and discrete $G(\gamma)$ relations by back analysis. The process of minimising the assumed objective function, which is the quadratic norm of differences between the $\tau(\gamma)$ relationships obtained from research and calculations, is managed by the algorithm developed by Nelder and Mead [21], which is available in the MatLab system. Figure 11 presents an example discretisation of a sample with TH10G15 elements (a tetrahedron with 10 nodes and 15 Gaussian integration points). In Figure 12, exemplary results of the back analysis of sample S3057 are presented (application of 600 iterations was sufficient to achieve a satisfactorily low value of the objective function). The full algorithm of the applied back analysis and MES application can be found in the study by Srokosz et al. [19].

All of the samples listed in Table 2 were analysed by the methods proposed in this study and compared with the results obtained from the RC test, and a graphical summary of the analysis results is shown in Figures 13–15. As can be seen in all cases, the results obtained from the RC tests best correspond to the form of the stiffness degradation function determined by back analysis. Significant scattering of RC results in the case of the S3935 sample is also reflected in an unusual order of degradation curves obtained from back analysis and approximation–classification analysis of the secant G values. It should be noted that although degradation functions depend on isotropic stress, this effect was not repeatedly observable

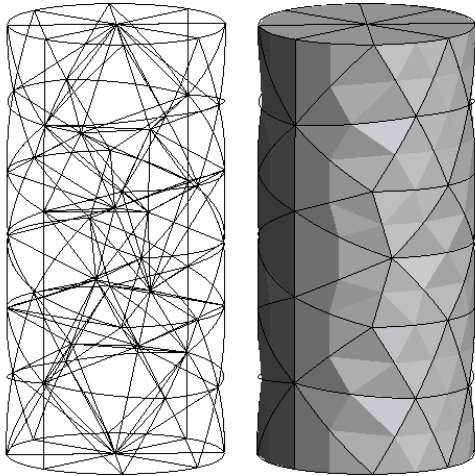

Figure 11: Exemplary discretisation of sample S3057.

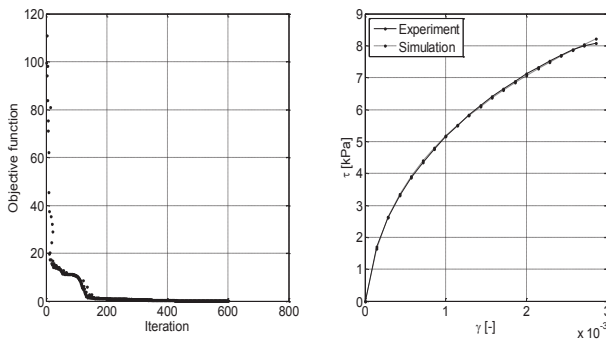

Figure 12: Exemplary results of back analysis of sample S3057.

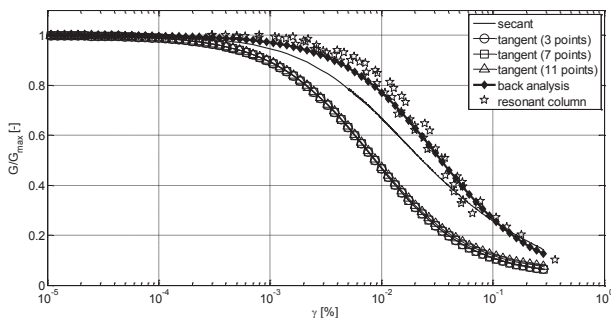

Figure 13: The results of RC/TS analyses of the sample S3057.

in research on the soil samples. On the other hand, analysing the influence of the number of selected points in the approximation and classification method, it should be stated that it is of little importance – in the majority of cases analysed herein, a 5- to 11-point approximation was successfully used.

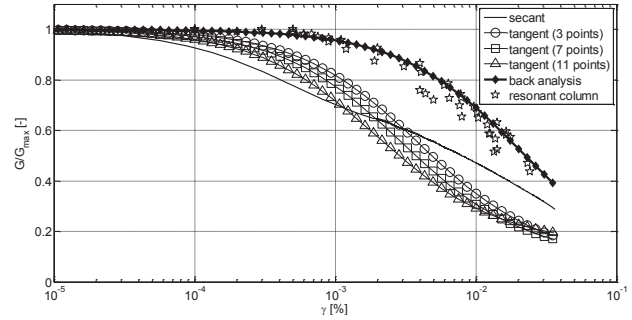

Figure 14: The results of RC/TS analyses of the sample S5919.

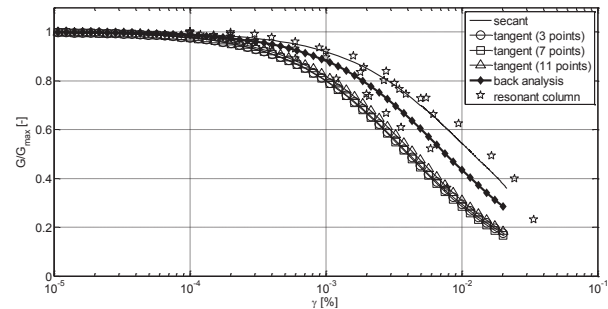

Figure 15: The results of RC/TS analyses of the sample S3935.

5 Summary and Conclusions

The alternative methods of interpretation of soil stiffness degradation tests presented in this work can be successfully used in practical issues. Certainly, performing a fragmentary TS test, providing information only about the first quarter of the hysteresis loop, is sufficient to estimate the full process of the stiffness degradation function of the tested soil (provided the sample has a sufficiently large final angle of shearing) and significantly shortens the time of the test itself. This avoids the problematic, repeated deformation of the sample, which certainly affects the quality of the obtained image of the mechanical characteristics of the material being tested. Particularly noteworthy is the back analysis method based on optimised simulations of the TS research. In the monographs of Srokosz et al. [19], a modification of this method can be found, which consists in analysing the full load–unload cycle and determining four processes of the stiffness degradation function on this basis. The authors plan to modify their apparatus to allow long-term observation of visco-plastic soil deformations in the TS test after the impact of the torque moment has ceased. Work in this direction is in progress.

References

- [1] Benz, T. (2007). Small strain stiffness of soils and its numerical consequences. Ph.D. Dissertation. Universitat Stttgart.
- [2] Truty, A. (2008). Sztywność gruntów w zakresie małych odkształceń. Aspekty modelowania numerycznego. *Czasopismo Techniczne*, 3, 107-126.
- [3] Santos, J.A., Correia, A.G. (2001). Reference threshold shear strain of soil. Its application to obtain a unique strain-dependent shear modulus curve for soil. In: *Proceedings of 15th ICSMGE*, Istanbul, Turkey, August 27-31, 2001, Vol. 1, AA Balkema, Rotterdam, pp. 267-270.
- [4] Lo Presti, D.C.F. (1991). Discussion on "threshold strain in soil". In: *Proceedings of 10th ECSMFE*, Firenze, Italy, pp. 1282-1283.
- [5] Vucetic, M. (1994). Cyclic threshold shear strains in soils. *Journal of Geotechnical Engineering*, 120(12), 2208-2228.
- [6] Tabata, K., Vucetic, M. (2010). Threshold shear strain for cyclic degradation of three clays. In: *5th International Conferences on Recent Advances in Geotechnical Earthquake Engineering and Soil Dynamics*, San Diego, CA, USA. On CD-ROM, Session 1a, Paper No. 1.15a, 12 p.
- [7] Dyka, I. (2011). Use of the laboratory tests of soil modulus in modeling of pile behavior. *Studia Geotechnica et Mechanica*, 34, 53-61.
- [8] Wichtmann, T., Triantafyllidis, T. (2010). On the influence of the grain size distribution curve on dynamic properties of quartz sand. In: *Proceedings of 5th International Conference on Recent Advances in Geotechnical Earthquake Engineering and Soil Dynamics*, Paper No. 1.55a, May 24-29, 2010, San Diego, CA, USA.
- [9] Mayne, P.W., Coop, M.R., Springman, S.M., Huang, A.B., Zornberg, J.G. (2009). Geomaterial behavior and testing. In: *Proceedings of 17th ICSMGE*, Alexandria, Egypt, pp. 2777-2872.
- [10] Duncan, J.M., Chang, C.Y. (1970). Non-linear analysis of stress and strain in soils. *Journal of Geotechnical Engineering (ASCE)*, 96(5), 1629-1653.
- [11] Hardin, B.O., Drnevich, V.P. (1972). Shear modulus and damping in soils: design equations and curves. *Journal of the Soil Mechanics and Foundations Division (ASCE)*, 98(SM7), 667-691.
- [12] Kraft, L.M., Ray, R.P., Kagawa, T. (1981). Theoretical t-z curves. *Journal of the Geotechnical Engineering Division (ASCE)*, 107(GT11), 1543-1561.
- [13] Fahey, M., Carter, J.P. (1993). A finite element study of the pressuremeter test in sand using nonlinear elastic plastic model. *Canadian Geotechnical Journal*, 30, 348-362.
- [14] Kuwabara, F. (1991). Settlement behavior of non-linear soil around single piles subjected to vertical loads. *Soils and Foundations*, 31(1), 39-46.
- [15] Van Impe, W.F., De Clercq, Y. (1994). A piled raft interaction model. In: *Proceedings of the 5th International Conference and Exhibition on Piling and Deep Foundations – DFI'94*, Bruges, Belgium, pp. 1.3.1-1.3.10.
- [16] Darendeli, M.B. (2001). Development of a new family of normalized modulus reduction and material damping curves. Ph.D. Thesis. The University of Texas at Austin, USA.
- [17] Vardanega, P.J., Bolton, M.D. (2011). Practical methods to estimate the non-linear shear stiffness of clays and silts. In: *Proceedings of 5th International Conference on the Deformation Characteristics of Geomaterials*, Seoul, Korea, September 1-3, 2011, IOS Press, Amsterdam, Netherlands, pp. 372-379.
- [18] Vardanega, P.J., Bolton, M. (2013). Stiffness of clays and silts: normalizing shear modulus and shear strain. *Journal of Geotechnical and Geoenvironmental Engineering, ASCE*, 139, 1575–1589.
- [19] Srokosz, P., Dyka, I., Bujko, M. (2017). Badania sztywności gruntu w kolumnie rezonansowej. Monograph, Wydawnictwo UWM w Olsztynie.
- [20] Srokosz, P., Bujko, M., Górską-Pawliczuk, A. (2015). Zastosowanie systemu klasyfikacyjnego do interpretacji wyników badań skrętnego ścinania gruntów. *Inżynieria Morska i Geotechnika*, 5, 686-692.
- [21] Nelder, J.A., Mead, R. (1965). A simplex method for function minimization. *Computer Journal*, 7(4), 308-313.